

iMeter 7A

Advanced Power Quality Analyzer

User Manual

Version: V1.3

March 20, 2026

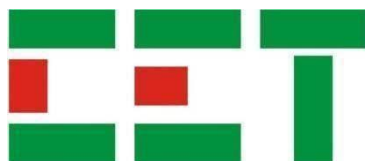

This manual may not be reproduced in whole or in part by any means without the express written permission from CET Electric Technology (CET).

The information contained in this Manual is believed to be accurate at the time of publication; however, CET assumes no responsibility for any errors which may appear here and reserves the right to make changes without notice. Please consult CET or your local representative for latest product specifications.

Standards Compliance



DANGER

This symbol indicates the presence of danger that may result in severe injury or death and permanent equipment damage if proper precautions are not taken during the installation, operation or maintenance of the device.



CAUTION

This symbol indicates the potential of personal injury or equipment damage if proper precautions are not taken during the installation, operation or maintenance of the device.



Failure to observe the following instructions may result in severe injury or death and/or equipment damage.

- Installation, operation and maintenance of the meter should only be performed by qualified, competent personnel that have the appropriate training and experience with high voltage and current devices. The meter must be installed in accordance with all local and national electrical codes.
- Ensure that all incoming AC power and other power sources are turned OFF before performing any work on the meter.
- Before connecting the meter to the power source, check the label on top of the meter to ensure that it is equipped with the appropriate power supply, and the correct voltage and current input specifications for your application.
- During normal operation of the meter, hazardous voltages are present on its terminal strips and throughout the connected potential transformers (PT) and current transformers (CT). PT and CT secondary circuits are capable of generating lethal voltages and currents with their primary circuits energized. Follow standard safety precautions while performing any installation or service work (i.e. removing PT fuses, shorting CT secondaries, ...etc).
- Do not use the meter for primary protection functions where failure of the device can cause fire, injury or death. The meter should only be used for shadow protection if needed.
- Under no circumstances should the meter be connected to a power source if it is damaged.
- To prevent potential fire or shock hazard, do not expose the meter to rain or moisture.
- Setup procedures must be performed only by qualified personnel familiar with the instrument and its associated electrical equipment.
- DO NOT open the instrument under any circumstances.

Limited warranty

- CET Electric Technology (CET) offers the customer a minimum of 12-month functional warranty on the meter for faulty parts or workmanship from the date of dispatch from the distributor. This warranty is on a return to factory for repair basis.
- CET does not accept liability for any damage caused by meter malfunctions. CET accepts no responsibility for the suitability of the meter to the application for which it was purchased.
- Failure to install, set up or operate the meter according to the instructions herein will void the warranty.
- Only CET's duly authorized representative may open your meter. The unit should only be opened in a fully anti-static environment. Failure to do so may damage the electronic components and will void the warranty.

Table of Contents

Chapter 1 Introduction	1
1.1 Overview	1
1.2 Features	1
1.3 iMeter 7A's application in Power Quality Monitoring and Energy Management Systems	6
1.4 Getting more information	6
Chapter 2 Installation	7
2.1 Appearance	7
2.2 Unit Dimension	7
2.3 Terminal Dimension	8
2.4 Mounting	8
2.5 Wiring Connections	9
2.5.1 3-Phase 4-Wire Wye Direct Connection with 4CTs	9
2.5.2 3-Phase 4-Wire Wye with 3PTs and 4CTs	10
2.5.3 3-Phase 3-Wire Grounded Wye with no PTs & 3CTs	10
2.5.4 3-Phase 3-Wire Grounded Wye with 3PTs & 3CTs	11
2.5.5 3-Phase 3-Wire Delta Direct Connection with 3CTs	11
2.5.6 3-Phase 3-Wire Open Delta with 2PTs & 3CTs	12
2.5.7 3-Phase 3-Wire Open Delta with 2PTs & 2CTs	12
2.6 Communications Wiring	12
2.6.1 Ethernet Port (10/100BaseT)	12
2.6.2 RS-485 Port	13
2.7 Chassis Ground Wiring	13
2.8 Digital Input Wiring	13
2.9 GPS 1PPS Input wiring	13
2.10 Digital Output Wiring	13
2.11 Alarm Output Wiring	14
2.12 RTD Input Wiring	14
2.13 Pulse Output Wiring	14
2.14 Analog Input Wiring	14
2.15 Power Supply Wiring	14
Chapter 3 User Interface	15
3.1 Front Panel Interface	15
3.1.1 LED Indicator	15
3.1.2 Front Panel Button	15
3.1.3 Front Panel Display	16
3.2 On-board Web Interface	30
3.2.1 Setting PC's IP Address	30
3.2.2 Configure iMeter 7A's IP Address	31
3.2.3 Accessing Web Interface	31
Chapter 4 Applications	92
4.1 Inputs and Outputs	92
4.1.1 Digital Input	92
4.1.2 Digital Output	93
4.1.3 Energy Pulse Output (Optional)	94
4.1.4 Analog Input (Optional)	94
4.1.5 RTD Input (Optional)	94
4.2 Power, Energy and Demand	95
4.2.1 Basic Measurements	95
4.2.2 High-Speed Measurements	95
4.2.3 Energy Measurements	95
4.2.4 Demand Measurements	96
4.3 Power Quality Parameters	98
4.3.1 Power Frequency and Freq. Deviation	98
4.3.2 Magnitude of the Supply Voltage	98
4.3.3 Magnitude of Current	98
4.3.4 Flicker	98

4.3.5 PQ Disturbance – Dip/Swell/Interruption	99
4.3.6 Transient Voltage	103
4.3.7 Phase Angle.....	104
4.3.8 Supply Voltage and Current Unbalance	104
4.3.9 Harmonic and Interharmonic.....	104
4.3.10 K-Factor	108
4.3.11 Crest Factor	108
4.3.12 MSV (Mains Signalling Voltage)	108
4.3.13 RVC (Rapid Voltage Change)	108
4.3.14 Underdeviation and Overdeviation.....	109
4.3.15 Flagging Concept.....	110
4.3.16 Conducted Emissions in the 2kHz to 150kHz range	111
4.3.17 Inrush Current.....	112
4.3.18 EN 50160 Compliance Report	113
4.3.19 ITIC/SEMI F47 Plot and Alarm	114
4.3.20 IEEE Std 519-2022 Compliance Report	116
4.4 Motor Start Monitoring	120
4.4.1 Motor State.....	120
4.4.2 Motor Start Monitoring	120
4.5 Setpoint.....	121
4.6 Data Logging	123
4.6.1 IER/AER	123
4.6.2 WFR (Waveform Recorder)	123
4.6.3 DWR (Disturbance Waveform Recorder)	125
4.6.4 RMSR (RMS Recorder)	126
4.6.5 Pst Log.....	126
4.6.6 Plt Log	126
4.6.7 SDR (Statistical Data Recorder)	126
4.6.8 DR (Data Recorder)	127
4.6.9 Max./Min. Recorder	127
4.6.10 SOE Log & Device Log	128
4.6.11 PQ Counters	128
4.7 iTrigger	129
4.8 Time of Use (TOU).....	130
4.9 Time Synchronization.....	131
4.9.1 RTC	131
4.9.2 GPS.....	131
4.9.3 IRIG-B	131
4.9.4 IEEE 1588 (PTP)	131
4.9.5 NTP.....	132
4.9.6 Modbus RTU/TCP.....	132
4.9.7 PecStar iEMS	132
4.10 Alarm Email (SMTP)	133
4.11 Ethernet Gateway	137
4.12 SNMP	139
4.12.1 Overview.....	139
4.12.2 Using SNMP	139
4.13 On-board FTPS Server	143
4.13.1 Access the FTPS Server	143
4.13.2 Quick Overview for FTPS Files.....	145
4.14 IPsec VPN	147
4.15 Cloud.....	149
Chapter 5 Modbus Map	150
5.1 Function Code and Data Format	150
5.1.1 03 (0x03) Read Holding Registers	150
5.1.2 05 (0x05) Force Single Coil.....	150
5.1.3 16 (0x10) Write Multiple Registers	151

5.2 Register Format.....	151
5.3 Data Encoding	151
5.4 Basic Measurement	151
5.5 High-Speed Measurement	154
5.6 3-Phase Total Energy Measurement (INT64)	154
5.7 3-phase Total Energy Measurement (INT32)	155
5.8 Per-phase Energy Measurements (INT64)	155
5.9 Per-phase Energy Measurements (INT32)	156
5.10 DI Pulse Counter	157
5.11 PQ Measurement.....	157
5.12 Harmonic & Interharmonic Measurement	159
5.12.1 Harmonic Distortion.....	159
5.12.2 Harmonic RMS Measurement.....	160
5.12.3 Individual Total Harmonic Power	161
5.12.4 Harmonic Power	161
5.12.5 Harmonic Angle	162
5.12.6 Harmonic Energy (INT64).....	162
5.12.7 Harmonic Energy (INT32).....	163
5.12.8 Interharmonic Distortion Measurement.....	164
5.12.9 Interharmonic RMS Measurement	165
5.13 Demand	166
5.13.1 Present Demand	166
5.13.2 Predicted Demand	168
5.13.3 Max. Value per Demand Period	169
5.13.4 Min. Value per Demand Period.....	171
5.13.5 This/Last Max. Demand Log.....	173
5.14 Real-time IER and AER	173
5.14.1 Real-time 3-phase Total IER and AER (INT64)	173
5.14.2 Real-time 3-phase Total IER and AER (INT32)	173
5.14.3 Real-time Per-phase IER and AER (INT64).....	174
5.14.4 Real-time Per-phase IER and AER (INT32).....	175
5.15 2kHz – 150kHz C.E. Real-time Measurement.....	176
5.16 Data Logging	177
5.16.1 Device Log Buffer	177
5.16.2 SOE Log Buffer	177
5.16.3 Latest PQD Log.....	178
5.16.4 Statistical Data Recorder.....	179
5.16.5 DR (Data Recorder) Log.....	180
5.16.6 Max./Min. Log.....	181
5.16.7 Pst/Plt Log.....	182
5.16.8 IER & AER Log.....	183
5.16.9 IEEE Std 519-2022 Report	186
5.16.10 TOU Log.....	188
5.17 Device Setting	190
5.17.1 iTrigger Setting	190
5.17.2 VPN Setting	190
5.17.3 Communication Setting	191
5.17.4 DI Setting.....	191
5.17.5 DO Setting	192
5.17.6 AI Setting.....	192
5.17.7 Cloud Setting.....	192
5.17.8 Algorithm Setting	193
5.17.9 Other Setting.....	194
5.17.10 SMTP Setting.....	196
5.17.11 Basic Setting.....	197
5.17.12 PQ Setting	198
5.17.13 Demand Setting	199

5.17.14 WFR Setting	199
5.17.15 Energy Pulse Setting.....	200
5.17.16 Setpoint Setting	201
5.17.17 SDR Setting.....	202
5.17.18 DR Setting	205
5.17.19 Max./Min. Recorder Setting.....	207
5.17.20 EN 50160 Setting.....	209
5.17.21 TOU Setting	210
5.17.22 IEEE Std 519-2022 Report Setting	213
5.18 Control Operation	214
5.18.1 Alarm/DO Control	214
5.18.2 Clear/Manual Trigger Operation	215
5.19 Time Register	216
5.20 Information	217
5.20.1 Substation Information	217
5.20.2 Site Information	217
5.20.3 Device Information	217
5.20.4 Communication Status.....	218
Appendix A – Source Parameters for SDR, DR and Max./Min. Recorders.....	219
Appendix B – Device Log Classification.....	225
Appendix C – SOE Log Classification	227
Appendix D – Technical Specification	229
Appendix E – Accuracy Specification	231
Appendix F – Standard Compliance	232
Appendix G – Ordering Guide.....	233
Contact us	234

Chapter 1 Introduction

This manual explains how to use the iMeter 7A Advanced Power Quality Analyzer. Throughout the manual, the term “meter” generally refers to all models.

This chapter provides an overview of the iMeter 7A and summarizes many of its key features.

1.1 Overview

The iMeter 7A is one of CET’s latest Advanced PQ Analyzer designed for the compliance monitoring market as it offers unsurpassed functionality by combining Class 0.2S Accuracy and advanced PQ Features in a compact DIN 144 form factor with a stunning, high resolution, color TFT LCD display. The iMeter 7A complies with such standards as IEC 62053-22 Class 0.2S, IEC 61000-4-30 Edition 3.1 Class A, IEC 61000-4-15, IEC 61000-4-7, EN 50160-2022, IEEE Std 519-2022 and IEC 61850 for Substation Automation. Further, the iMeter 7A offers 4GB on-board memory, extensive I/O with 4xDI, and 3xDO, as well as optional 2xSS Pulse Output, 2xAI or 2xRTD, multiple Time Sync. methods, dual 10Base-T/100Base-TX Ethernet and one RS-485 ports. These features likely make the iMeter 7A one of the most Advanced PQ Analyzers for an intelligent Power Quality Monitoring System.

Following is a list of typical applications for the iMeter 7A:

- PQ monitoring at HV, MV and LV Utility Substations
- Data Centers, Semiconductor Fabs, Heavy Industries, Renewable Energy Applications
- 7x24 Automated Manufacturing Facilities
- Mains and Critical feeder monitoring
- Dips/Swells/Interruptions, Transients, Flickers & Harmonics Monitoring
- IEC 61850 support for Substation Automation and Smart Grid
- Retrofit applications with optional Class 0.5S Split-Core Current Probes

Contact CET Technical Support should you require further assistance with your application.

1.2 Features

Basic Features

- IEC 62053-22 Class 0.2S kWh metering with Multi-Tariff TOU
- True RMS @ 1024 samples/cycle sampling
- 4GB on-board log memory
- Industrial-grade, 5” high-resolution Color TFT LCD @ 800x480
- Device Operating Time (Running Hours)
- Time Sync. via IRIG-B, NTP, IEEE 1588 (PTP) or GPS 1PPS output
- 64 Programmable Setpoints
- Dual 10Base-T/100Base-TX Ethernet and one RS-485 ports

Power Quality Features

- IEC 61000-4-30 Ed. 3.1 Class A Certified
- EN 50160-2022 and IEEE Std 519-2022 Reporting
- 2kHz to 150kHz Conducted Emission Measurements
- Dips, Swells, Interruptions, Transients, Rapid Voltage Changes, Inrush Current, Mains Voltage Signalling, Flicker monitoring
- Real-time Waveform Capture (WFC), Waveform Recording (WFR) & Disturbance Waveform Recording (DWR) in COMTRADE format
- Disturbance Direction Indicator for Dips, Swells and Interruptions
- Statistical Data Recording and ½ cycle RMS Recording

Front Panel Display and Web Interface

- True RMS Real-time, Harmonics, Power and Energy measurements
- Phasor Diagram
- Demands and Multi-Tariff TOU
- Max. & Min. Logs
- Deviation, Sequence & Unbalance
- Real-time WFC of 3-phase U & I @ 128 samples/cycle
- Event Waveforms, RMS Recording and ITIC/SEMI F47 Curves
- Harmonics & Interharmonics Histogram
- Device and SOE Logs, PQ Counters and I/O Status
- Device Configuration and Diagnostics
- Remote access to Front Panel display via Web Interface

Power Quality Metering

PQ Parameters as per IEC 61000-4-30 Ed. 3.1 Class A Certified

- Power Frequency
- Magnitude of the Supply Voltage
- Flicker
- Supply Voltage Interruptions, Dips and Swells
- Supply Voltage Unbalance
- Voltage Harmonics and Interharmonics
- Mains Signalling Voltage on the Supply Voltage
- Rapid Voltage Changes
- Measurement of Over Deviation and Under Deviation Parameters
- Magnitude of Current
- Current Harmonics and Interharmonics
- Current Unbalance
- 2kHz to 150kHz Conducted Emission Measurements

Harmonic and Interharmonic Measurements

- K-Factor for Current, Crest Factor for Current and Voltage
- U and I THD, TOHD, TEHD, TIHD, TEIHD, TOIHD and TH (RMS)
- U and I Individual Harmonics (%HD, RMS and Angle) from 2nd to 63rd#
- U and I Individual Interharmonics (%IHD and RMS) from 1st to 63rd#
- Total Harmonic P, Q, S and PF
- Harmonic P, Q, S and PF from 2nd to 63rd in RMS
- Fundamental U, I, P, Q, S, Phase Angle and Displacement PF
- Harmonic Phase Angle from 2nd to 63rd
- U and I DC Components

#%HD and %IHD can be configured as % of Fundamental, % of U/I nominal or % of RMS

Conducted Emissions in the 2kHz to 150kHz Range

- Real-time amplitude (150/180-cycle) and the Max., Min., Avg. and 95th percentile values (in 1-min interval) for Voltage channels with a total of 106 frequency segments (2kHz-150kHz range) and Current channels with a total of 35 frequency segments (2kHz-9kHz range)
- Daily Heat Map display on the Web Interface for the Max., Min., Avg. and CP95 values

Sequence and Unbalances

- Zero, Positive and Negative Sequence Components
- U and I Unbalance based on Zero and Negative Sequence Components

Dip, Swell, Interruption Recording

- Dip, Swell, Interruption detection @ 10ms (½ cycle at 50 Hz)
- Trigger for DO, SOE, DR, WFR, DWR, RMSR, iTrigger and Alarm Email
- Configurable DO triggered for the Start or End of a PQ disturbance
- Display of Event specific WFR, DWR and/or RMSR as well as the associated ITIC/SEMI F47 plot on the Front Panel and Web Interface
- ITIC/SEMI F47 Alarm trigger for DO and iTrigger upon the detection of PQ disturbances that are outside of the respective tolerance curves

Transient Recording

- Transients capture as short as 20us @ 50Hz or 16.67us @ 60Hz at 1024 samples for sub-cycle disturbances such as capacitor switching and resonance phenomena
- Trigger for DO, SOE, WFR, DWR, RMSR, iTrigger and Alarm Email
- Display of Event specific WFR, DWR and/or RMSR on the Front Panel and Web Interface

Rapid Voltage Changes (RVC)

- Detection of a quick transition in RMS voltage between two steady-states

Inrush Current Monitoring

- Monitoring of the ½ cycle RMS Current and capturing of the Current waveforms associated with events such as motor starting and transformer being energized

Disturbance Direction Indicator

- Determine if a PQ Disturbance Event is located upstream or downstream
- Pinpoint if the cause of the event is external or internal

PQ Event Counters

- Dips, Swells, Interruptions, Transients, Rapid Voltage Changes, Inrush Currents, Mains Signalling Voltages and Total PQ Event Counters

Metering

Basic Measurements (1-second update)

- 3-phase U, I, P, Q, S and PF as well as U4, I4, Ung, Frequency and IR

High-Speed Measurements

- 3-phase U, I, P, Q, S and PF as well as U4 and I4 @ ½ cycle
- Frequency @ 1 cycle

Energy

- Per-phase kWh, kvarh Import/Export/Net/Total and kVAh Total
- Total RMS kWh, kvarh Import/Export/Net/Total and kVAh Total
- Total Fundamental kWh, kvarh Import/Export/Net/Total
- Total Harmonic kWh, kvarh Import/Export/Net/Total
- Total Harmonic kWh, kvarh Import/Export from 2nd to 63rd

Demands

- Present and Predicted Demand for 3-phase U, I, I Fund., P, Q, S, PF as well as U4, I4, I4 Fund. and Frequency
- Present Demand for 4-phase U & I THD/TOHD/TEHD, 4-phase Current K-factor, U/I Unbalances as well as Voltage Deviations and Frequency Deviation
- Max./Min. values per Demand Interval
- Max. Demand for This Month & Last Month (or Since Last Reset & Before Last Reset)
- Demand Synchronization with DI

Multi-Tariff TOU capability

- Two independent sets of TOU Schedules
 - Up to 12 Seasons
 - 90 Holidays or Alternate Days and 3 Weekend Days
 - 20 Daily Profiles, each with 12 Periods in 15-minute intervals
 - 8 Tariffs, each providing the following information:
 - kWh/kvarh Import/Export and kVAh
 - P/Q Import/Export Max. Demands
 - Register rollover at 100,000,000,000.000 kXh
- Switching between two TOU schedules manually or according to pre-programmed time
- 12 Historical Logs for Energy and Max. Demand

Data and Event Recorders

Non-volatile Log Memory

- 4GB on-board log memory

Interval Energy Recorder (IER) and Accumulative Energy Recorder (AER)

- Both IER Log and AER Log support recording of per-phase and Total RMS kWh, kvarh Import/Export/Total/Net and kVAh Total, Total Fundamental and Total Harmonic kWh, kvarh Import/Export.
- Recording interval from 1 to 65535 minutes
- Max. Recording Depth @ 65535 records
- Support FIFO and Stop-When-Full Mode

Statistical Data Recording (SDR) Log

- 8 SDR logs of 64 parameters each
- Recording of Max., Min., Avg. and 95th percentile for real-time measurements including U, I, Freq., P, Q, S, PF, Harmonics, Deviations and Unbalances
- Recording Interval from 1 to 60 minutes
- 90 days @ 3-minute, 300 days @ 10-minute, 450 days @ 15-minute
- Downloadable via free software
- Support FIFO or Stop-When-Full Mode

Data Recorder (DR)

- 8 DR Logs of max. 64 parameters each
- RMS/Fundamental/Harmonic/Interharmonic Measurements, Demands, Deviations, Mains Signalling Voltages, Unbalances and Flicker
- Configurable Recording Offset and Interval from 1s to 40 days
- Max. Recording Depth @ 65535 records
- Support FIFO or Stop-When-Full mode

Max/Min Recorder (MMR)

- 4 Max/Min Recorders of 20 parameters each
- RMS/Fundamental/Harmonic/Interharmonic Measurements, Demands, Deviations, Mains Signalling Voltages, Unbalances and Flicker
- Two transfer modes:
 - Manual: Max./Min. Since the Last Reset & Before the Last Reset
 - Auto: Max./Min. of This Month & Last Month

SOE Log

- 1024 FIFO events time-stamped to ± 1 ms resolution
- Setpoint event, I/O operation, Dip, Swell, Interruption, Transient, Rapid Voltage Change, Inrush Current, Mains Signalling Voltage, Motor Start, iTrigger, etc.
- Record the characteristics data of Setpoint event as well as WFR, DWR, RMSR, ITIC and SEMI F47 Curve for PQ events

Device Log

- 1024 FIFO entries time-stamped to ± 1 ms resolution
- Power On/Off, Setup changes, Time Sync., Device Operations and Self-diagnostics

Real-Time Waveform and Waveform Recorder (WFR)

- Real-time WFC @ 128 samples/cycle via Front Panel and Web Interface
- WFR with max. 128 entries
- Simultaneous capture of 4-phase Voltage and Current Inputs
- (Range of Cycles) x Samples/Cycles with programmable pre-fault and post-fault cycles: (40-400)x1024, (40-800)x512, (40-1600)x256, (40-3200)x128
- Scheduled WFR with max. repetition of 10,000 times and programmable schedule from 1 to 65535 min.
- COMTRADE file format, downloadable from the on-board Web Server or FTPS Server

Disturbance Waveform Recorder

- 128 entries
- Simultaneous recording of all Voltage (U1-U4) and Current (I1-I4) Inputs
 - Initial Fault: 35 cycles @ 512 samples/cycle
 - Extended Fault: Up to 150 cycles @ 16 samples/cycle
 - Steady State: Up to 360 seconds of 1-cycle absolute peak values
 - Post Fault: 15 cycles @ 512 samples/cycle

RMS Recorder (RMSR)

- 128 entries
- 16 channels max., selectable U, I, P, Q, S, PF, Freq. Freq. Deviation
- Recording Interval from 0.5 to 60 cycles
- Recording Width @ 7200 samples per parameter
- Configurable pre-fault samples from 100 to 500
- 72 seconds of $\frac{1}{2}$ cycle RMS recording @ 50Hz or 60 seconds @ 60Hz

iTrigger

- Cross-trigger DO, SOE Log, WFR, DWR, RMSR and Alarm Email with other iMeter devices within the same Local area network (LAN)
- Provides Group ID and MAC Address as the trigger source

IEEE Std 519-2022 Report

- 365 Daily Reports for statistical evaluations on Voltage and Current Harmonics based on 99th percentile very short time (3 s) values
- 52 Weekly Reports for statistical evaluations on Voltage Harmonics (95th percentile) and Current Harmonics (95th and 99th percentile) short time (10 min) values
- Programmable settings for Report Mode, PCC Voltage, Max. Short Circuit Current, etc.

Setpoints

PQ Setpoint

- Transients, Dips, Swells, Interruptions, ITIC Alarm, SEMI F47 Alarm
- Rapid Voltage Changes, Inrush Current
- Trigger DO, DR, SOE Log, WFR, DWR, RMSR, iTrigger and Alarm Email

Motor Start Setpoint

- Monitoring motor startup procedure with the recording of Max. Starting Current, Minimum Voltage and Duration
- Trigger DO, DR, SOE Log, WFR, DWR, RMSR, iTrigger and Alarm Email

Control Setpoint

- 64 Control Setpoints can be configured with extensive monitoring sources including U, I, P, Q, S, Frequency, Demands, Harmonics, Unbalances, Deviations, Flickers, Phase Reversal/Loss, TC and AI, etc.
- Configurable thresholds and time delays
- Trigger DO, DR, SOE Log, WFR, DWR, RMSR, iTrigger and Alarm Email

Digital Input Setpoint

- Provides Control Output Actions in response to changes in DI status
- Trigger DO, DR, SOE Log, WFR, DWR, RMSR, iTrigger and Alarm Email

Inputs and Outputs

Digital Inputs

- Standard 4 and optional 8 channels, volt-free dry contact, 24VDC Internal Excitation
- 1000Hz sampling for status monitoring with programmable debounce
- Pulse counting for collecting WAGES (Water, Air, Gas, Electricity, Steam) information
- Demand Synchronization and Tariff Switching based on DI Status

Digital Outputs

- Standard 2 or optional 4 channels Form A Mechanical Relays for general-purpose control or alarming
- Optional 2 Solid State Relays for Energy pulsing applications
- 1 Normally Closed Mechanical Relay for LOP Alarming

Analog Inputs (Optional)

- Optional 2xAI, 0/4-20mA DC input with programmable zero and full scales that can be used to measure external transducer signal
- Optional 2xRTD for Temperature Measurements (PT100 sensor not included)

Communications

Ethernet Port (P1, P2)

- Dual 10Base-T/100Base-TX Ethernet Ports with RJ45 connector
- Selectable IP Addressing Mode – DHCP and Static
- White List for Client Access Control
- Protocol supported: Modbus TCP, HTTPS, NTP, SMTPS, SNMP, FTPS, MQTT, IPsecVPN, RSTP~ and IEC 61850
- Built-in password-protected Web Server with multiple user accounts and pre-defined roles for easy data viewing, firmware upgrade and setup configuration
- Simultaneous client connections for 12xModbus TCP and 4xIEC 61850

~ Available in Firmware V2.50.08 or later

RS-485 (P3)

- One optically isolated RS-485 port with a baud rate from 1.2 to 38.4 kbps
- Support Modbus RTU and Ethernet Gateway

Time Synchronization

- Battery-backed real-time clock @ 6ppm ($\leq 0.5s/day$)
- Time Sync. with auto-selection among Modbus RTU/TCP, NTP, GPS 1PPS, IRIG-B and IEEE 1588 (PTP)

System Integration

PecStar® iEMS

- The iMeter 7A is supported by CET's PecStar® iEMS
- In addition, the iMeter 7A can be easily integrated into other 3rd party systems because of its support of multiple communications ports and different industry-standard protocols such as Modbus and IEC 61850

iPQ Explore

- Compact, password protected free software for simultaneous connection with multiple iMeter series Analyzers
- Support configurations for all setup parameters
- Display of Real-time measurements, PQ Events and Waveforms
- Export of IER, AER, DR and SDR Logs as well as EN 50160-2022 and IEEE Std 519-2022 Reports

3rd Party System Integration

- Easy integration into Substation Automation or Utility SCADA systems via Modbus RTU/TCP or IEC 61850
- The on-board, password-protected Web Server provides user-friendly access to its data and supports the configuration for most Setup parameters via a web browser without the use of proprietary software.
- The on-board, password-protected FTPS Server allows the Excel files for the logged C.E. Measurement data, IEEE Std 519-2022 Daily and Weekly reports and the COMTRADE files for the waveform records to be downloaded without any special software. The downloaded files can be subsequently viewed using software that supports these industry-standard file formats.

1.3 iMeter 7A's application in Power Quality Monitoring and Energy Management Systems

The iMeter 7A can be used to monitor the 3P4W or 3P3W connected power system. Modbus communications allow Real-time data, Events, DI status, DR Logs, Waveform and other information to be transmitted to an Integrated Energy Management System such as PecStar® iEMS.

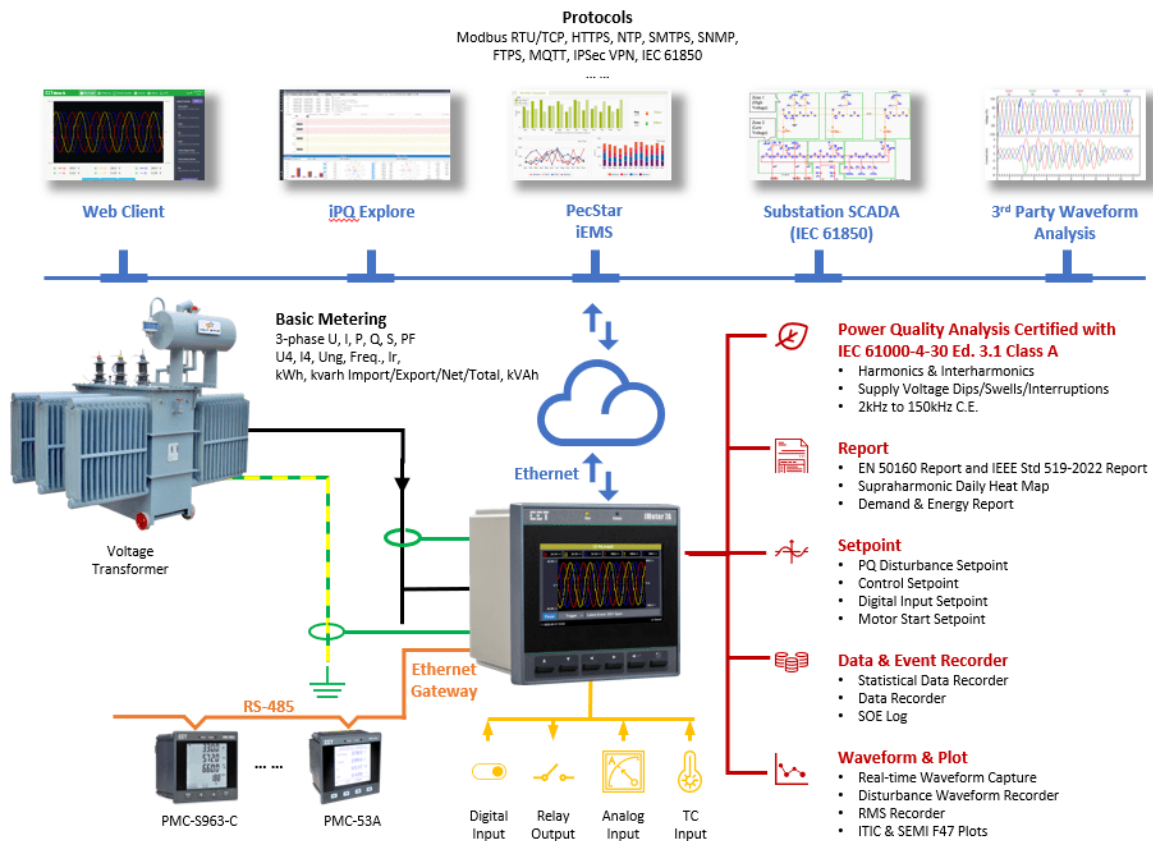

Figure 1-1 Typical Application

1.4 Getting more information

Additional information is available from CET via the following sources:

- Visit www.cet-global.com
- Contact your local representative

Contact CET directly via email at support@cet-global.com

Chapter 2 Installation



Caution

Installation of the iMeter 7A should only be performed by qualified, competent personnel that have the appropriate training and experience with high voltage and current devices. The meter must be installed in accordance with all local and national electrical codes.

During the operation of the meter, hazardous voltages are present at the input terminals. Failure to observe precautions can result in serious or even fatal injury and equipment damage.

2.1 Appearance

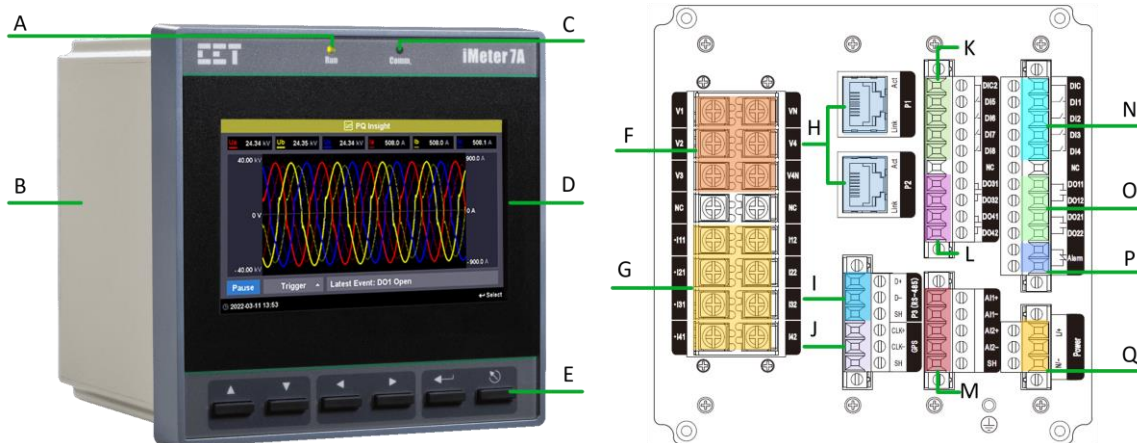

A	Running Indicator	G	Current Inputs	M#	Analog Inputs*/RTD Inputs*
B	Enclosure	H	10Base-T/100Base-TX Ethernet Ports	N	Digital Inputs
C	Communication Indicator	I	RS-485 Port	O#	Digital Outputs / SS Pulse Outputs*
D	TFT Color LCD Display	J	GPS Input	P	Alarm Output
E	Navigation Buttons	K	Digital Inputs*	Q	Power Supply
F	Voltage Inputs	L	Digital Outputs*		

* Optional.

The Analog Inputs may be optionally replaced by RTD Inputs. Two standard Digital Outputs may be optionally replaced by SS Pulse Outputs.

Figure 2-1 Appearance

2.2 Unit Dimension

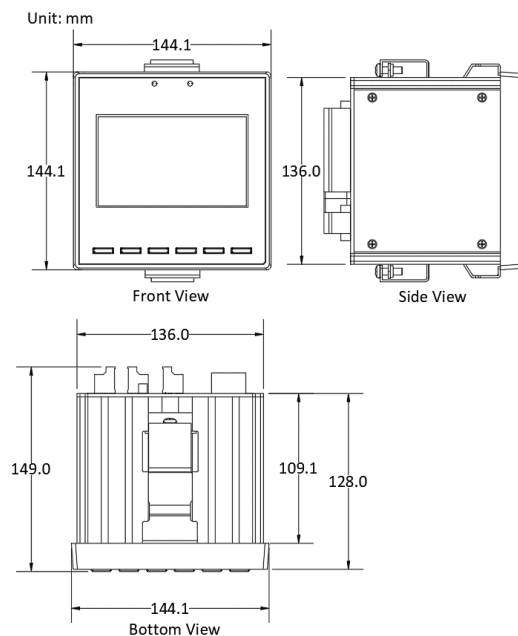
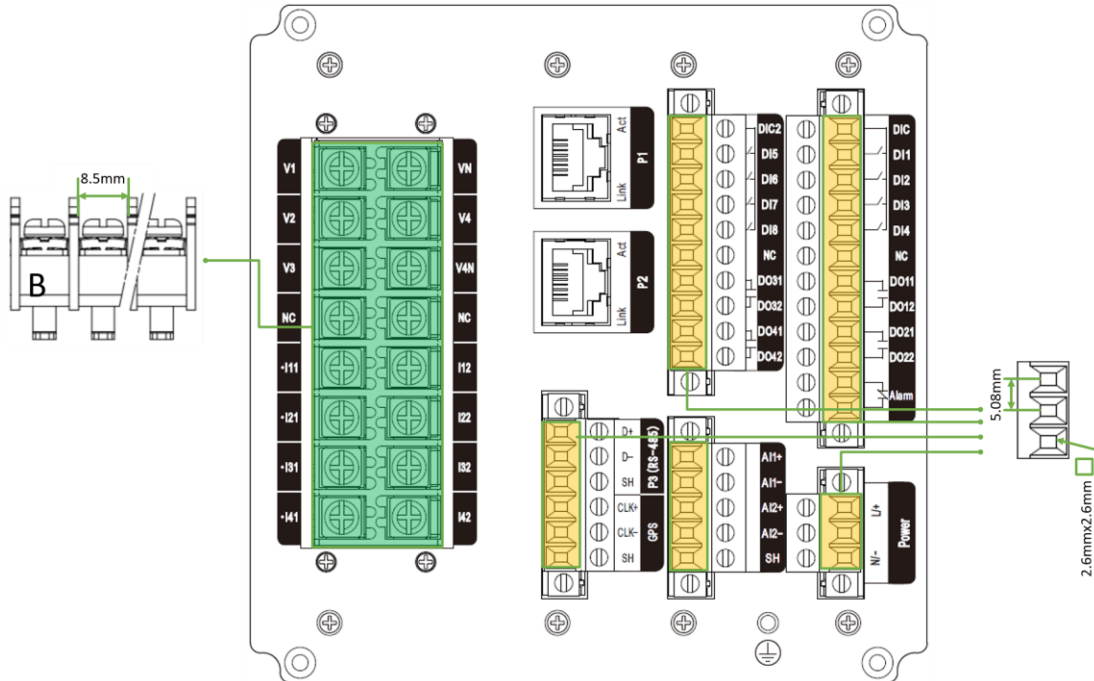

Figure 2-2 Unit Dimension

2.3 Terminal Dimension



No.	Terminal	Recommended Wire Size	Torque
1	Voltage Input	0.2 - 5.0mm ²	Tightening: 1N·m/10kgf.cm/8.85lb-in/M4 Max.: 3.6N·m/36.7kgf.cm/31.8lb-in/M4
	Current Input	10 - 24AWG	
2	Power Supply	0.2 - 3.5mm ² 12 - 26AWG	Tightening: 0.25N·m/2.5kgf.cm/2.21lb-in/M2.5 Max.: 0.39N·m/4kgf.cm/3.47lb-in/M2.5
	DI/Alarm/DO		
	AI		
	GPS/RS-485		

Table 2-1 Terminal Dimension

2.4 Mounting

The iMeter 7A should be installed in a dry environment with no dust and kept away from heat, radiation and electrical noise sources.

Installation steps:

- Remove the mounting slide bars from the meter
- Fit the meter through a 138mm x 138mm cutout as shown in **Figure 2-3**
- Re-install the mounting slide bars and tighten the screws against the panel to secure the meter

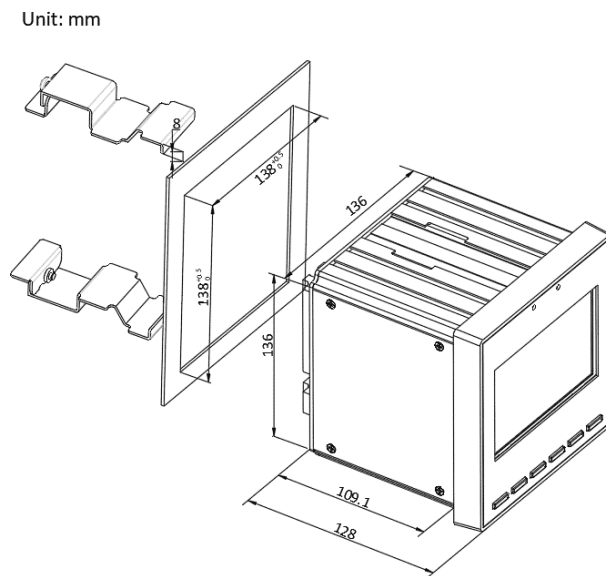

Figure 2-3 Installation

2.5 Wiring Connections

iMeter 7A can satisfy almost any three or four-phase power system. Please read this section carefully before installation and choose the correct wiring method for your power system. The following wiring modes are supported:

- 3-Phase 4-Wire Wye Direct Connection with 4CTs
- 3-Phase 4-Wire Wye with 3PTs and 4CTs
- 3-Phase 3-Wire Grounded Wye with no PTs & 3CTs
- 3-Phase 3-Wire Grounded Wye with 3PTs and 3CTs
- 3-Phase 3-Wire Direct Delta Connection with 3CTs
- 3-Phase 3-Wire Open Delta with 2PTs and 3CTs
- 3-Phase 3-Wire Open Delta with 2PTs and 2CTs



Caution

Under no circumstances should the PT secondary be shorted.

Under no circumstances should the CT secondary be open when the CT primary is energized. CT shorting blocks should be installed to allow for easy maintenance.

2.5.1 3-Phase 4-Wire Wye Direct Connection with 4CTs

Please consult the serial number label to ensure that the system phase voltage is less than or equal to the device's voltage input specification. Set the **Wiring Mode** to 3P4W.

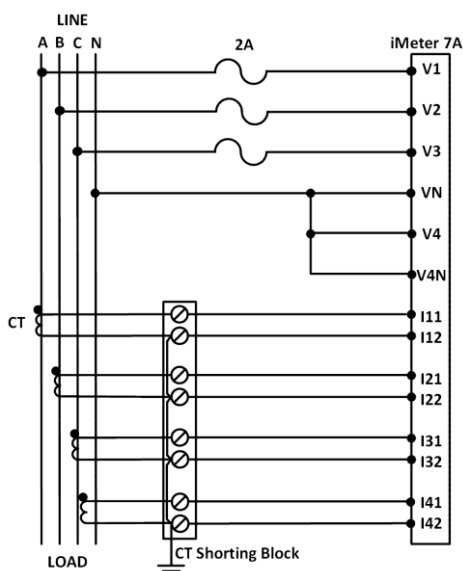

Figure 2-4 3-Phase 4-Wire Wye Direct Connection with 4CTs

2.5.2 3-Phase 4-Wire Wye with 3PTs and 4CTs

Please consult the serial number label to ensure that the rated PT secondary voltage is less than or equal to the device's voltage input specification. Set the **Wiring Mode** to 3P4W.

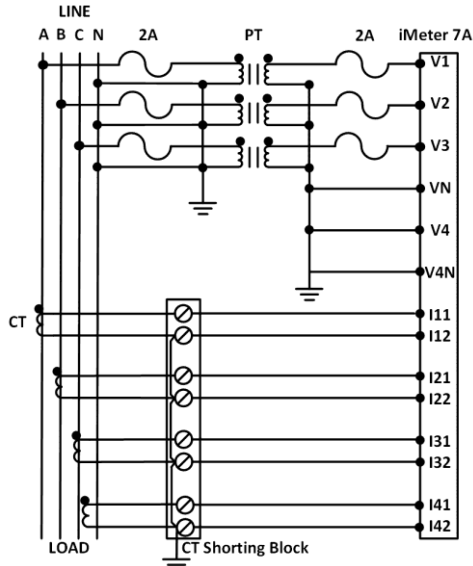

Figure 2-5 3-Phase 4-Wire Wye with 3PTs and 4CTs

2.5.3 3-Phase 3-Wire Grounded Wye with no PTs & 3CTs

Please consult the serial number label to ensure that the system phase voltage is less than or equal to the device's voltage input specification. Set the **Wiring Mode** to 3P4W.

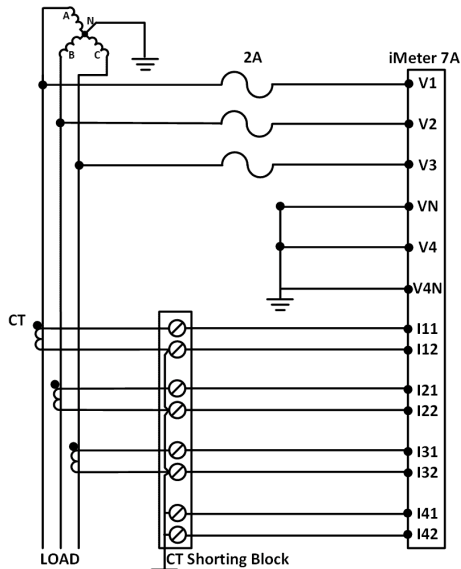

Figure 2-6 3-Phase 3-Wire Grounded Wye with no PTs & 3CTs

2.5.4 3-Phase 3-Wire Grounded Wye with 3PTs & 3CTs

Please consult the serial number label to ensure that the rated PT secondary voltage is less than or equal to the device's voltage input specification. Set the **Wiring Mode** to 3P4W.

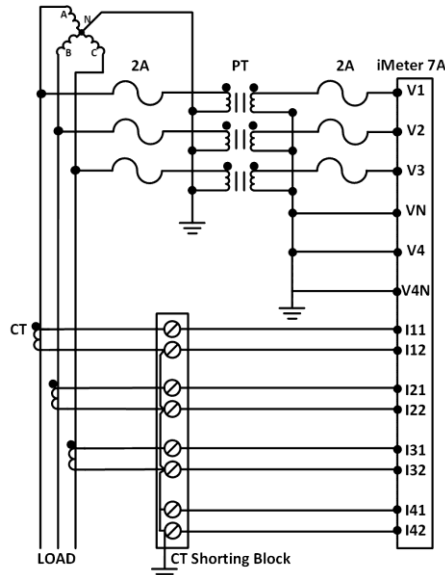

Figure 2-7 3-Phase 3-Wire Grounded Wye with 3PTs & 3CTs

2.5.5 3-Phase 3-Wire Delta Direct Connection with 3CTs

Please consult the serial number label to ensure that the rated PT secondary voltage is less than or equal to the device's voltage input specification. Set the **Wiring Mode** to 3P3W.

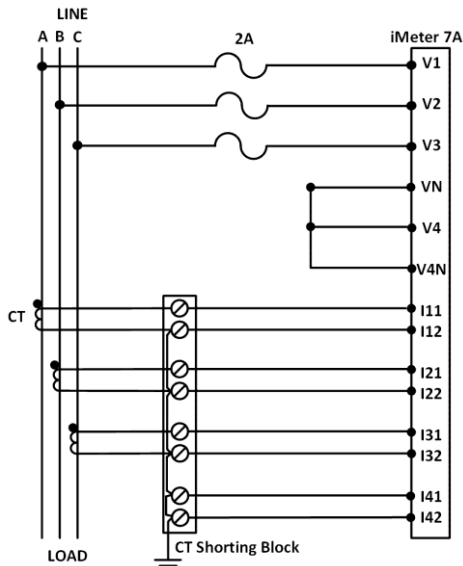

Figure 2-8 3-Phase 3-Wire Delta Direct Connection with 3CTs

2.5.6 3-Phase 3-Wire Open Delta with 2PTs & 3CTs

Please consult the serial number label to ensure that the rated PT secondary voltage is less than or equal to the device’s voltage input specification. Set the **Wiring Mode** to 3P3W.

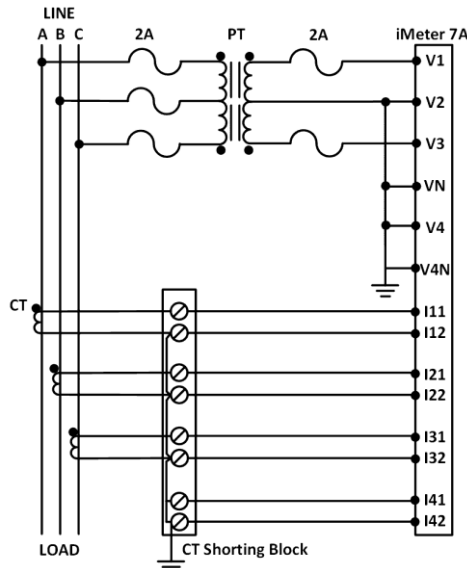

Figure 2-9 3-Phase 3-Wire Open Delta with 2PTs & 3CTs

2.5.7 3-Phase 3-Wire Open Delta with 2PTs & 2CTs

Please consult the serial number label to ensure that the rated PT secondary voltage is less than or equal to the device’s voltage input specification. Set the **Wiring Mode** to 3P3W.

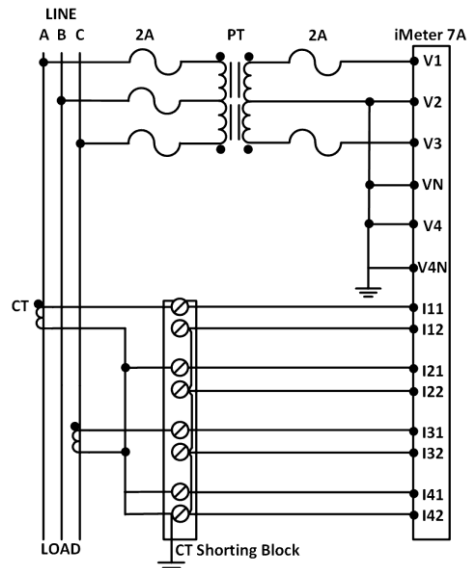

Figure 2-10 3-Phase 3-Wire Open Delta with 2PTs & 2CTs

2.6 Communications Wiring

2.6.1 Ethernet Port (10Base-T/100Base-TX)

2.6.1.1 Pin Description

RJ45 Connector	Pin	Meaning
	1	Transmit Data+
	2	Transmit Data-
	3	Receive Data+
	4,5,7,8,	NC
	6	Receive Data-

Table 2-1 RJ45 Connector Pin Description for 10/100BaseT Applications

2.6.1.2 Ethernet Mode

The iMeter 7A supports both **Normal Mode** and **Switch Mode** (Daisy-Chain) topologies illustrated in the following sections.

Normal Mode

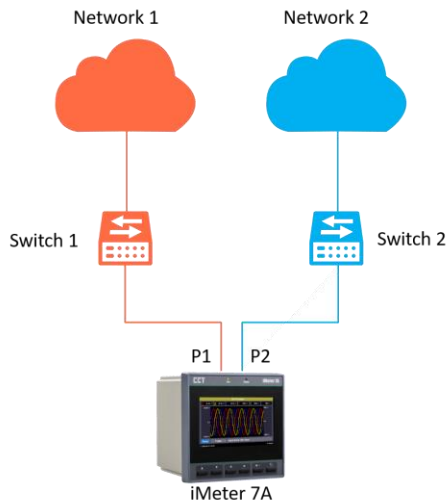

Switch Mode

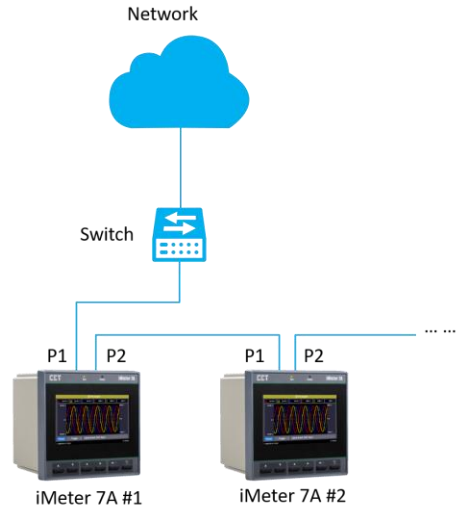

Figure 2-11 Ethernet Normal Mode and Switch Mode

In addition, the iMeter 7A also supports Rapid Spanning Tree Protocol (RSTP) to achieve optimal method for forwarding network traffic without any unnecessary redundancy.

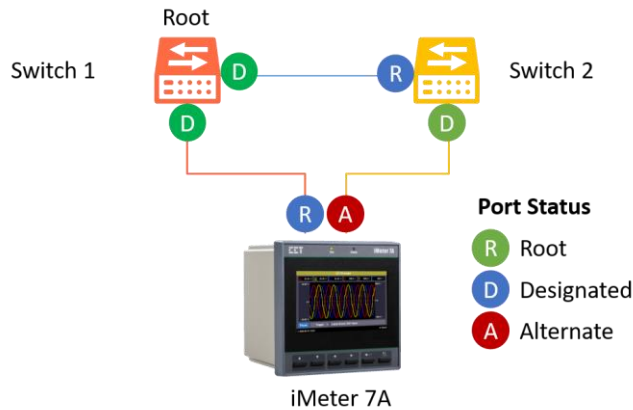

Figure 2-12 Ethernet RSTP Mode

2.6.2 RS-485 Port

The iMeter 7A provides one RS-485 port and supports the Modbus RTU protocol. Up to 32 devices can be connected on an RS-485 bus. The overall length of the RS-485 cable connecting all devices should not exceed 1200m.

If the master station does not have an RS-485 communications port, an Ethernet/RS-485 gateway or USB/RS-485 converter with optically isolated outputs and surge protection should be used.

The following figure illustrates the RS-485 communication connections on the iMeter 7A:

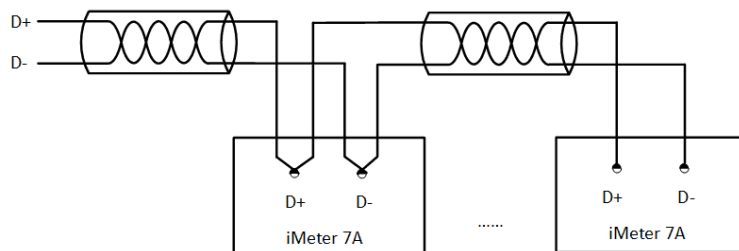

Figure 2-13 RS-485 Communication Connections

2.7 Chassis Ground Wiring

Connect the G terminal to the earth's ground.

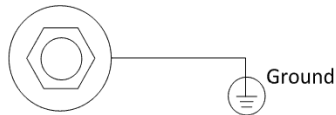

Figure 2-14 Chassis Ground Connection

2.8 Digital Input Wiring

The following figure illustrates the Digital Input connections on iMeter 7A:

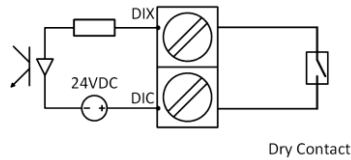

Figure 2-15 DI Connections

2.9 GPS 1PPS Input wiring

The GPS terminals on the iMeter 7A can be connected for GPS 1PPS Time Sync. or IRIG-B Time Sync.

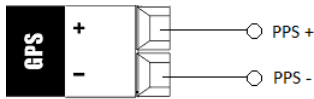

Figure 2-16 GPS 1PPS Time Sync.

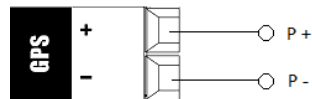

Figure 2-17 IRIG-B Time Sync.

2.10 Digital Output Wiring

The following figure illustrates the Digital Output connections on iMeter 7A:

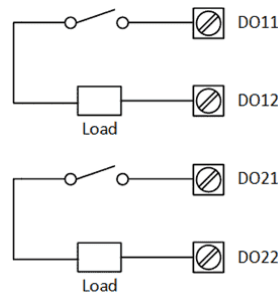

Figure 2-18 DO Connections

2.11 Alarm Output Wiring

The following figure illustrates the Alarm Output connections on the iMeter 7A when the LOP Alarm is enabled.

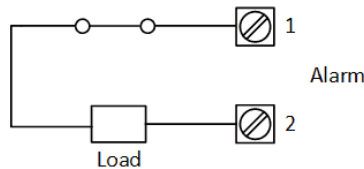

Figure 2-19 Alarm Output Wiring

2.12 RTD Input Wiring

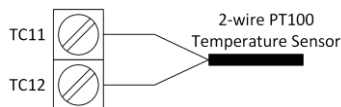

Figure 2-20 RTD Input Connections

2.13 Pulse Output Wiring

The following figure illustrates the Pulse Output connections on the iMeter 7A.

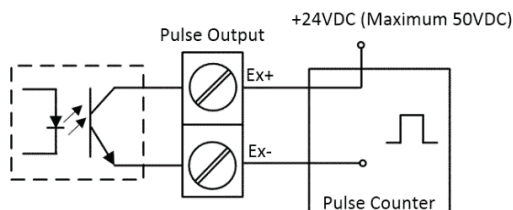

Figure 2-21 Pulse Output (Solid State Relay) Connections for Energy Pulsing

2.14 Analog Input Wiring

The following figure illustrates the Analog Input connections on the iMeter 7A

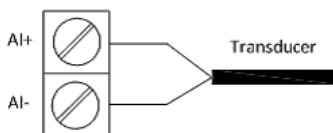

Figure 2-22 Analog Input Wiring

2.15 Power Supply Wiring

For AC supply, connect the live wire to the L/+ terminal and the neutral wire to the N/- terminal. For the DC supply, connect the positive wire to the L/+ terminal and the negative wire to the N/- terminal.

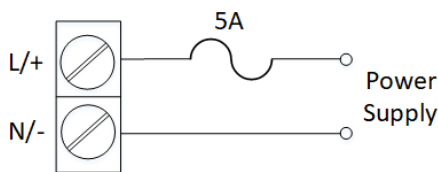

Figure 2-23 Power Supply Connections

Chapter 3 User Interface

3.1 Front Panel Interface

The following screen capture shows the Real-Time Waveform Capture display on the iMeter 7A, which is equipped with a backlit, 800x480, TFT Color, LCD Display. There are two LED indicators on the Front Panel for Run and Comm. status monitoring. The iMeter 7A also provides six buttons for data display and setup configuration.



Figure 3-1 Front Panel Interface

3.1.1 LED Indicator

The following table illustrates the definitions for LED indicators.

LED	Status	Description
Run	Blinking	The device is running normally
	Off	The device is running abnormally
Comm.	Blinking	Communication activity
	Off	Communication inactivity

Table 3-1 LED Indicator Definition

3.1.2 Front Panel Button

The iMeter 7A provides six buttons, <▲>, <▼>, <◀>, <▶>, <↔> and <⏻> for data display and setup configuration. The following table describes the basic functions of each button:

Buttons	Metering / Power Quality / PQ Insight / Event Menu	Setup Menu
<▲> <▼> <◀> <▶>	<p>The four arrow buttons are used for navigation between different menus on the Home Page. The current cursor location is indicated by a larger icon where its available sub-menus are listed at the bottom of the screen for reference.</p> <p>Before a sub-menu is selected,</p> <ul style="list-style-type: none"> Press <▲> or <▼> to navigate the sub-menu list. <p>After a sub-menu is selected,</p> <ul style="list-style-type: none"> Press <◀> or <▶> to display different pages of parameters. Use <▲> or <▼> to scroll to different pages of Individual Harmonic or Interharmonic measurements from 1st to 63rd in the Harmonics or Interharmonics sub-menu. In the WFR and DWR page, press <◀> or <▶> to scroll backward or forward through the waveform and <▲> or <▼> to zoom in/out of the waveform. 	<p>Before a parameter is selected,</p> <ul style="list-style-type: none"> Use <◀>, <▶>, <▲> and <▼> buttons to navigate around. <p>If a parameter is selected,</p> <ul style="list-style-type: none"> For a numeric parameter, press <▲> or <▼> to increment or decrement a numeric value. For an enumerated parameter, press <▲> or <▼> to scroll through the selection list.
<↔>	<ul style="list-style-type: none"> Press <↔> to enter the selected Menu/Sub-menu In TOU, press <↔> to toggle between Energy and Max. Demand. In Max., Min., and 2-150kHz C.E., press <↔> to scroll through different pages of measurements. In Harmonics / Interharmonics, press <↔> to view the Individual Harmonics or Interharmonics details. In PQ Insight, press <↔> to Pause/Refresh the WF Capture, toggle the signal selection for WF display, manually trigger WFR/DWR or view the latest event details. 	<p>Before a parameter is selected,</p> <ul style="list-style-type: none"> pressing <↔> selects a parameter for modification. <p>After a parameter is selected,</p> <ul style="list-style-type: none"> pressing <↔> saves the present value of the selected parameter into memory.
<⏻>	<ul style="list-style-type: none"> Press <⏻> to exit the current display. 	<p>Press <⏻> to cancel the change.</p>
<▼> + <⏻>	<p>Press this key combination to toggle between the Summary and Large Font display in RMS, Energy (RMS only), Demand, TOU, Harmonics and Interharmonics.</p>	

Table 3-2 Front Panel Button Description

3.1.3 Front Panel Display

The Front Panel Display allows the user to view data and perform basic configuration. The main menu consists of 5 items, **Metering**, **Power Quality**, **PQ Insight**, **Events** and **Setup**. Each item consists of a sub-menus for detailed data viewing or setup configuration. All data and setup parameters can be viewed without a password, but a valid **Front Panel Password** is required for making setup changes. The default **Front Panel Password** is 000001.

The following figure provides an overview of the menus.

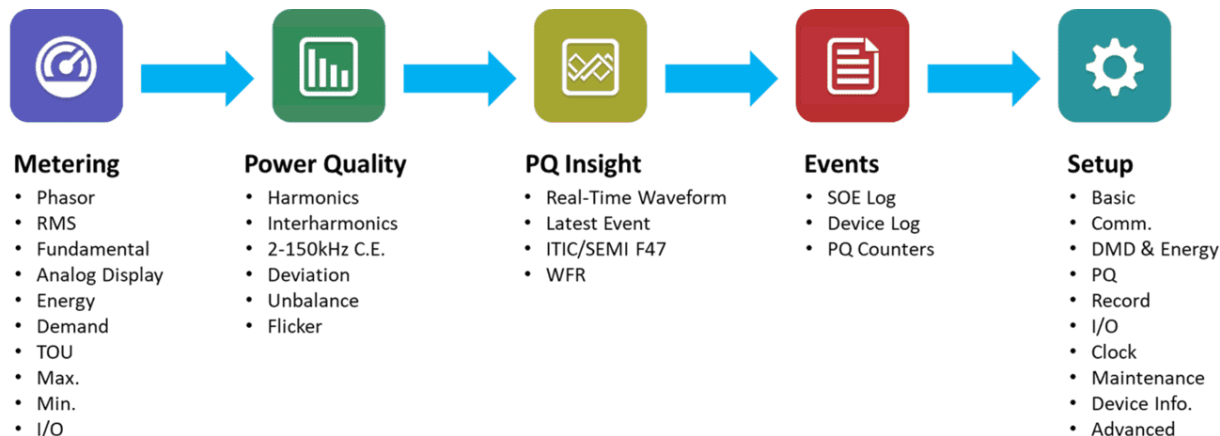

Figure 3-2 Front Panel Data Display

3.1.3.1 Metering

The **Metering** menu consists of **Phasor**, **RMS**, **Fundamental**, **Analog Display**, **Energy**, **Demand**, **TOU**, **Max.**, **Min.** and **I/O**. The following sections provide an overview of this sub-menus.

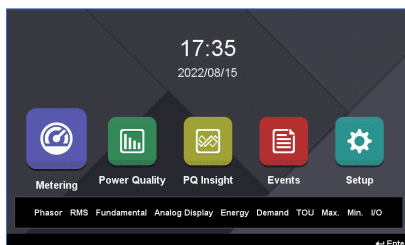

Figure 3-3 Metering

3.1.3.1.1 Phasor

Enter the **Phasor** sub-menu and the following screen appears which displays the Magnitude and Phase Information.

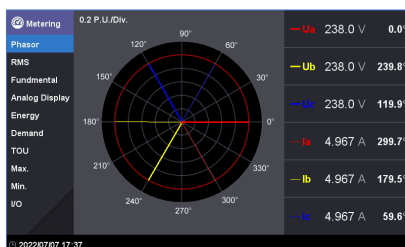

Figure 3-4 Phasor

3.1.3.1.2 RMS

Enter the **RMS** sub-menu and the 3- Φ and Tot/Avg. RMS measurements updated @1s for Uln, Ull, I, P, Q, S and PF as well as U4, Ung, I4, IR, OT (Operating Time) and Frequency are displayed.

Press \blacktriangledown & \blacklozenge simultaneously to enter the large font display and then use \blacktriangleleft or \blacktriangleright to scroll between the different screens. Press \blacktriangledown & \blacklozenge simultaneously again to return to the summary mode.

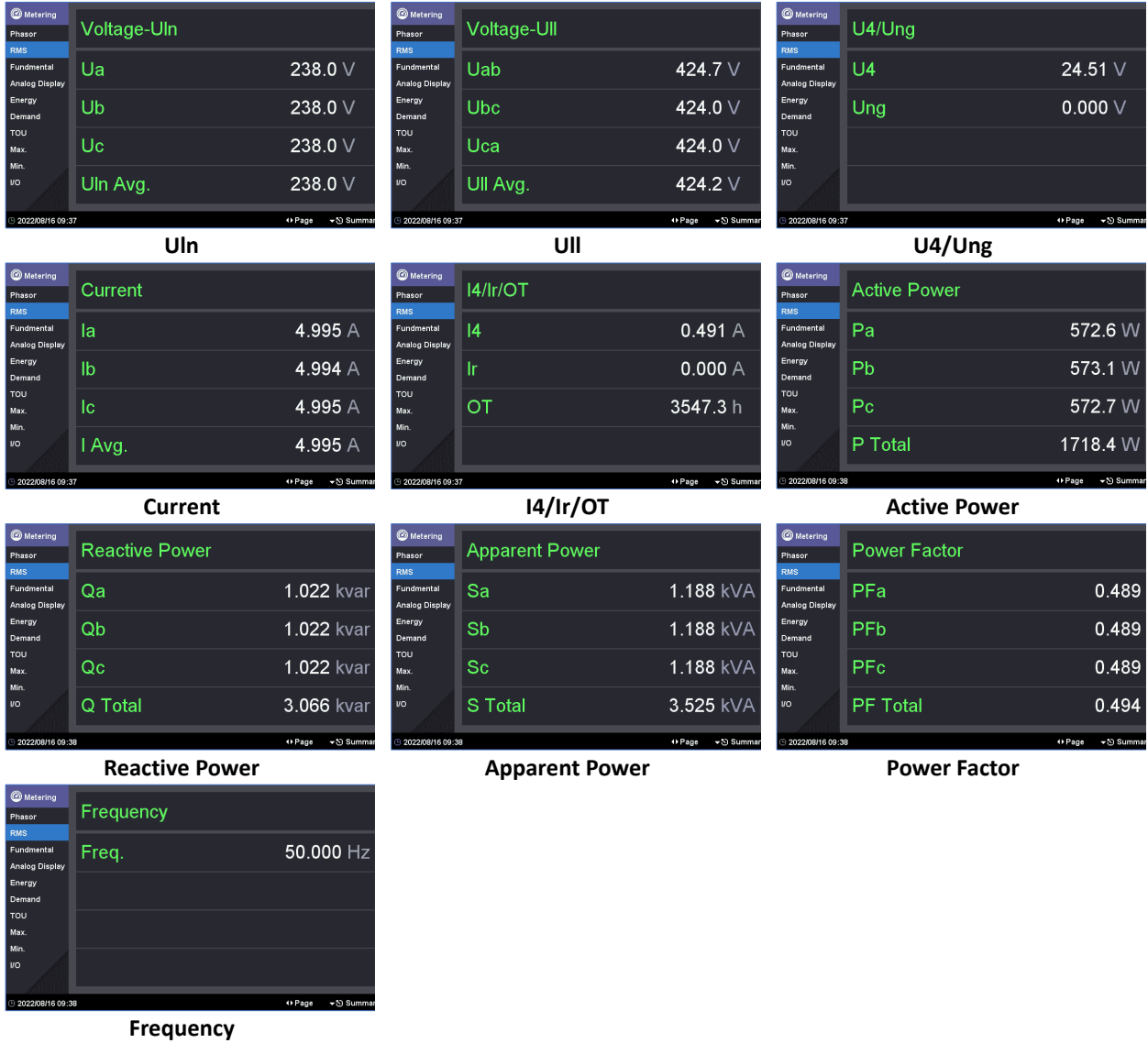

Figure 3-5 RMS Large Font Displays

3.1.3.1.3 Fundamental

Enter the **Fundamental** sub-menu and the 3- Φ and Tot/Avg. Fundamental measurements updated @ 1s Uln, Ull, I, P, Q, S and dPF as well as 3- Φ U Angle, 3- Φ I Angle, U4 and I4 are displayed.

Press \blacktriangleleft or \blacktriangleright button to scroll among **Voltage, Current and Power** Measurements.

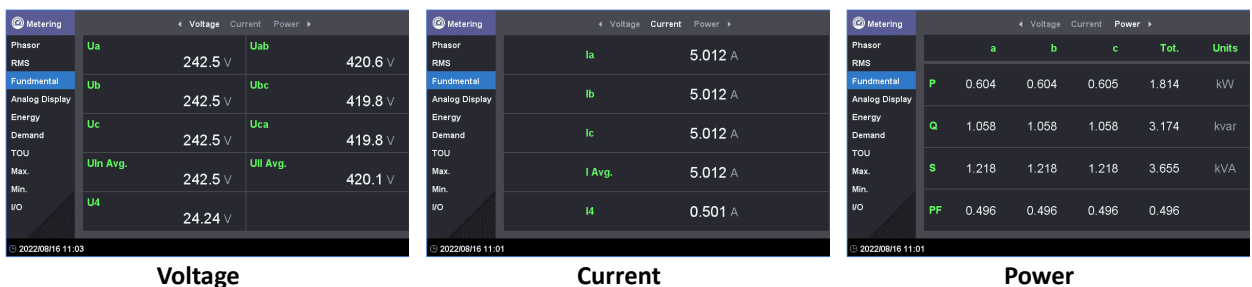

Figure 3-6 Fundamental Measurements

3.1.3.1.4 Analog Display

Enter the **Analog Display** sub-menu and the following screen appears which shows the Analog display as well as the Trend Curve for the per phase Uln and I or Ull and I.

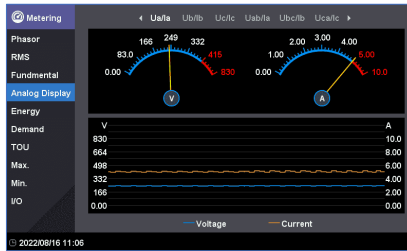

Figure 3-7 Analog Display

3.1.3.1.5 Energy

Enter the **Energy** sub-menu and the following screens are available which provide the measurements for kWh, kvarh Import/Export/Total/Net and kVAh Total.

Press <◀> or <▶> button to scroll among **RMS**, **Fund.** and **Tot. Harm.** Measurements.

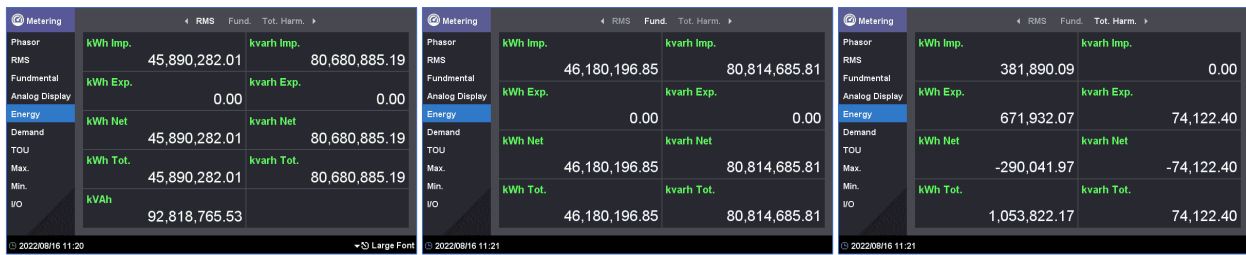

Figure 3-8 Energy Measurements

At the **RMS Energy** screen, press <▼> & <⏏> simultaneously to enter the large font display and then use <◀> or <▶> to scroll between the different screens. Press <▼> & <⏏> simultaneously again to return to the **RMS Energy** summary.

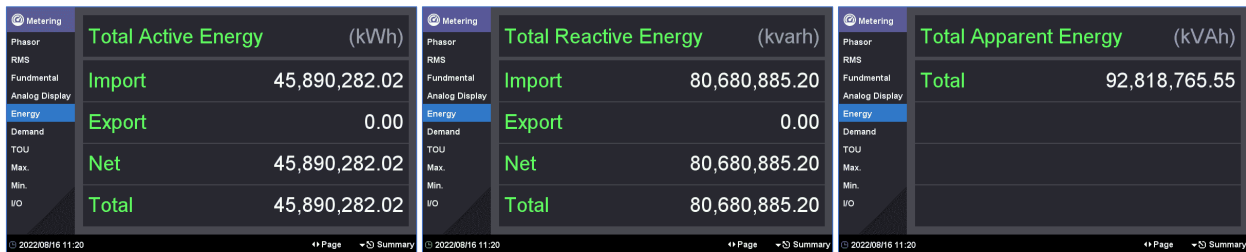

Figure 3-9 Large Font Displays for RMS Energy Measurements

3.1.3.1.6 Demand

Enter the **Demand** sub-menu and the following screens are available which display the Present Demand, Predicted Demand, This Max. and Last Max. for P Total Imp/Exp, Q Total Imp/Exp, S and 3-Φ Currents. Use <◀> or <▶> button to scroll among **Present** (including **Present & Predicted Demand**), **This Max.** and **Last Max.** with their timestamps. Depending on the setting of the **Self-Read Time**, **This Max.** and **Last Max.** could mean the Max. Demand of This Month/Last Month or Since/Before the Last Reset.



Figure 3-10 Demands Summary

At the **Present Demand** screen, press \blacktriangledown & \odot simultaneously to enter the large font display and use \blacktriangleleft or \blacktriangleright to scroll between the different screens. Press \blacktriangledown & \odot simultaneously again to return to the summary screen.



Figure 3-11 Present Demand Large Font Displays

At the **This Max. Demand** screen, press \blacktriangledown & \odot simultaneously to enter the large font display and use \blacktriangleleft or \blacktriangleright to scroll between the different screens. Press \blacktriangledown & \odot simultaneously again to return to the summary screen.



Figure 3-12 This Max. Demand Large Font Displays

At the **Last Max. Demand** screen, press \blacktriangledown & \odot simultaneously to enter the large font display and use \blacktriangleleft or \blacktriangleright to scroll between the different screens. Press \blacktriangledown & \odot simultaneously again to return to the summary screen.



Figure 3-13 Last Max. Demand Large Font Displays

3.1.3.1.7 TOU

Enter the **TOU** sub-menu and the following screens are available. Use \leftrightarrow to scroll between **TOU Energy** and **Max. Demand Summary**.

The **TOU Energy Summary** screen displays the Present Tariff/Season/Daily Profile as well as the kWh Import/Export, kvarh Import/Export and kVAh for the different Tariffs.

The **TOU Max. Demand Summary** screen displays the P Total Import/Export, and Q Total Import/Export maximum demand with the timestamp for the different Tariffs.

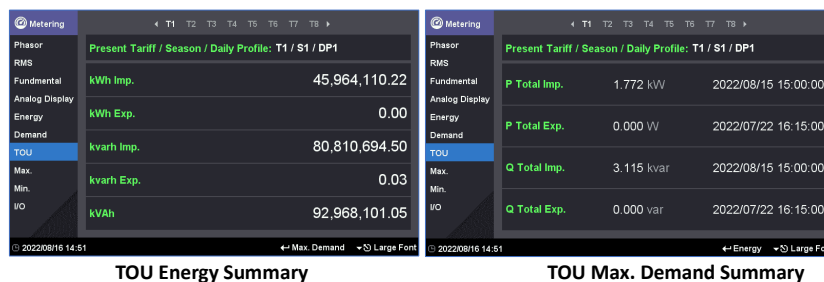

Figure 3-14 Present and Last TOU Summary

At the **TOU Energy Summary** or **TOU Max. Demand Summary** screen, press \blacktriangledown & \odot together to enter the large font display and use \blacktriangleleft or \blacktriangleright to scroll between the different screens. Press \blacktriangledown & \odot simultaneously again to return to the summary screen.



Figure 3-15 TOU Energy/Max. Demand Large Font Displays

3.1.3.1.8 Max.

Enter the **Max.** sub-menu and the following screens are available which display the Max. measurements with timestamps. Press <◀> or <▶> to scroll among the 4 Max. Recorders and then Use <↔> to scroll to the different parameters.



Figure 3-16 Max. Measurements

3.1.3.1.9 Min.

Enter the **Min.** sub-menu and the following screen is available which displays the Min. measurements with timestamps. Press <◀> or <▶> to scroll among the 4 Max. Recorders and then Use <↔> to scroll to the different parameters.



Figure 3-17 Min. Measurements

3.1.3.1.10 I/O

Enter the **I/O** sub-menu and the following screens are available which display the DI function and status (or measurement), DO status and optional AI/TC measurements.

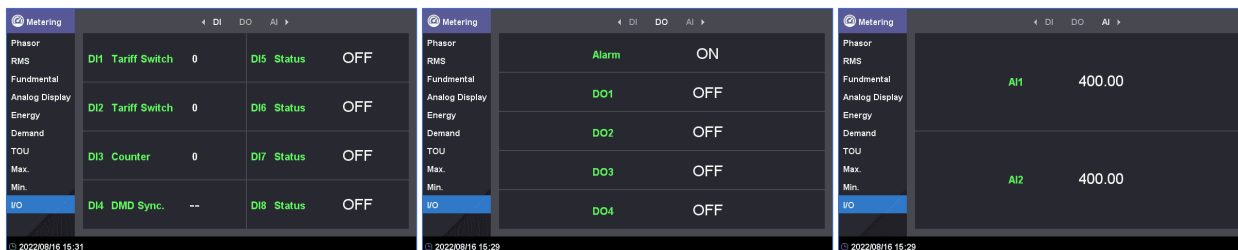

Figure 3-18 I/O

3.1.3.2 Power Quality

The **Power Quality** menu includes **Harmonics**, **Interharmonics**, **2kHz-150kHz C.E.**, **Deviation**, **Unbalance**, and **Flicker**. The following sections provide a quick overview of these screens.

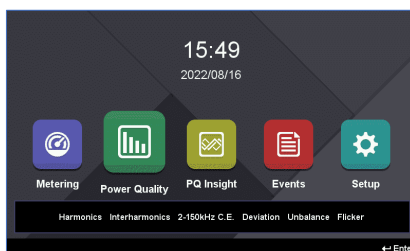

Figure 3-19 Power Quality menu

3.1.3.2.1 Harmonics

Enter the **Harmonics** sub-menu and the following screens are available.

Use <◀> or <▶> to scroll among the **Harmonics Overview** for 4-Φ Voltages and 4-Φ Currents. The **Voltage Harmonics** screen shows the Voltage Harmonic Spectrum, THD, TOHD, TEHD and Crest Factor while the **Current Harmonics** screen shows the Current Harmonic Spectrum, THD, TOHD, TEHD, Crest Factor, TDD, TDD Odd, TDD Even, and K-Factor.

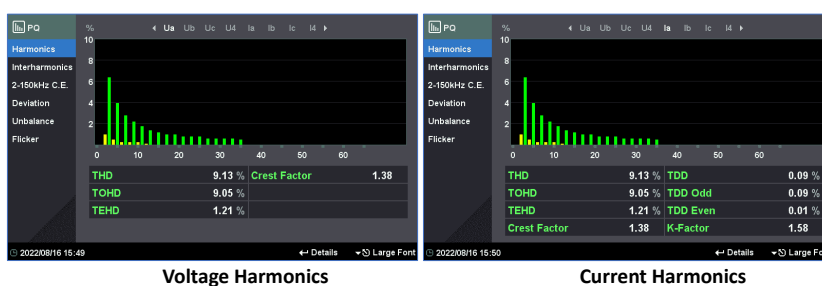

Figure 3-20 Harmonics Overview

At the **Voltage** and **Current Harmonics** screens, press <▼> & <Ⓜ> simultaneously to enter the large font display and use <◀> or <▶> to scroll between the different screens. Press <▼> & <Ⓜ> simultaneously again to return to the previous level.

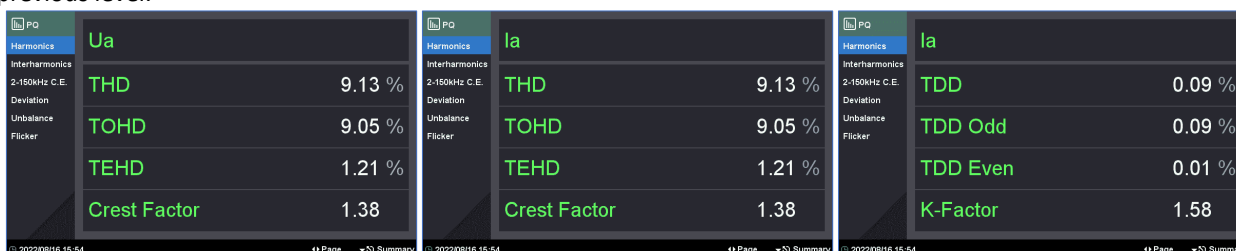

Figure 3-21 Voltage and Current Harmonics Large Font Displays

At the **Voltage** and **Current Harmonics** screens, press <↔> to view the %HD, RMS and Angle measurements for Voltage and Current for the respective individual harmonics.

Order	%HD	RMS	Angle
01	100.00 %	240.4 V	0.0°
02	1.00 %	2.409 V	60.0°
03	6.40 %	15.38 V	60.0°
04	0.50 %	1.199 V	60.0°
05	4.00 %	9.614 V	60.0°
06	0.26 %	0.625 V	60.0°
07	2.80 %	6.728 V	60.0°
08	0.26 %	0.626 V	60.0°
09	2.20 %	5.287 V	60.0°
10	0.26 %	0.624 V	60.0°

Individual Harmonics
Figure 3-22 Individual Harmonics

3.1.3.2.2 Interharmonics

Enter the **Interharmonics** sub-menu and the following screens are available. Use << or >> to scroll between the 4- Φ **Voltage and Current Interharmonics**. Each screen provides the Interharmonic Spectrum, TIHD, TOIHD and TEIHD measurements.



Figure 3-23 Interharmonics

At the **Voltage** and **Current Interharmonics** screens, press <v> & <f> simultaneously to enter the large font display and use << or >> to scroll between the different parameters. Press <v> & <f> simultaneously again to return to the previous level.



Figure 3-24 Interharmonics Large Font Displays

At the **Voltage** and **Current Interharmonics** screens, press <f> to view the %IHD and RMS measurements for 4- Φ Voltages and Currents from IH01 to IH63.



Figure 3-25 Individual Interharmonics

3.1.3.2.3 2-150kHz C.E.

Enter the **2-150kHz C.E.** sub-menu and the following screens are available. Use << or >> to scroll among Voltage measurements at 2kHz – 9kHz and 9kHz – 150kHz frequency bands and Current measurements at 2kHz to 9kHz frequency bands. Press <f> to view the 3- Φ U_{rms} / I_{rms} C.E. for different segments.



Figure 3-26 2kHz - 150kHz C.E.

3.1.3.2.4 Deviation

Enter the **Deviation** sub-menu and the following screen appears which displays the Over/Under Deviation measurements for 3- Φ UIn and Ull as well as the Frequency Deviation measurement.



Figure 3-27 Deviation

3.1.3.2.5 Unbalance

Enter the **Unbalance** sub-menu to display the Positive/Negative/Zero Sequence measurements for Voltage and Current as well as the Negative Sequence (U2/I2) and Zero Sequence (U0/I0) Unbalance measurements.

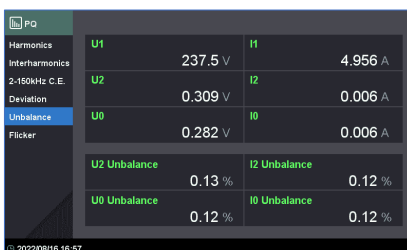

Figure 3-28 Unbalance

3.1.3.2.6 Flicker

Enter the **Flicker** sub-menu to display the Pst and Plt measurements for 3- Φ Voltages.

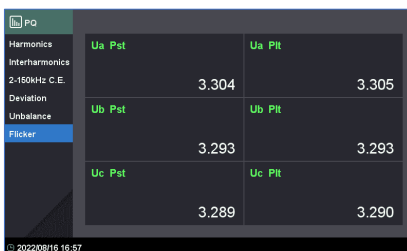

Figure 3-29 Flicker

3.1.3.3 PQ Insight

The **PQ Insight** menu mainly provides the Real-Time Waveform display.

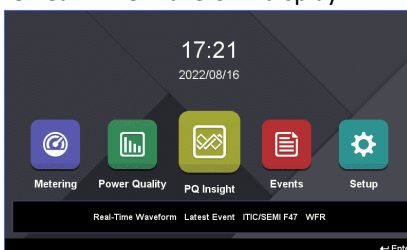

Figure 3-30 PQ Insight

3.1.3.3.1 Real-Time Waveform Capture (WFC)

This screen shows the Real-Time WFC for 3- Φ Voltages and Currents at 128 samples/cycle for 4 cycles that is updated every second. Press <↵> to enter the display and then use <▲>, <▼>, <◀>, <▶> and <↵> to navigate around the screen. One can toggle the display of a particular Voltage or Current Channel, **Pause/Refresh** the WFC update, manually trigger a WFR (Waveform Recorder), DWR (Disturbance Waveform Recorder) or iTrigger Recorder, or check the details of the latest SOE event displayed at the bottom of the screen with ITIC/SEMI Curves and WFR/DWR waveforms.

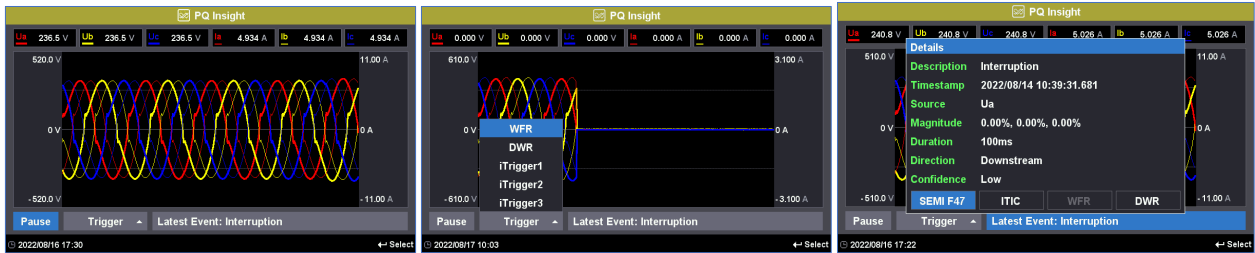

Figure 3-31 Real-Time Waveform

3.1.3.4 Events

The **Events** menu consists of **SOE Log**, **Device Log** and **PQ Counters**. The following sections provide a quick overview of these screens.

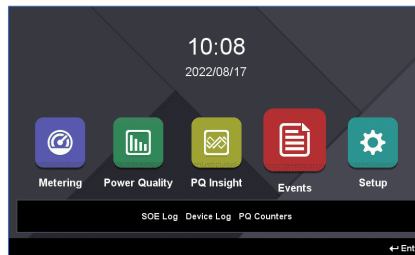

Figure 3-32 Events

3.1.3.4.1 SOE Log

Enter the **SOE Log** sub-menu and the following screens are available. The **SOE Log** displays up to 1024 events starting with the most recent event. Use <◀> or <▶> to quickly move through the pages. Press <↵> to enter the display and then use <▲> or <▼> to scroll through the event list. Press <↵> to select and view the event details.

No.	Timestamp	Description
17	2022/07/08 09:09:40.766	Swell
18	2022/07/07 17:44:48.757	DO1 Open
19	2022/07/07 17:44:48.754	Over Uln SP Return
20	2022/07/07 17:44:48.747	DO1 Closed
21	2022/07/07 17:44:48.744	Over Uln SP Active
22	2022/07/07 17:44:48.747	DO1 Open
23	2022/07/07 17:44:48.744	Over Uln SP Return
24	2022/07/07 17:44:42.747	DO1 Closed

Figure 3-33 SOE Log

If the selected event is a PQ event, the **Details** dialog box may provide the options for displaying the SEMI F47/ITIC curves or the WFR and/or DWR waveform display. Press <◀> or <▶> to select the option and then press <↵> to select and view the respective display.



Figure 3-34 Event Detail

Here are some examples of these displays:

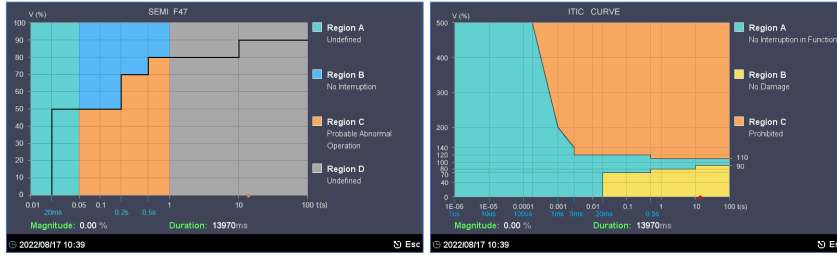

Figure 3-35 Examples for SEMI F47/ITIC Curve

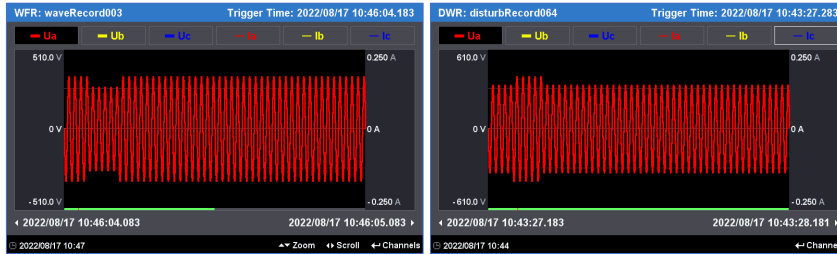

Figure 3-36 Examples of WFR (Dip) /DWR (Swell)

Inside the waveform display, press \blacktriangle or \blacktriangledown to zoom in/out of the waveform or press \blacktriangleleft or \blacktriangleright to scroll backward/forward of the waveform on the time scale.

3.1.3.4.2 Device Log

Enter the **Device Log** sub-menu and the following screens are available. The **Device Log** displays up to 1024 events starting with the most recent event. Use \blacktriangleleft or \blacktriangleright to quickly move through the pages.

No.	Timestamp	Description
1	2022/08/17 10:07:50.729	Setup Changes
2	2022/08/17 10:08:31.799	Setup Changes
3	2022/08/16 15:31:10.209	Tariff Switch by DI enabled (T1)
4	2022/08/16 15:31:05.705	Setup Changes
5	2022/08/15 17:34:06.907	Setup Changes
6	2022/08/15 14:36:10.000	Power On
7	2022/08/15 14:33:57.000	Power Off
8	2022/08/14 10:39:06.556	Setup Changes

Figure 3-37 Device Log

3.1.3.4.3 PQ Counters

Enter the **PQ Counters** sub-menu to display the different PQ Event counters.

Supply Voltage Swells	30	Inrush Current	0
Supply Voltage Dips	32	MSV 1,000.00Hz	0
Supply Voltage Interruptions	8	MSV 2,000.00Hz	0
Transient Overvoltages	3	MSV 3,000.00Hz	0
Rapid Voltage Changes	0	Total	73

Figure 3-38 PQ Counters

3.1.3.5 Setup

The **Setup** menu consists of **Basic**, **Comm.**, **DMD & Energy**, **PQ**, **Record**, **I/O**, **Clock**, **HMI & Pwd**, **Maintenance**, **Device Info.** and **Advanced**. The following sections provide a quick overview of these screens.

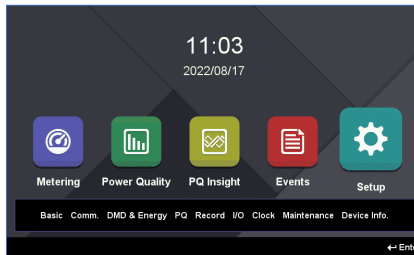

Figure 3-39 Setup Menu

3.1.3.5.1 Basic

Enter the **Basic** sub-menu and the following screens are available. Use << or >> to scroll between **Wiring** and **PT/CT** setup. Press <▲> or <▼> to scroll among different parameters. Press <↵> to select and modify the desired parameter. The Front Panel Password is required for any setup changes. Please refer to **Table 3-5** for the range and default values of the different parameters.



Wiring Setup

PT/CT Setup

Figure 3-40 Basic Setup

3.1.3.5.2 Comm.

Enter the **Comm.** sub-menu and the following screens are available. Use << or >> to scroll among **Ethernet**, **RS-485**, **Advanced 1**, **Advanced 2** and **Cloud** settings. Please refer to **Table 3-6** and **Table 3-7** for the range and default values of the different parameters.

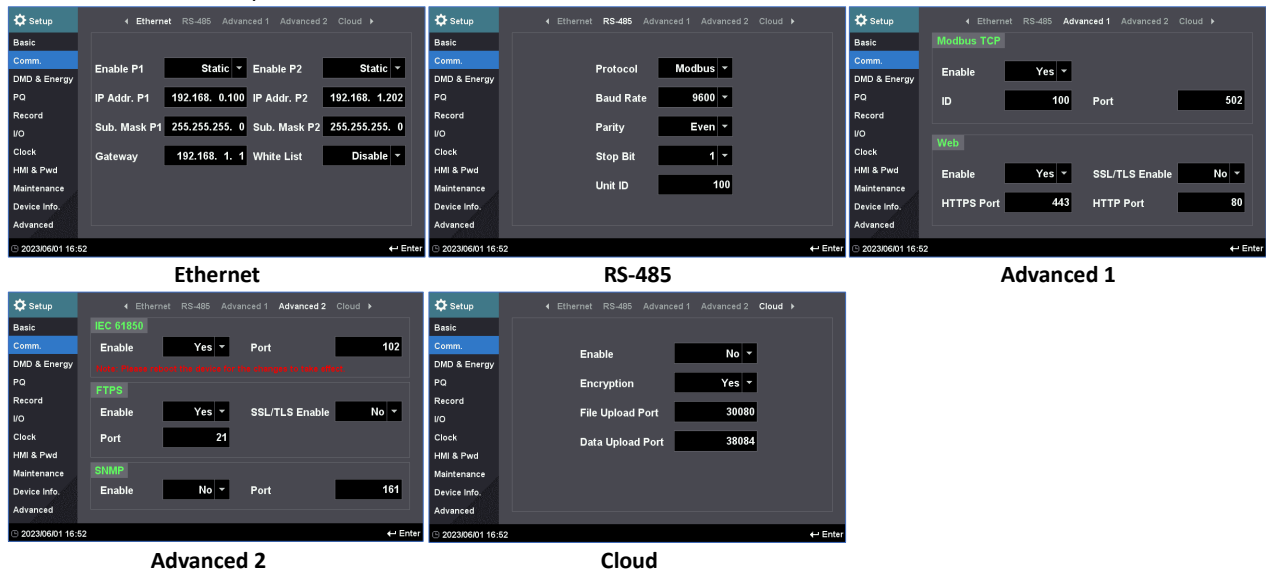

Ethernet

RS-485

Advanced 1

Advanced 2

Cloud

Figure 3-41 Comm. Setup

3.1.3.5.3 DMD & Energy

Enter the **DMD & Energy** sub-menu and the following screen are available. Use <<> or <>> to scroll among **Demand**, **Energy Log**, **Energy Pulse (optional)** and **Algorithm** settings.

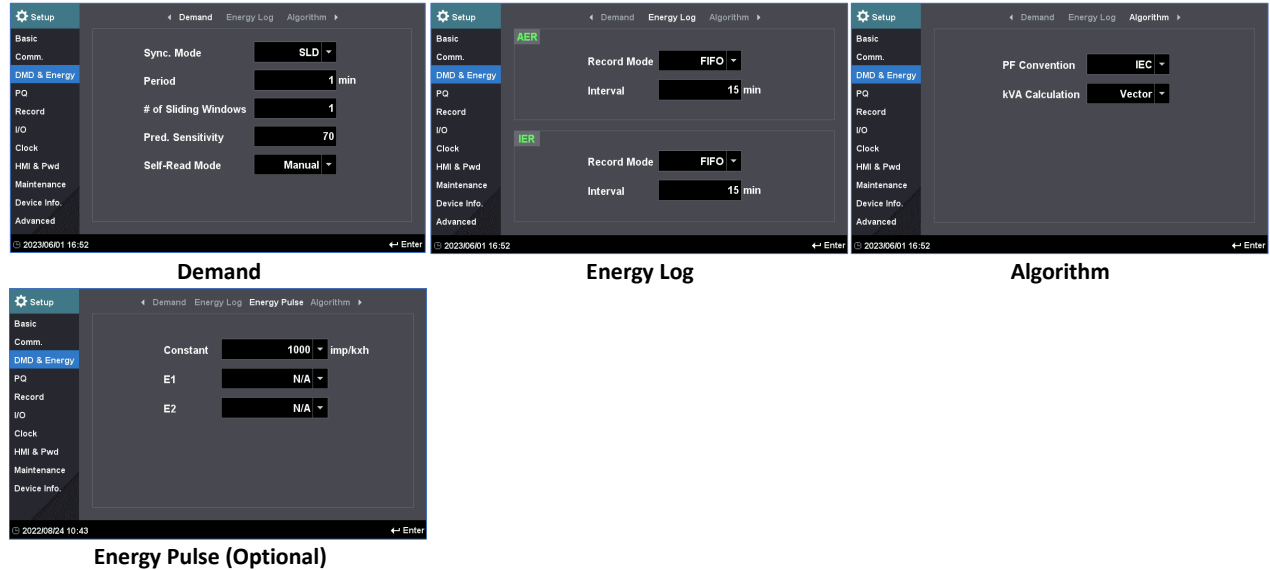

Figure 3-42 DMD & Energy Setup

3.1.3.5.4 PQ

Enter the **PQ** Sub-menu and the following screens are available. Use <<> or <>> to scroll among **PQD**, **Transient**, **RVC**, **Inrush Current**, **Harmonics** and **Flicker** settings.



Figure 3-43 PQ Setup

3.1.3.5.5 Record

Enter the **Record** sub-menu and the following screens are available. Use <◀> or <▶> to scroll among **WFR**, **DWR**, **RMSR** and **iTrigger** settings.

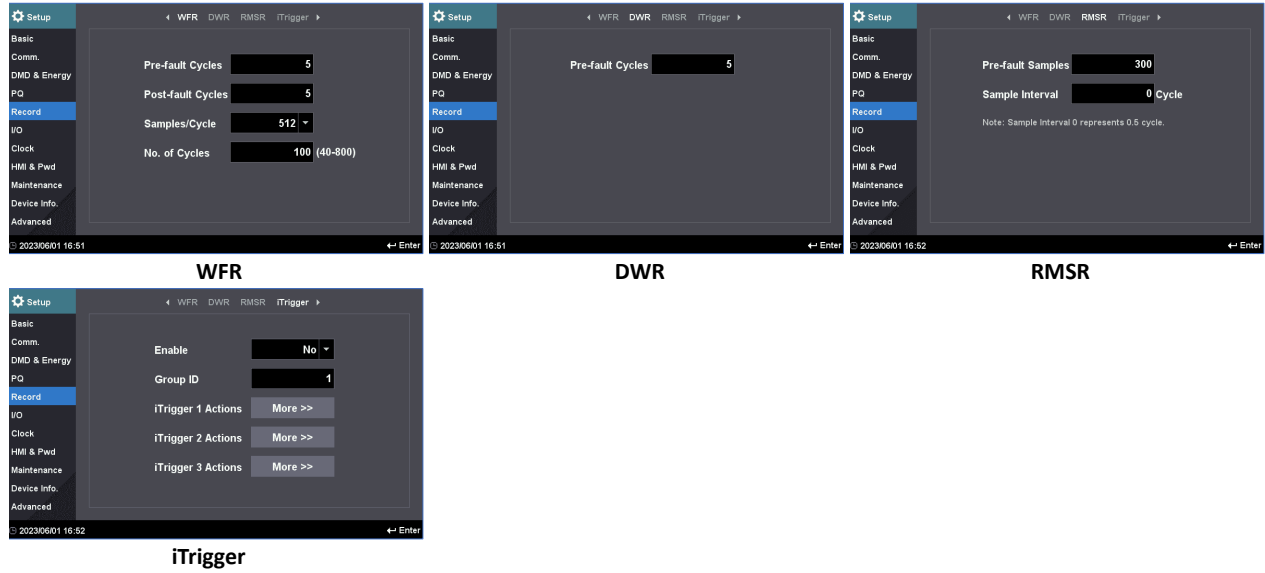

Figure 3-44 Record Setup

3.1.3.5.6 I/O

Enter the **I/O** sub-menu and the following settings are available. Use <◀> or <▶> to scroll among **DI**, **DO** and optional **AI** settings. Please refer to **Section 4.1** for the range and default values.



Figure 3-45 I/O Setup Interface

3.1.3.5.7 Clock

Enter the **Clock** sub-menu to display the Clock and Time Sync. settings. Please refer to **Section 4.9** for the range and default value.

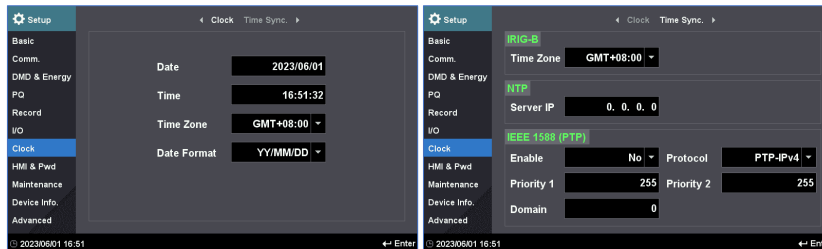

Figure 3-46 Clock Setup Interface

3.1.3.5.8 HMI & Pwd

Enter the **HMI & Pwd** sub-menu to display the settings for HMI and Password. The current password is required to change the password.



Figure 3-47 Password Setup Interface

3.1.3.5.9 Maintenance

Enter the **Maintenance** sub-menu and the following screens are available which allow the manual control of DO, reset of the different groups of parameters and device reboot.

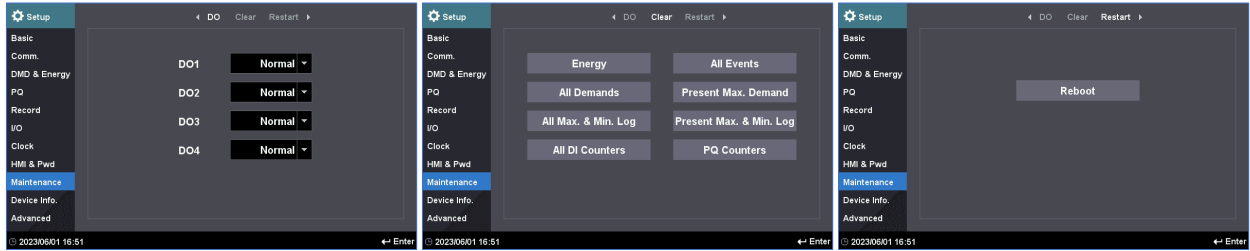

Figure 3-48 Maintenance

- DO** Force DO On/Off or return DO to Normal control.
- Clear** Perform the various reset operations.
- Restart** Reboot the Device.

3.1.3.5.10 Device Info.

Enter the **Device Info.** sub-menu and the following information are available.

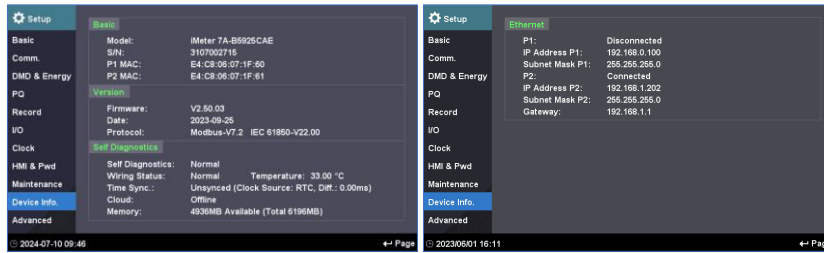

Figure 3-49 Device Info.

3.1.3.5.11 Advanced

Enter the **Advanced** sub-menu and the following advanced settings are available.

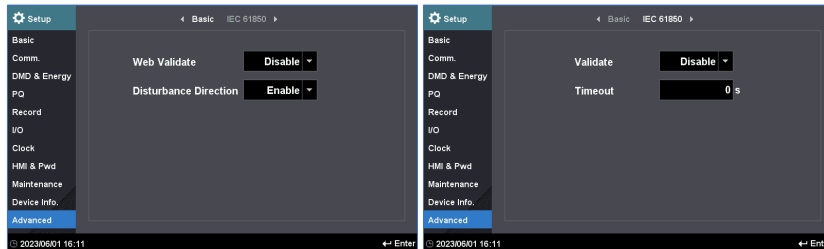

Figure 3-50 Advanced Setup

3.2 On-board Web Interface



The iMeter 7A's Web Interface is compatible with various web browsers.

Browser	Browser Version
Google Chrome	V103.0.5060.134 and above
Microsoft Edge	V103.0.1264.71 and above
Firefox	V102.0.1 and above

Table 3-3 Web Browser Supported

The default IP Addresses of the iMeter 7A's Ethernet Port are 192.168.0.100 (P1) and 192.168.1.100 (P2). Please make sure to configure the IP Address, Subnet Mask and Default Gateway such that it's on the same subnet as the PC that is being used to access the meter.

3.2.1 Setting PC's IP Address

To determine the PC's IP Address, click the **Start** icon , then the **Settings** button  on Windows 10 (for other MS Windows systems, please refer to this [link](#) for more instructions).

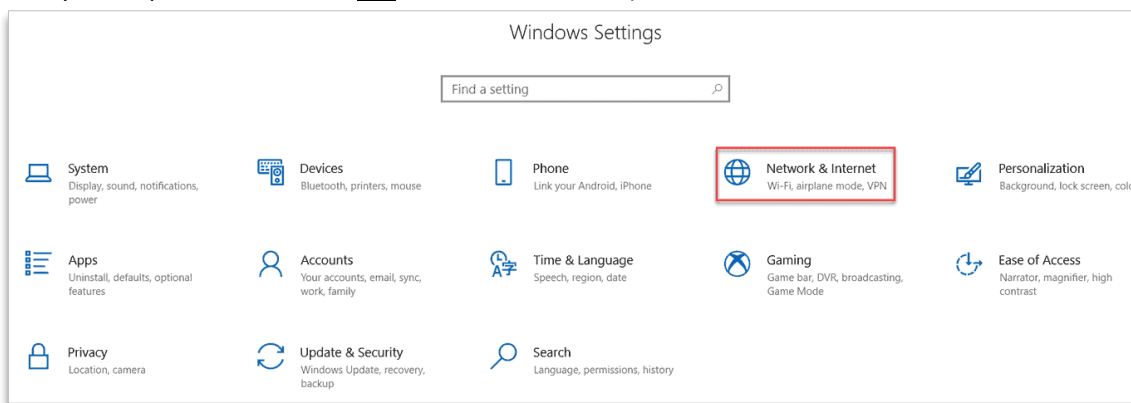

Figure 3-51 Settings-> Network & Internet

Click  **Network & Internet**, select the **Change adapter options** and then find the appropriate Ethernet connection.



Figure 3-52 Network and Sharing Center

Right-click on it and select **Properties**. Then double-click on **Internet Protocol Version 4 (TCP/IPv4)** to show its IP configuration.

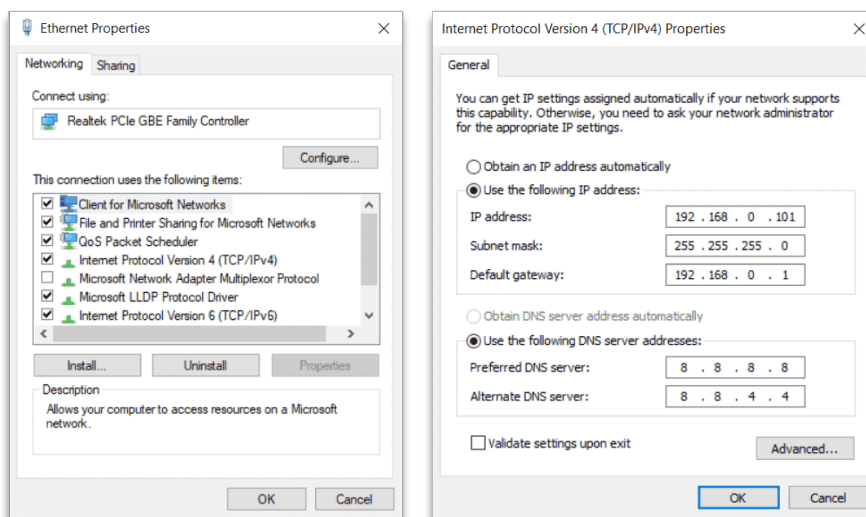

Figure 3-53 Setting PC's IP Address

3.2.2 Configure iMeter 7A's IP Address

The iMeter 7A's IP address can be retrieved automatically from the DHCP server or be configured with a static address. The default setting of the iMeter 7A is to obtain an IP address by manual configuration. Under **Enable P1/P2 = Static** setting in the **Setup > Comm. > Ethernet** menu on the Front Panel, set the **IP Address, Sub. Mask, Gateway** accordingly.

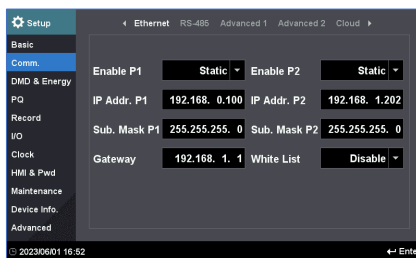

Figure 3-54 Manually Configure IP Address via Front Panel

If **DHCP** is used for IP addressing mode, the current IP address can be found in the **Setup > Device Info. > Ethernet** menu on the Front Panel.



Figure 3-55 IP Address Information on the Front Panel

3.2.3 Accessing Web Interface

- 1) If the Web Client Validate is enabled (disabled by default), it's required to import the HTTPS certificate for web validation in **Google Chrome** as follows (if Client Validate is disabled, skip this step). Please contact CET Technical Support to obtain an HTTPS certificate.
 - a. Click the **Menu** icon on **Chrome** and then select **Settings**.

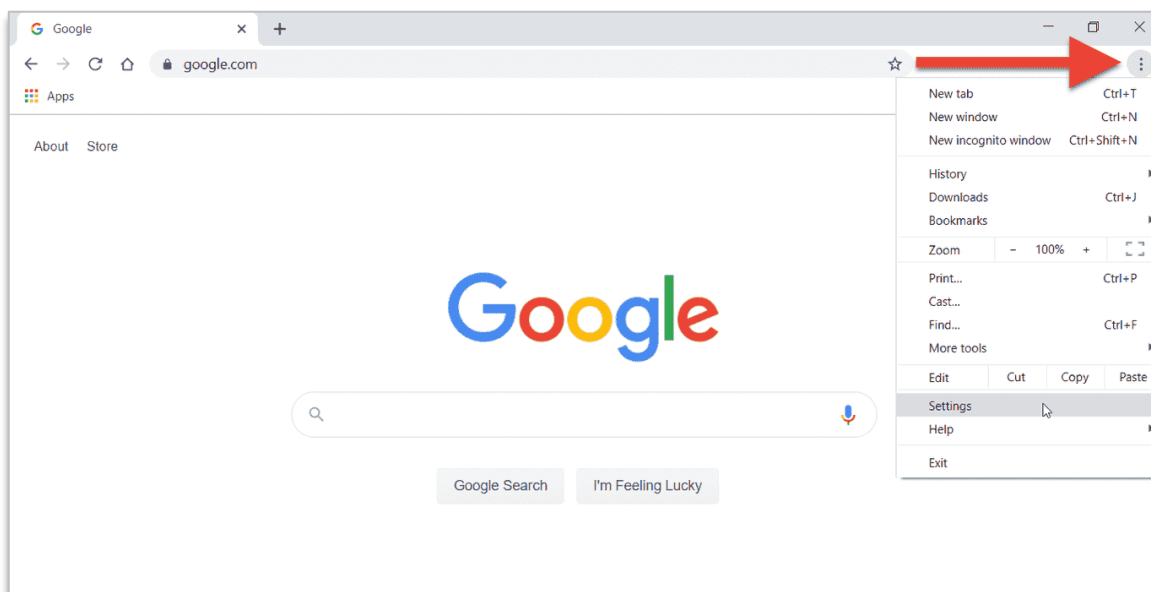

Figure 3-56 Chrome Settings

b. Expand the **Advanced** menu on left-hand side and go to **Privacy and Security**.

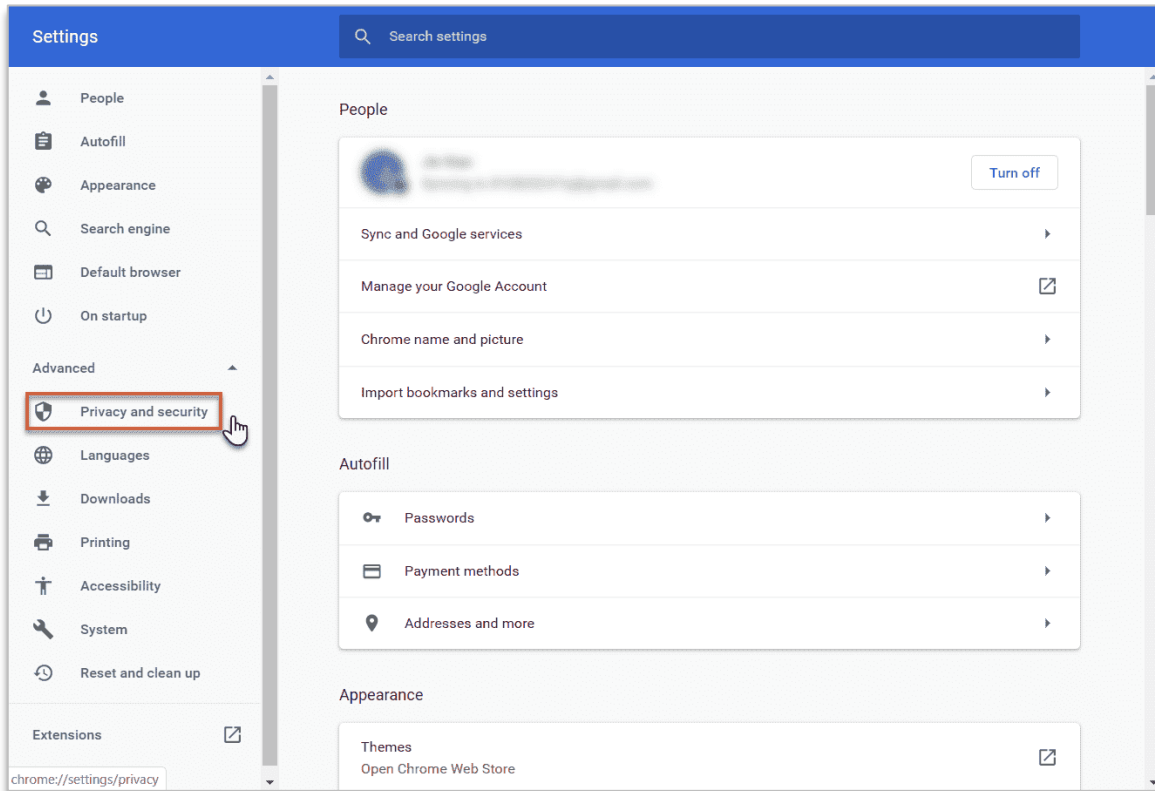

Figure 3-57 Privacy and security

c. Choose **Manage certificates** and then click on **Import** on the **Certificates** dialog box.

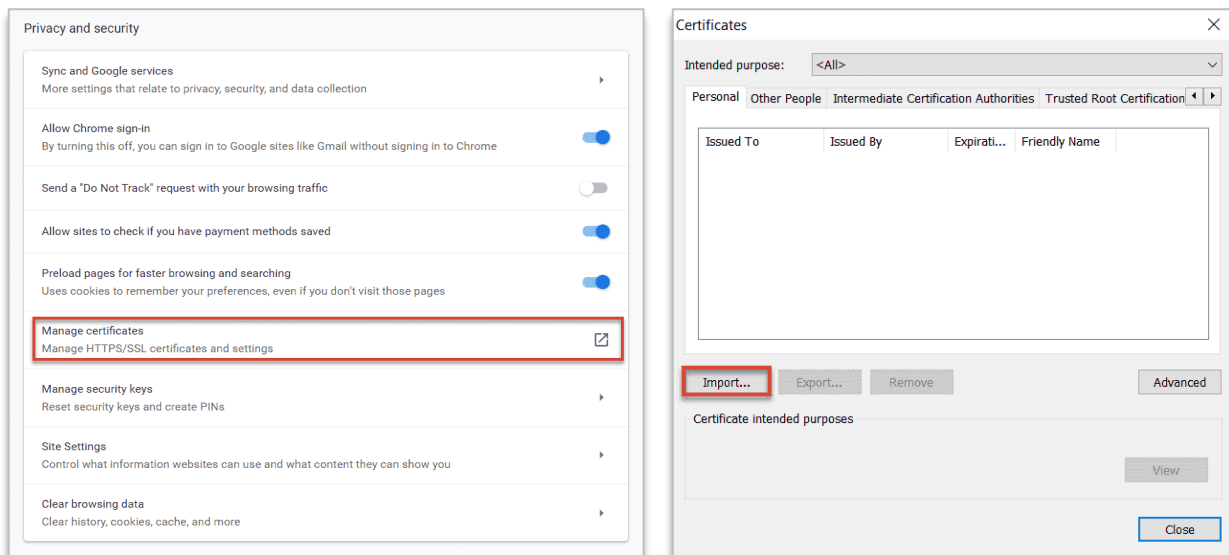

Figure 3-58 Manage certificates -> Import certificate

- d. Follow the discrete steps wizard for importing the certificate. Choose the .pfx certificate and enter the password for the **private key** which is “123456”. It’s recommended to place the certificate in **Trusted Publishers** store in the next step.

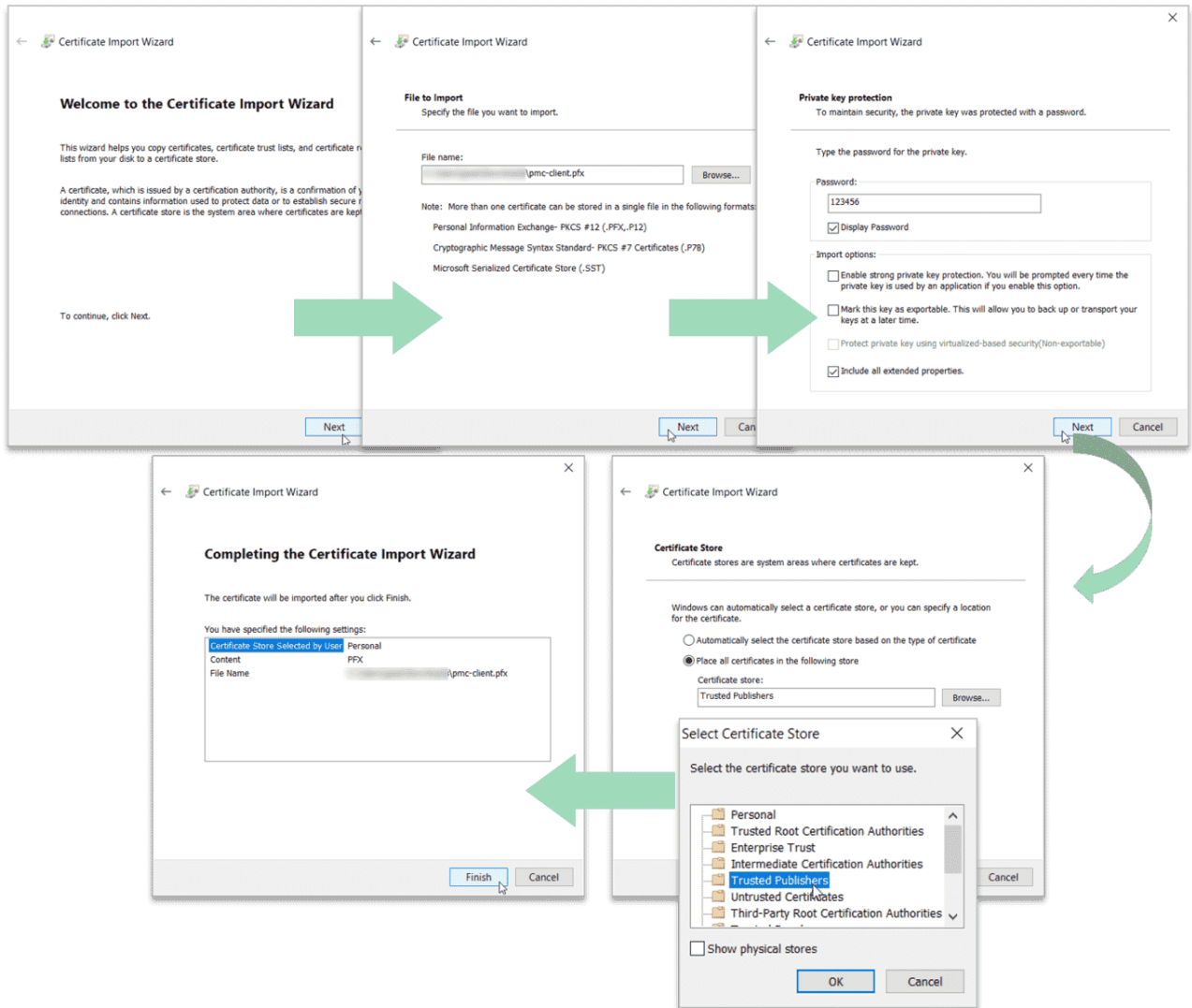

Figure 3-59 Import .pfx certificate

- 2) Restart **Chrome** and enter the complete IP address such as <https://192.168.0.100> in the address area of **Google Chrome**, and then press **<Enter>**.

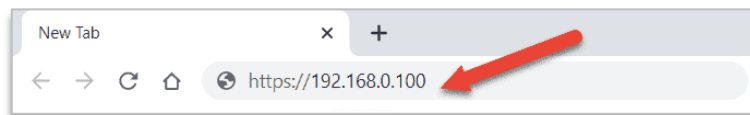

Figure 3-60 Web Logon

3) Select the **pmc-client** certificate as shown in the following figure and press **OK**.

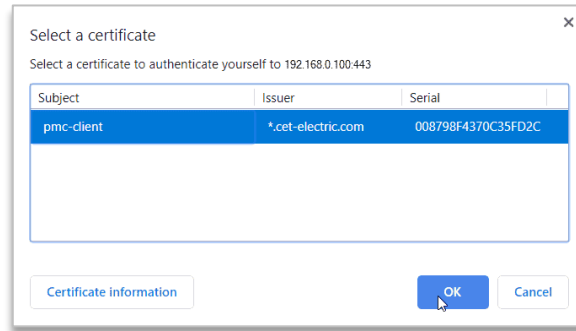

Figure 3-61 Select a certificate

4) The following Privacy Error may appear since the certificate is untrusted for **Chrome**. Click on **Advanced** then **Proceed to localhost (unsafe)**.

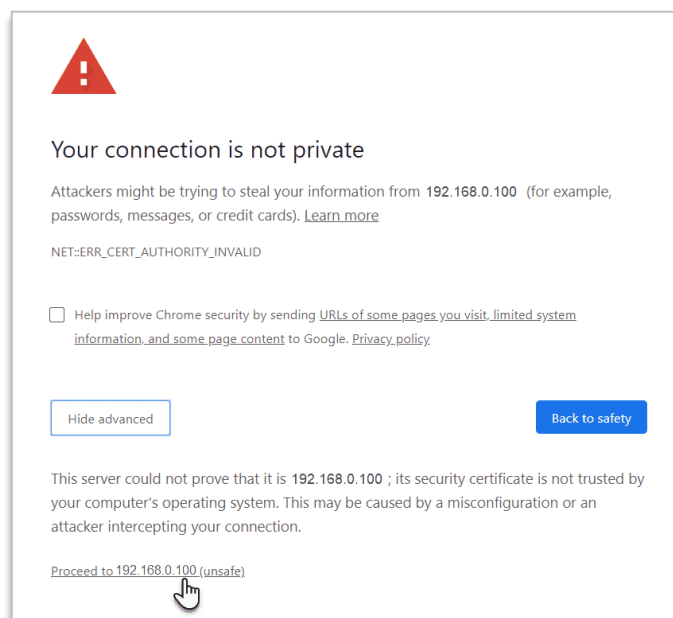

Figure 3-62 Privacy Error

5) The iMeter 7A's logon page appears.

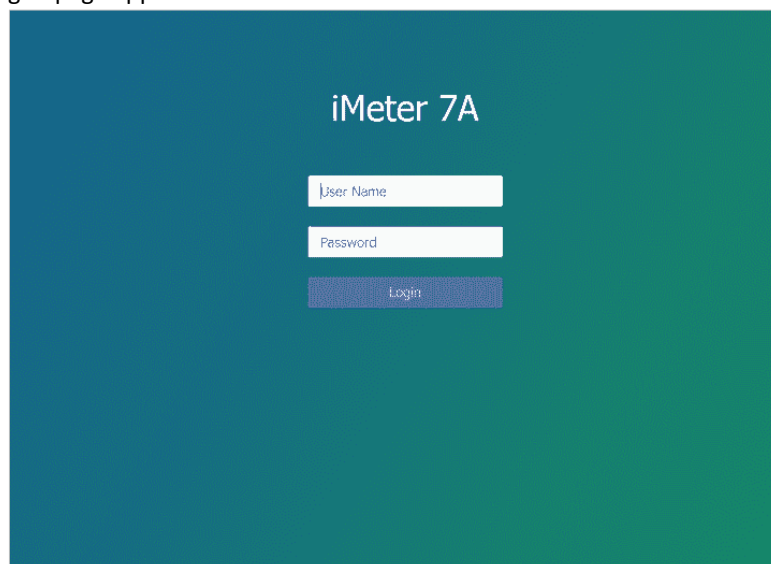

Figure 3-63 Web Interface

- 6) The user is required to login to the web interface to view data or change setup parameters. The figure below lists the different users and the corresponding authorities.

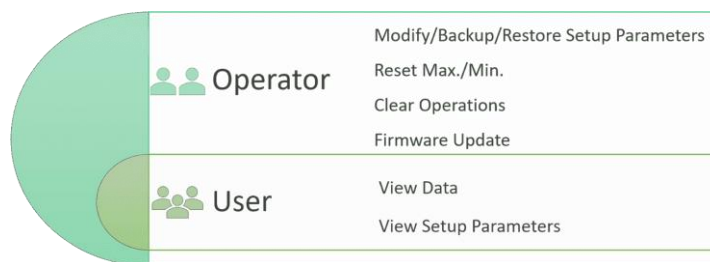

Figure 3-64 Authorities with their Permission Levels

As the figure shows, **Operator** has a higher permission than **User**. The default **Login Info.** for the operator and user accounts is listed below:

Account	Username	Password
Operator	operator	abcd1234-
User	user	abcd1234-

Table 3-4 Default Username and Password for Operator and User accounts

- 7) The iMeter 7A's Web Interface appears after login. There are six items at the **Title Bar** – **PQ Insight, Metering, Power Quality, Events, Setup** and **HMI**.

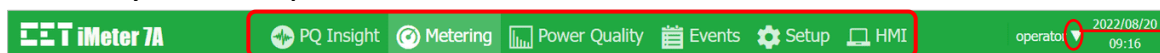

Figure 3-65 Title Bar

- 8) The Web Interface's login password can be changed by clicking on the down arrow at the upper right-hand corner of the page and then selecting **Change Password** as shown below.

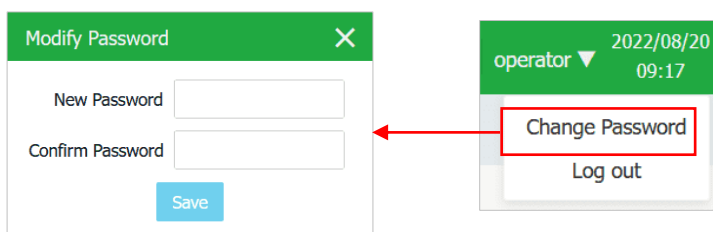
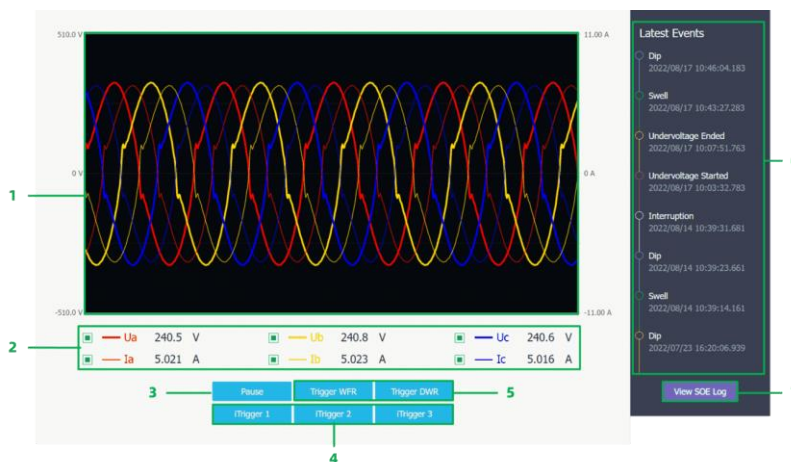

Figure 3-66 Change Web Interface Password

3.2.3.1 PQ Insight

Click **PQ Insight** menu and the **Real-time Waveform** is displayed which includes the following information and operations:



- | | | | |
|---|--|---|-----------------------------------|
| 1 | Voltage & Current Waveforms | 5 | Manual Trigger WFR/DWR |
| 2 | Select/De-select Voltage/Current Channels | 6 | Latest 8 Events in SOE Log |
| 3 | Toggle between <Pause> & <Refresh> for waveform update | 7 | Enter SOE Log |
| 4 | Manual Trigger iTrigger 1/2/3 | | |

Figure 3-67 PQ Insight

3.2.3.2 Metering

Click **Metering** at the **Title Bar** and its sub-menus appear on the left-hand pane which includes **Phasor**, **RMS**, **Fundamental**, **Energy**, **Demand**, **TOU**, **Max./Min.** and **I/O**. The following sections provide an overview of this sub-menus.

3.2.3.2.1 Phasor

Click **Phasor** on the left-hand pane and the following screen appears which displays the Magnitude and Phase information for Ua/Ub/Uc (3P4W) or Uab/Ubc/Uca (3P3W) and Ia/Ib/Ic as well as Frequency. Click **Export** to save the Phasor data to a .csv file at the default Download folder for the Web Browser.

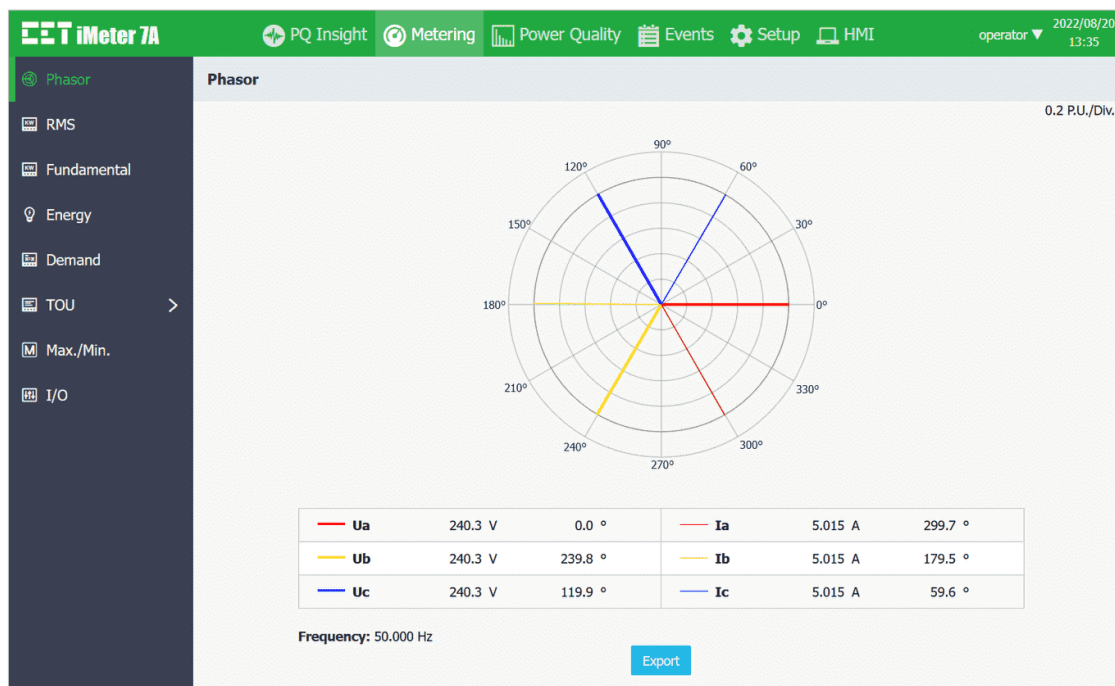

Figure 3-68 Phasor Diagram

3.2.3.2.2 RMS

Click **RMS** on the left-hand pane and the following screen appears which shows the real-time RMS readings for 3- Φ Voltages, Currents, Powers and Power Factors as well as U4, Ung, I4, OT (Operating Time), Frequency and IR. Click **Export** to save the data on this page to .csv file at the default Download folder.

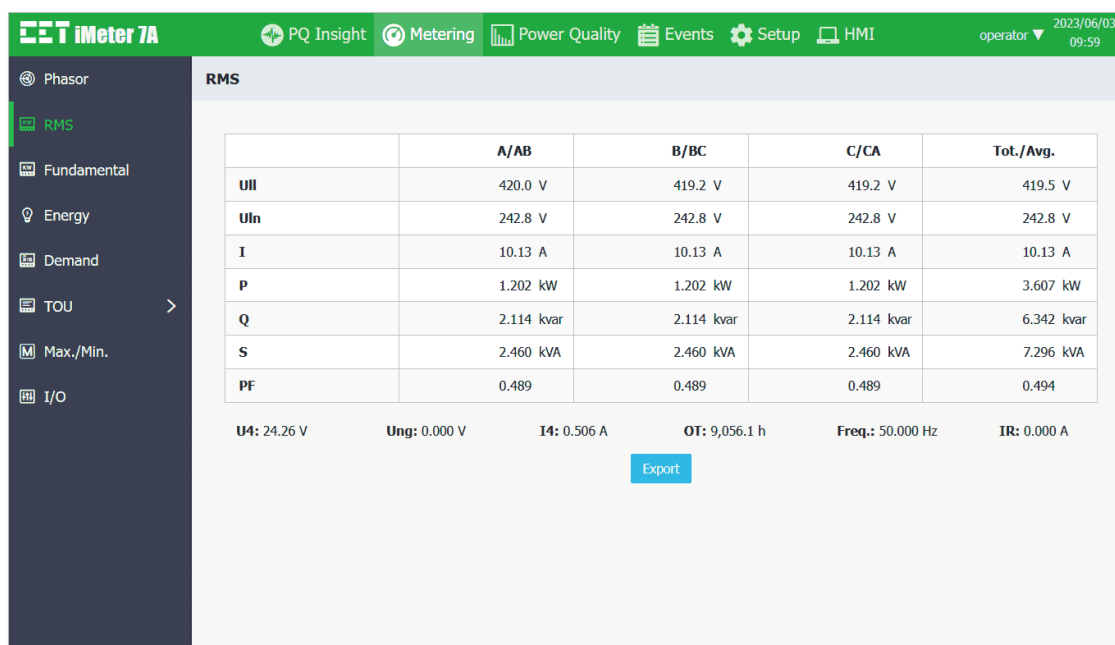

Figure 3-69 RMS Metering

3.2.3.2.3 Fundamental

Click **Fundamental** on the left-hand pane and the following screen appears which shows the fundamental readings for 3- Φ Voltages, Currents, Power, Power Factor, U4 and I4. Click **Export** to save the data on this page to .csv file at the default Download folder.

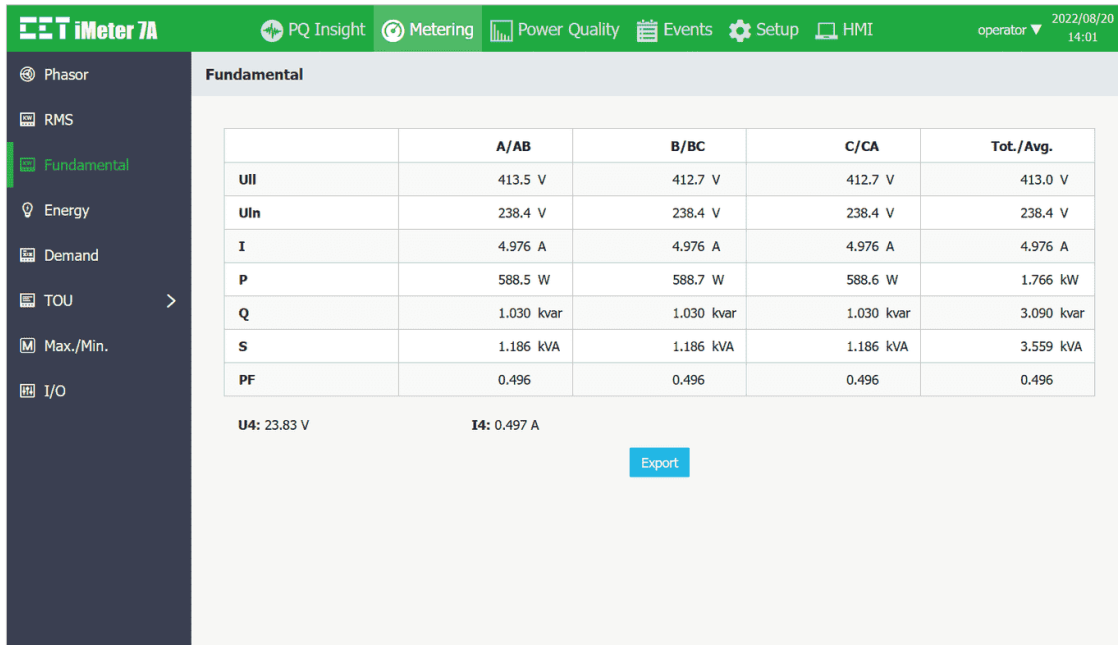

Figure 3-70 Fundamental Metering

3.2.3.2.4 Energy

Click **Energy** on the left-hand pane and the following screen appears which shows the **RMS, Fundamental and Harmonic kWh/kvarh for Import/Export/Net/Total** as well as the **Total Apparent** Energy for the total of 3 phases.

Click **Active** or **Reactive** from the drop-down list to switch between Active/Reactive Energy display.

Click **Export** to save all the Energy information to a .csv file at the default Download folder.

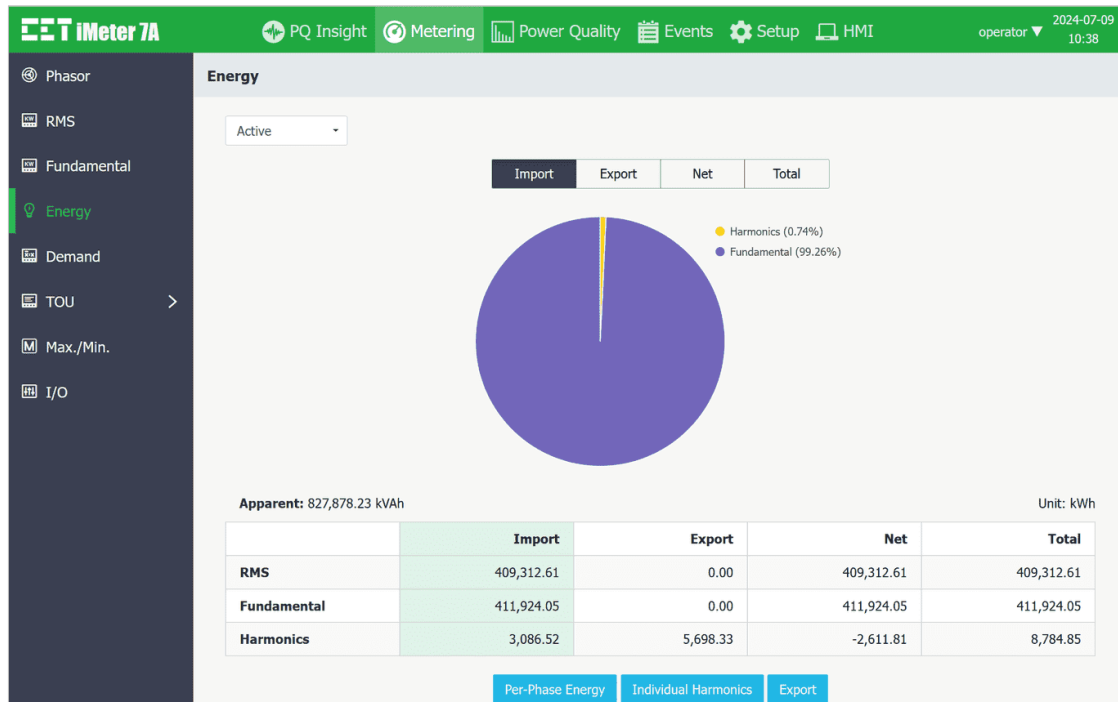

Figure 3-71 Energy Interface

Click **Per-phase Energy** and the per-phase kWh, kvarh Import/Export/Net/Total and kVAh measurements are available.

Per-Phase Energy				
	A	B	C	
	Import	Export	Net	Total
kWh	464,945.80	0.00	464,945.80	464,945.80
kvarh	812,873.79	0.00	812,873.79	812,873.79
kVAh	--	--	--	947,153.28

Figure 3-72 Per-phase Energy

Click **Individual Harmonics** and the following pages are available which display the Harmonic Energy in spectrum or table format for kWh, kvarh Import/Export by selecting Spectrum or Table from the top left drop-down list.

- Spectrum** Move the mouse pointer over a particular histogram to show its harmonic order and value. Click on the **kWh Imp.**, **kWh Exp.**, **kvarh Imp.**, **kvarh Exp.** tab at the top to view the respective Harmonic Energy spectrum.

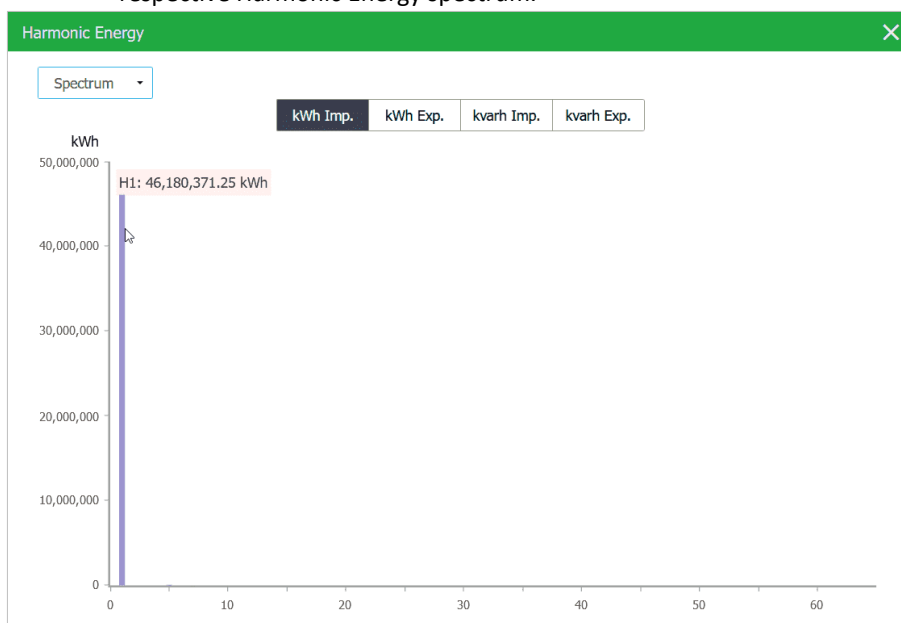

Figure 3-73 Individual Harmonics Spectrum

Table

Harmonic Energy				
	Table			
Order	kWh Imp. (kWh)	kWh Exp. (kWh)	kvarh Imp. (kvarh)	kvarh Exp. (kvarh)
01	46,180,371.28	0.00	80,814,991.06	0.00
02	0.00	4,711.36	8,022.98	0.00
03	0.00	379,357.84	0.00	4,182.22
04	0.00	1,124.41	0.00	2,016.21
05	75,746.92	0.00	0.00	125,798.59
06	617.43	0.00	13.64	0.00
07	33,910.76	0.00	62,376.20	0.00
08	0.00	319.15	517.39	0.00
09	0.00	43,061.53	0.00	1,423.21
10	0.00	279.10	0.00	527.12

Figure 3-74 Individual Harmonics Table

3.2.3.2.5 Demand

Click **Demand** on the left-hand pane and the following screen appears which shows the readings for **Demand (Present Demand)**, **Predicted (Predicted Demand)**, **This Max.** and **Last Max.** Depending on the setting of the **Self-Read Time**, **This Max.** and **Last Max.** could mean the Max. Demand of This Month / Last Month or Since / Before Last Reset.

Move the mouse pointer over the readings for **This Max.** and **Last Max.** to show the corresponding timestamp.

Click **Export** to save the **Demand** data on this page to .csv file at the default Download folder.

Click **Reset This Max.** (only accessible for **Operator**) to manually reset the Max. Demand of This Month or Since Last Reset. It should be noted that it's not possible to manually reset the **Last Max.**, which is the Max. Demand of Last Month or Before Last Reset.

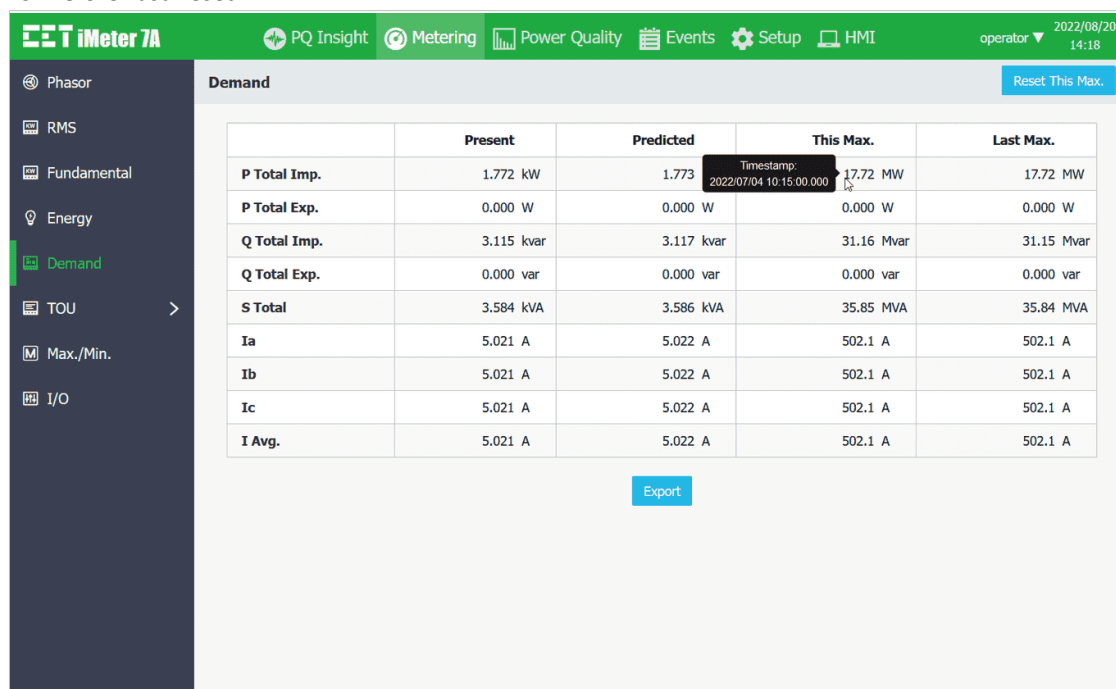

Figure 3-75 Demand Interface

3.2.3.2.6 TOU

Click **TOU** on the left-hand pane to view the **Real Time**, **Freeze Record** and **Historical Record** TOU information.

3.2.3.2.6.1 Real Time

The page displays the present TOU information, including Energy and Max. Demand for all 8 Tariffs. The **Present Schedule**, **Present Tariff**, **Present Season** and **Present Daily Profile** are displayed at the top of the page. Click **Switch Schedule** to manually switch between Schedule for TOU1 and TOU2.

- Energy** Select from the drop-down list underneath Present Tariff to display the respective Tariff information for **kWh Imp.**, **kWh Exp.**, **kvarh Imp.**, **kvarh Exp.** and **kVAh**.

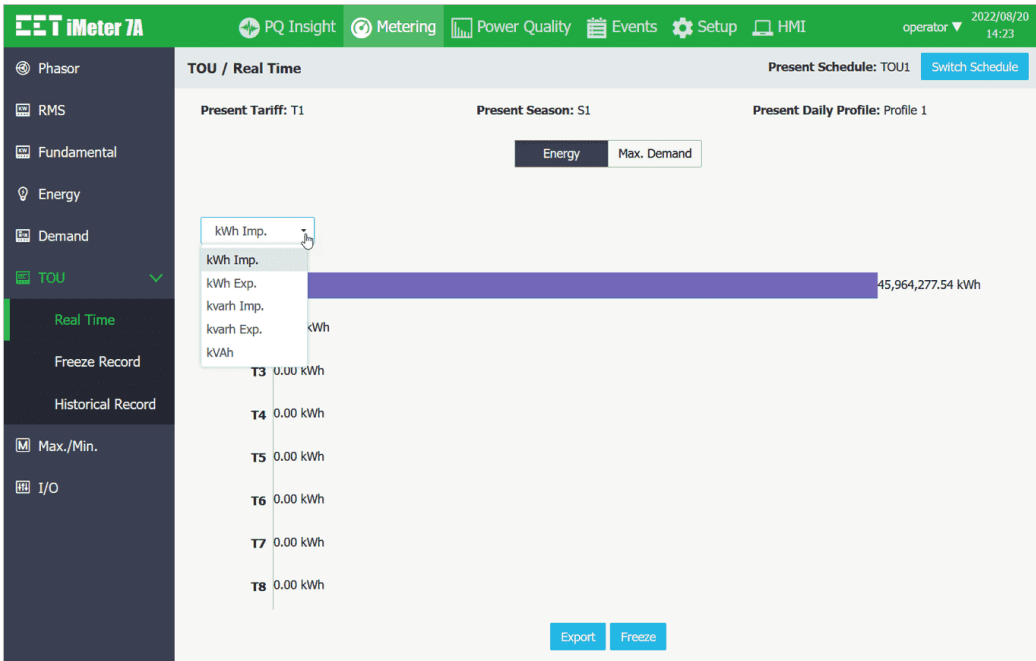

Figure 3-76 Real Time TOU Energy

- Max. Demand** Select from the drop-down list underneath Present Tariff to display the respective Tariff information for **P Imp.**, **P Exp.**, **Q Imp.** and **Q Exp.**.

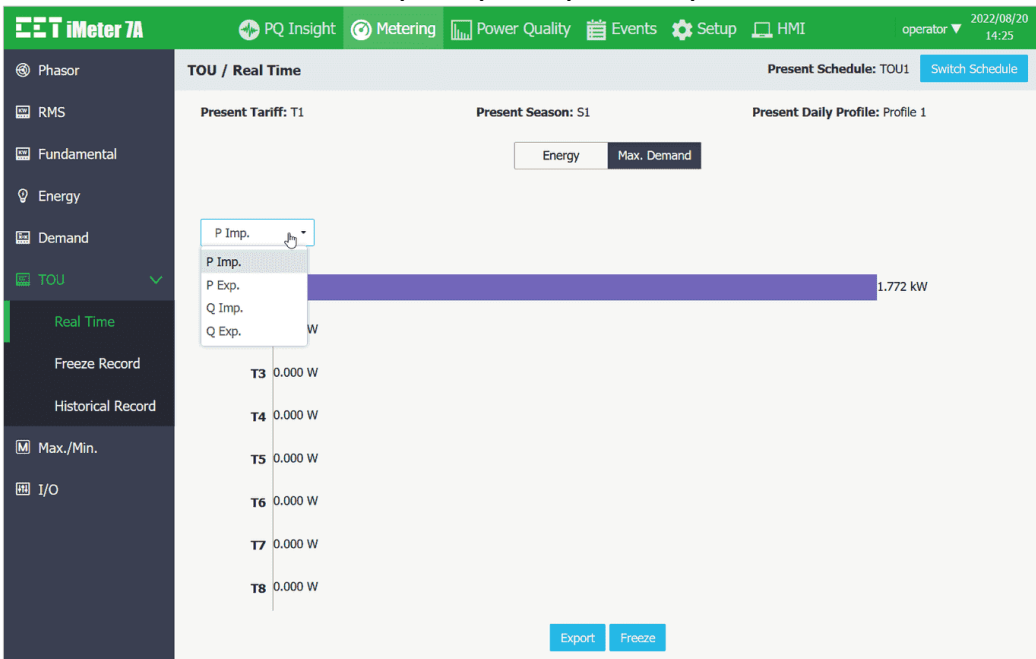

Figure 3-77 Real Time TOU Max. Demand

Click **Export** to save the **Real Time TOU** data to a .csv file at the default Download folder. Click **Freeze** to take a momentary snapshot of the TOU Energy and Max. Demand.

3.2.3.2.6.2 Freeze Record

The iMeter 7A provides a **Freeze Record** with timestamp for the Energy and Max. Demand generated momentarily after the manual **Freeze** operation from the **TOU > Real Time** interface.

Click **Export** to save the **Freeze Record** data to a .csv file at the default Download folder.

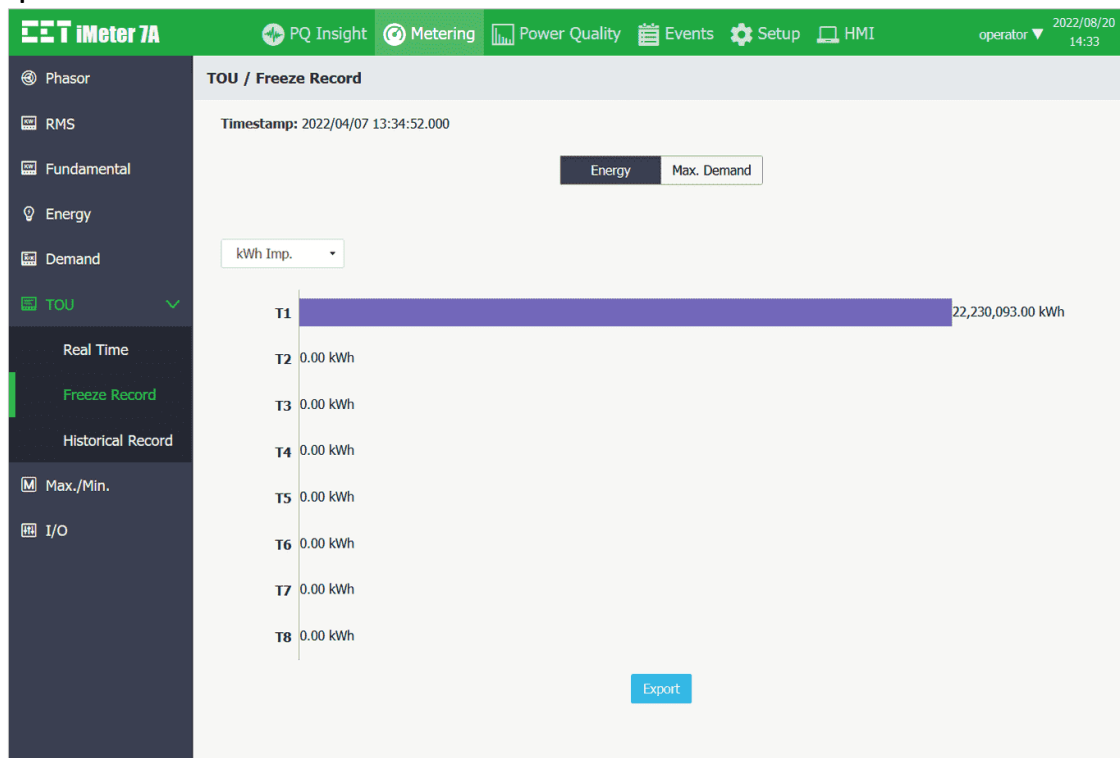

Figure 3-78 TOU Freeze Record

3.2.3.2.6.3 Historical Record

The iMeter 7A can restore up to 12 Historical Records with timestamps based on the First-In-First-Out principle. The **Historical Record** includes PF Total, TOU Energy and Max. Demand for the 8 Tariffs. When the **TOU Record Self-Read Time** is set to **Auto**, the **Historical Record** is generated monthly at the pre-defined **Self-Read Time**. It can also be manually generated by clicking on the **Trigger TOU Recording** button at the top right. Click **Export** to save the currently displayed **Historical Record** data to a .csv file at the default Download folder.

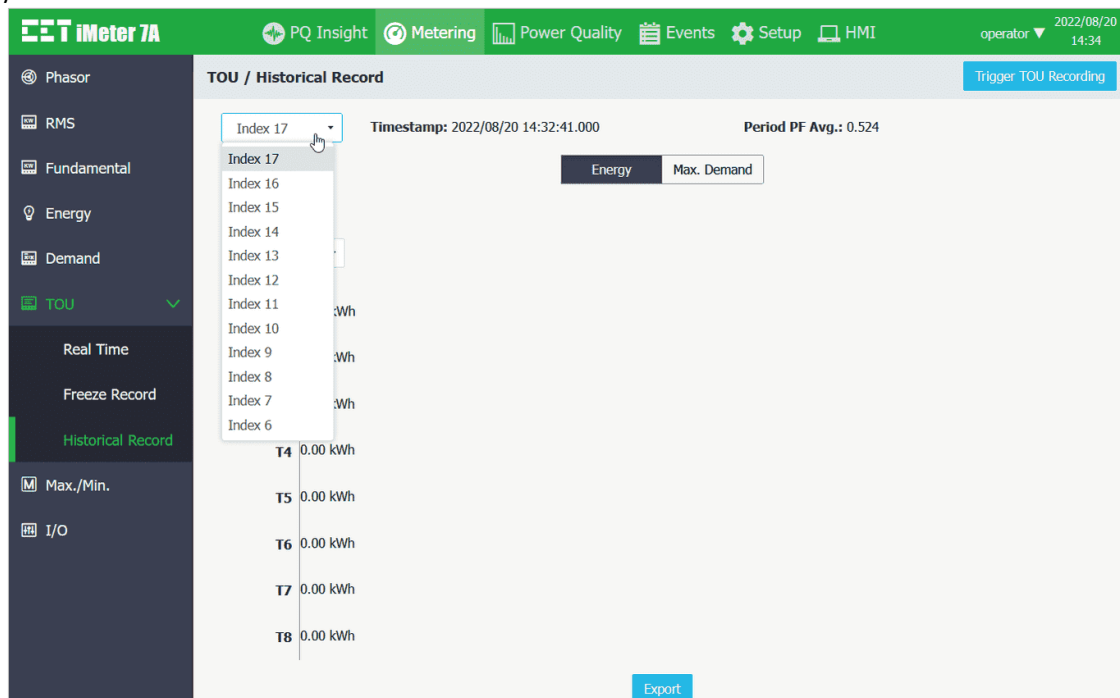

Figure 3-79 TOU – Historical Record

3.2.3.2.7 Max./Min.

Click **Max./Min.** on the left-hand pane and the following screen appears which displays the 4 Max./Min. Recorders. Move the mouse pointer over the readings for **This Max.** and **Last Max.** to show the corresponding timestamp. Click **Export** to save the specific group of **Max.** or **Min.** data displayed on the current page to a .csv file at the default Download folder.

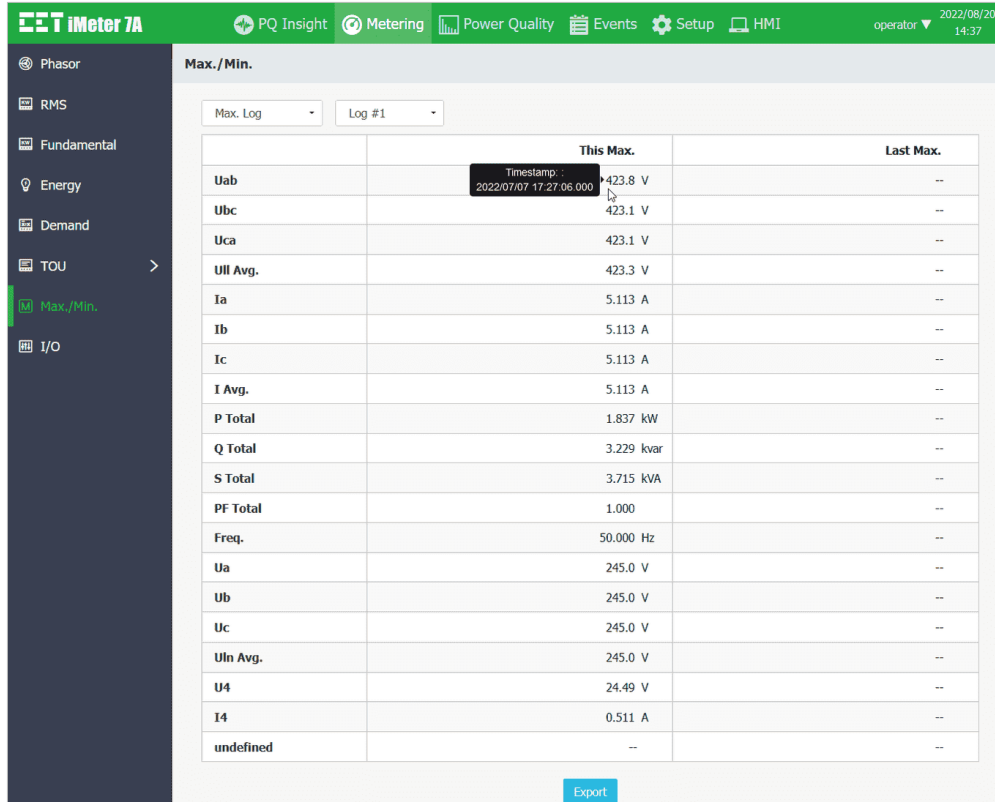

Figure 3-80 Max./Min. Interface

3.2.3.2.8 I/O

Click **I/O** on the left-hand pane and the following screen appears which displays the I/O function and status.

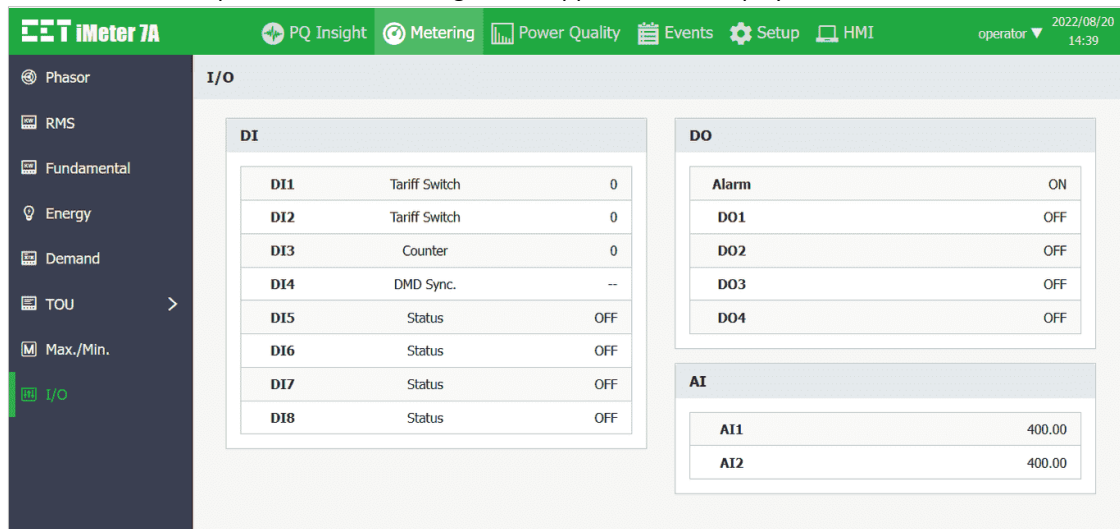

Figure 3-81 I/O Interface

3.2.3.3 Power Quality

Click **Power Quality** at the **Title Bar** and its sub-menus appear on the left-hand pane which includes **Harmonics**, **Interharmonics**, **2kHz - 150kHz C.E.**, **Deviation**, **Unb. & Seq.**, **Flicker** and **EN50160**. The following sections provide a quick overview of these web pages.

3.2.3.3.1 Harmonics

Click **Harmonics** on the left-hand pane and the following screen appears which displays the Spectrum for up to 63rd harmonics and the following parameters: **THD**, **TOHD**, **TEHD**, **Crest Factor**, **K-Factor**, **TDD**, **TDD Odd** and **TDD Even**.

Click **Ua**, **Ub**, **Uc**, **U4**, **Ia**, **Ib**, **Ic** or **I4** at the top of the page to view the respective Harmonics data. Move the mouse pointer over a particular histogram to show its harmonic order and value.

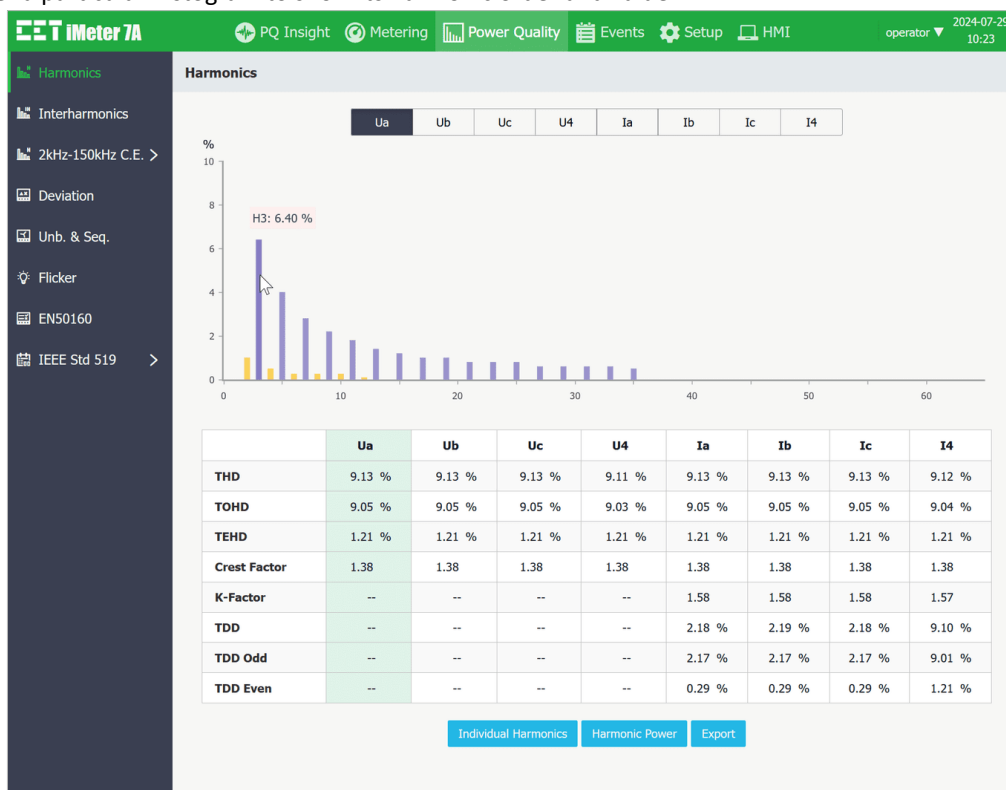

Figure 3-82 Harmonics Interface

- Click **Individual Harmonics** at the bottom of the page to view the **%HD**, **RMS** and **Angle** for 4- Φ Voltages and Currents in a Table format.

The screenshot shows a window titled 'Individual Harmonics' containing a table with columns for harmonic order, %HD, RMS, and Angle. The table lists data for harmonics 01 through 14.

	%HD	RMS	Angle
01	100.00 %	57.80 V	0.0 °
02	1.00 %	0.576 V	60.0 °
03	6.40 %	3.698 V	60.0 °
04	0.50 %	0.289 V	60.0 °
05	4.00 %	2.311 V	60.0 °
06	0.26 %	0.150 V	59.9 °
07	2.80 %	1.617 V	60.0 °
08	0.26 %	0.151 V	60.0 °
09	2.20 %	1.271 V	60.1 °
10	0.26 %	0.150 V	59.9 °
11	1.80 %	1.039 V	60.0 °
12	0.10 %	0.058 V	0.0 °
13	1.40 %	0.809 V	60.0 °
14	0.00 %	0.000 V	0.0 °

Figure 3-83 Harmonics – Individual Harmonics

- Click **Harmonic Power** at the bottom of the page to display the individual harmonic measurements for 3- Φ P, Q, S and PF in Table format.

	P	Q	S	PF
Total	-0.688 W	-0.042 var	0.689 VA	-0.998
01	27.90 W	50.30 var	57.52 VA	0.485
02	-0.003 W	0.005 var	0.006 VA	-0.504
03	-0.235 W	-0.001 var	0.235 VA	-1.000
04	0.000 W	0.000 var	0.000 VA	0.581
05	0.047 W	-0.079 var	0.092 VA	0.509
06	0.000 W	0.000 var	0.000 VA	0.500
07	0.022 W	0.039 var	0.045 VA	0.488
08	0.000 W	0.000 var	0.000 VA	0.499
09	-0.028 W	-0.001 var	0.028 VA	-1.000
10	0.000 W	0.000 var	0.000 VA	0.503
11	0.010 W	-0.016 var	0.019 VA	0.520
12	0.000 W	0.000 var	0.000 VA	1.000

Figure 3-84 Harmonic Power

Click **Export** to export all the harmonic data to a .csv file at the default Download folder.

3.2.3.3.2 Interharmonics

Click **Interharmonics** on the left-hand pane and the following screen appears which displays the Spectrum for up to 63rd Interharmonics and **TIHD**, **TOIHD** and **TEIHD** for 4- Φ Voltages and Currents. Move the mouse pointer over a particular histogram to show its Interharmonic order and value.

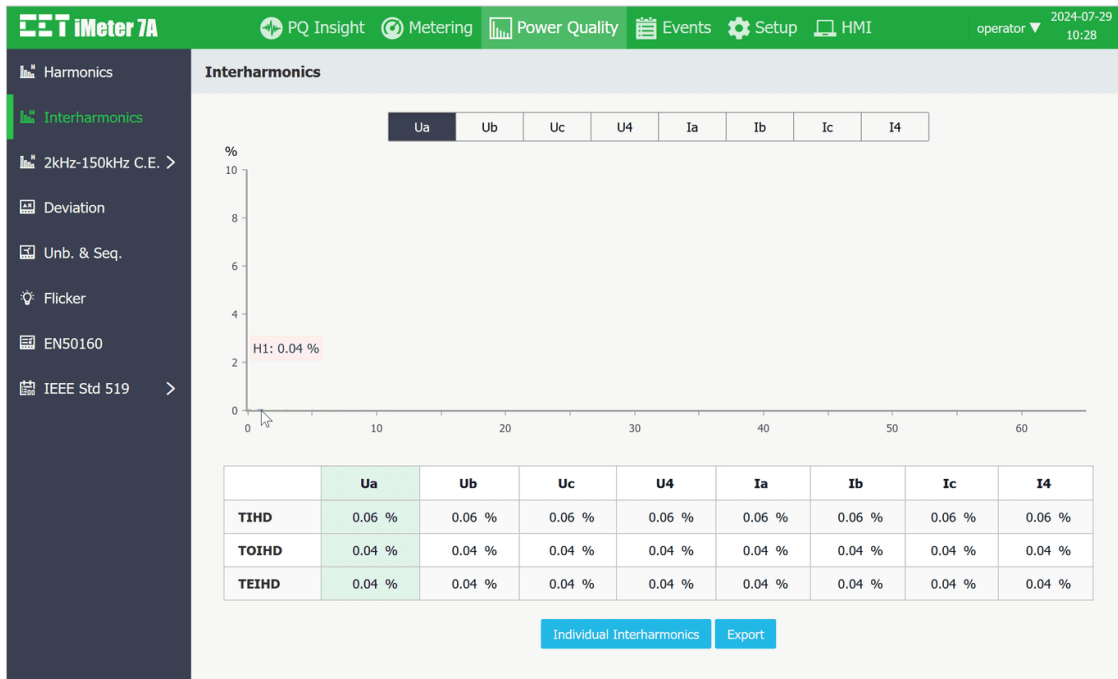

Figure 3-85 Interharmonics Interface

Click **Individual Interharmonics** at the bottom of the page to view the **%IHD** and **RMS** for 4- Φ Voltages and Currents in a Table format.

Order	%IHD	RMS
00	0.04 %	0.100 V
01	0.03 %	0.072 V
02	0.01 %	0.034 V
03	0.01 %	0.015 V
04	0.01 %	0.015 V
05	0.00 %	0.009 V
06	0.00 %	0.009 V
07	0.00 %	0.009 V
08	0.00 %	0.005 V
09	0.00 %	0.007 V
10	0.00 %	0.006 V
11	0.00 %	0.004 V
12	0.00 %	0.005 V
13	0.00 %	0.005 V
14	0.00 %	0.003 V
15	0.00 %	0.005 V

Figure 3-86 Individual Interharmonics

Click **Export** to export all the Interharmonic data to a .csv file at the default Download folder.

3.2.3.3.3 2kHz - 150kHz C.E.

Click **2kHz - 150kHz C.E.** on the left-hand pane to view the **Real Time, Daily Heat Map** information.

3.2.3.3.3.1 Real Time

This page displays the U_{rms} C.E. in the frequency band of 2kHz - 9kHz and 9kHz - 150kHz as well as I_{rms} C.E. in the frequency band of 2kHz - 9kHz with a resolution @ 3s.

Index	Segment	Ua	Ub	Uc
1	2.1 kHz	0.000 V	0.000 V	0.000 V
2	2.3 kHz	0.000 V	0.000 V	0.000 V
3	2.5 kHz	0.000 V	0.000 V	0.000 V
4	2.7 kHz	0.000 V	0.000 V	0.000 V
5	2.9 kHz	0.000 V	0.000 V	0.000 V
6	3.1 kHz	0.000 V	0.000 V	0.000 V
7	3.3 kHz	0.000 V	0.000 V	0.000 V
8	3.5 kHz	0.000 V	0.000 V	0.000 V
9	3.7 kHz	0.000 V	0.000 V	0.000 V
10	3.9 kHz	0.000 V	0.000 V	0.000 V

Figure 3-87 Real Time U_{rms} 2kHz - 9kHz C.E.

3.2.3.3.2 Daily Heat Map

This page displays the Daily Heat Map and the 3-Φ Peak values for the Max./Min./Average/CP95 of U_{rms}/I_{rms} with timestamp in a specific day.

Click **Export** to save the currently displayed Peak values and 24-hour C.E. with an interval of 1-minute to a .csv file at the default download folder.

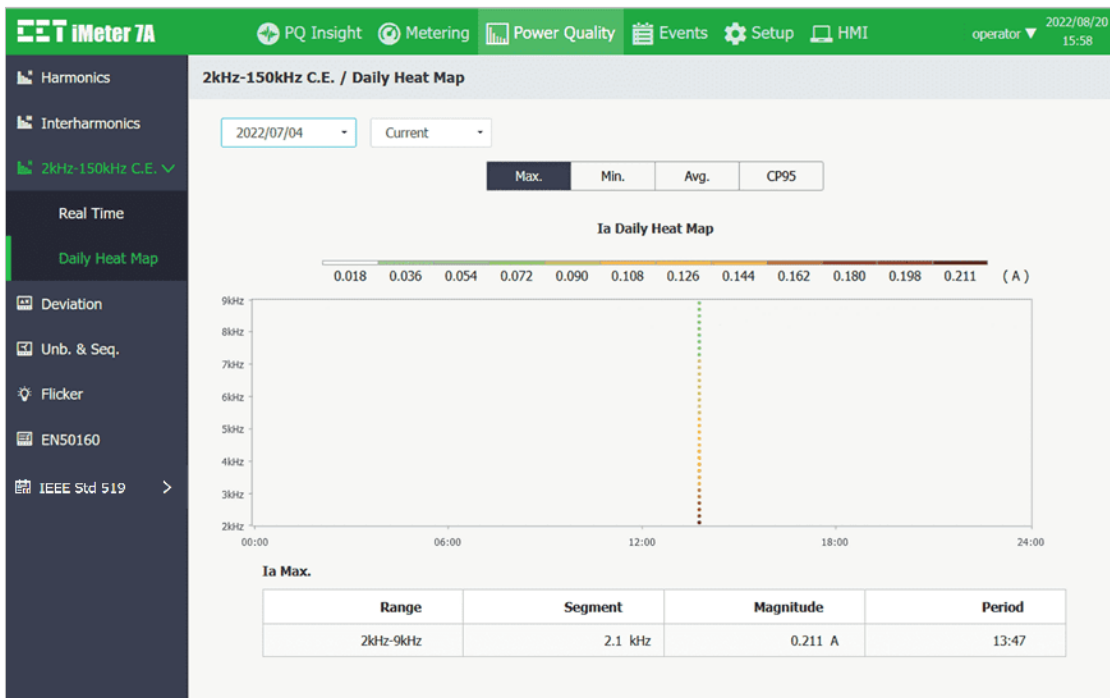

Figure 3-88 Daily Heat Map – Peak value for Ia Max.

3.2.3.3.4 Deviation

Click **Deviation** on the left-hand pane to display the **Over/Under Deviation** measurements for 3-Φ UIn and Ull as well as Frequency Deviation.

Click **Export** to save the data to a .csv file at the default Download folder.

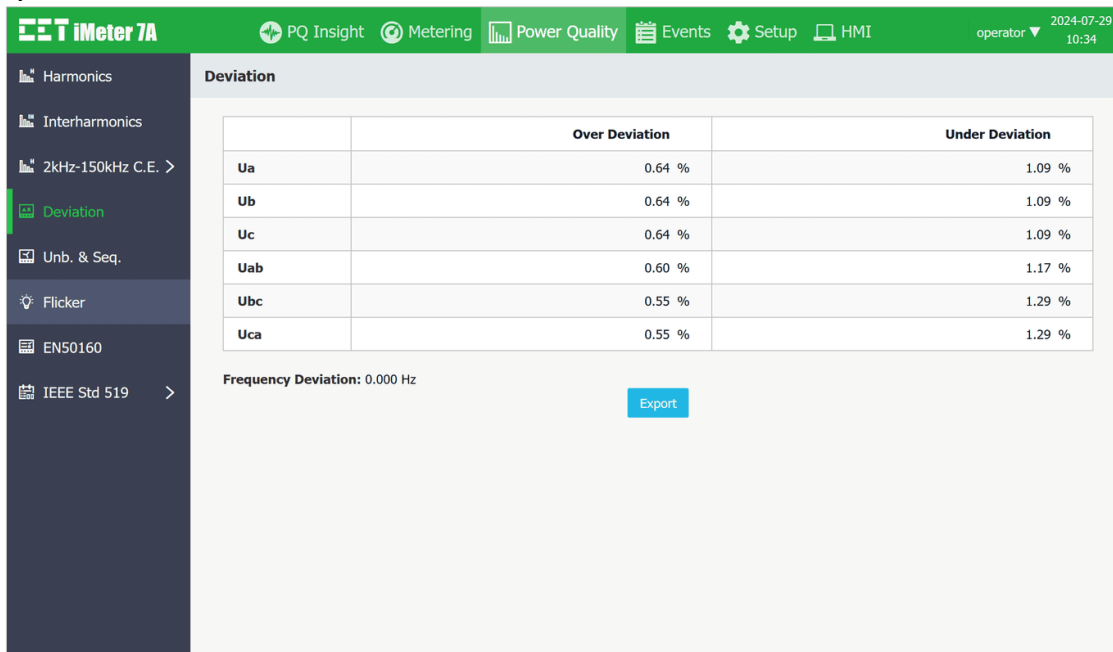

Figure 3-89 Deviation Interface

3.2.3.3.5 Unb. & Seq.

Click **Unb. & Seq.** on the left-hand pane to display the Negative and Zero Sequence Unbalance as well as the Positive, Negative and Zero Sequence measurements for Voltage and Current.

Click **Export** to save the data to a .csv file at the default Download Folder.

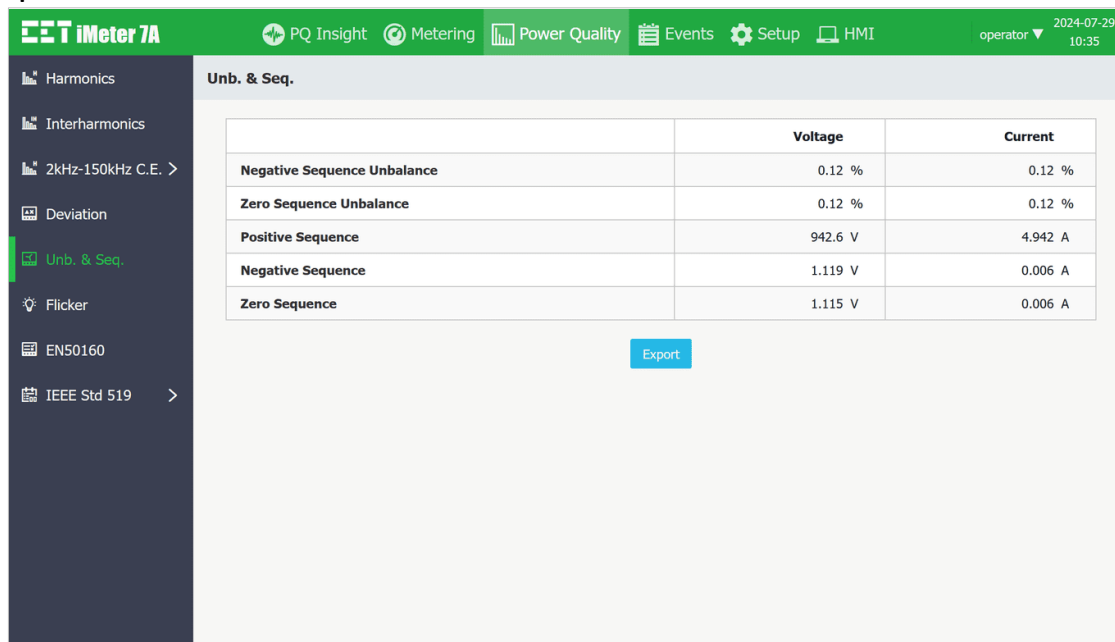

Figure 3-90 Unb. & Seq. Interface

3.2.3.3.6 Flicker

Click **Flicker** on the left-hand pane to display the **Pst/PIt** measurements for 3- Φ Voltages. Click **Export** to save the data to a .csv file at the default Download Folder.

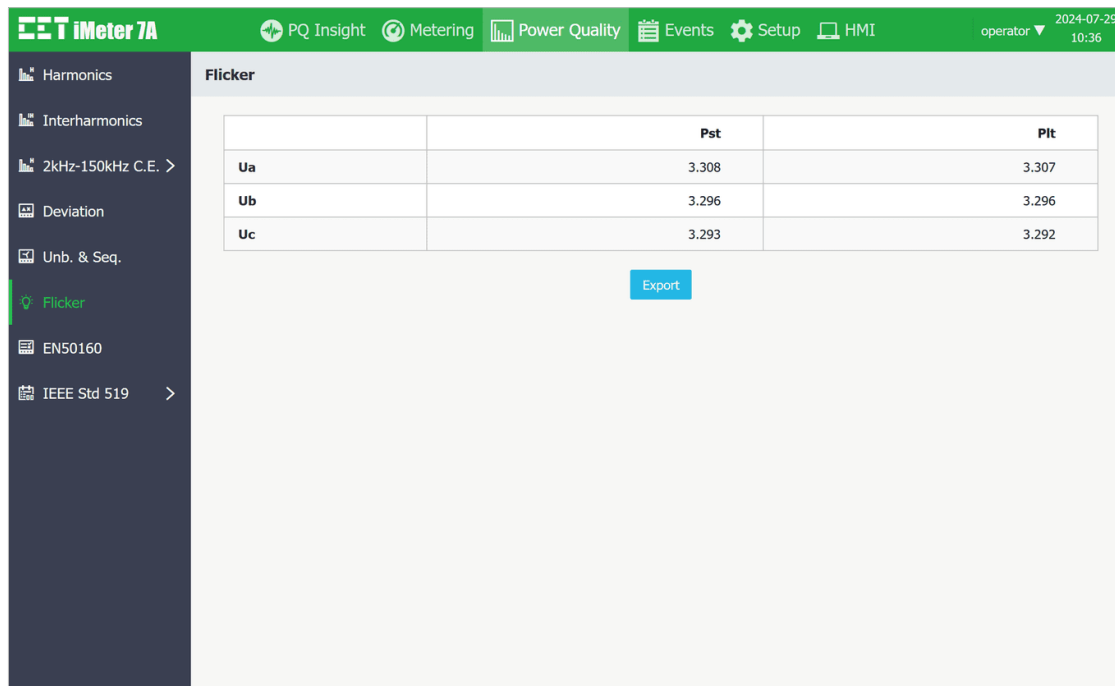

Figure 3-91 Flicker Interface

3.2.3.3.7 EN 50160

Click **EN50160** on the left-hand pane and the following screen appears. Click on the drop-down list on the top left to select the period for the desired EN 50160 Summary Report. As shown in Figure 3-92, ✓ denotes the positive evaluation while ✗ denotes the negative evaluation for the parameter. Click on a particular parameter to view the report details. Click **Export** to download the EN50160Report_WeekXX.xls file for the currently selected period.

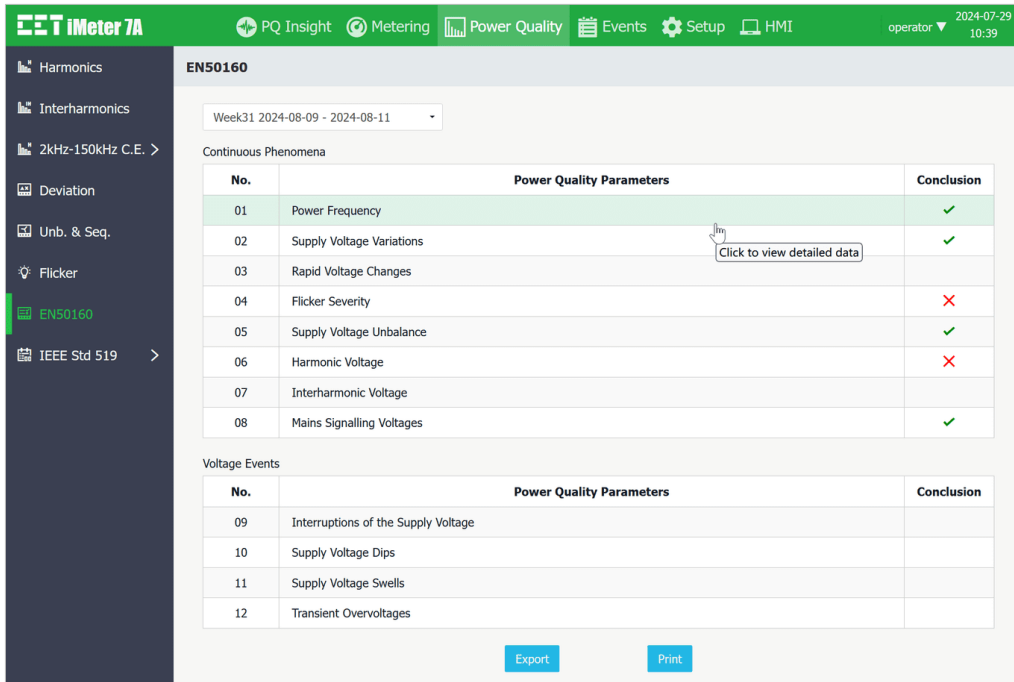

Figure 3-92 EN 50160 Summary Report

The following screenshots provide a quick overview of the summary details for each parameter.

- **Power Frequency**

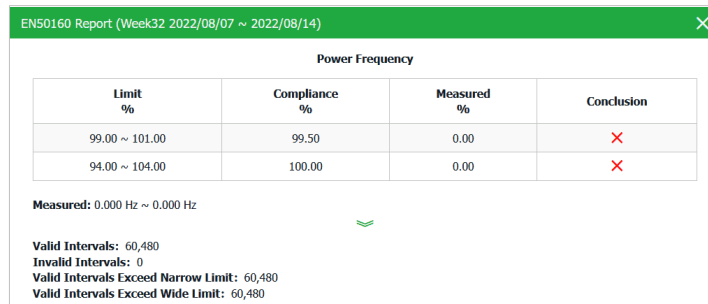

Figure 3-93 Power Frequency

- **Supply Voltage Variations**

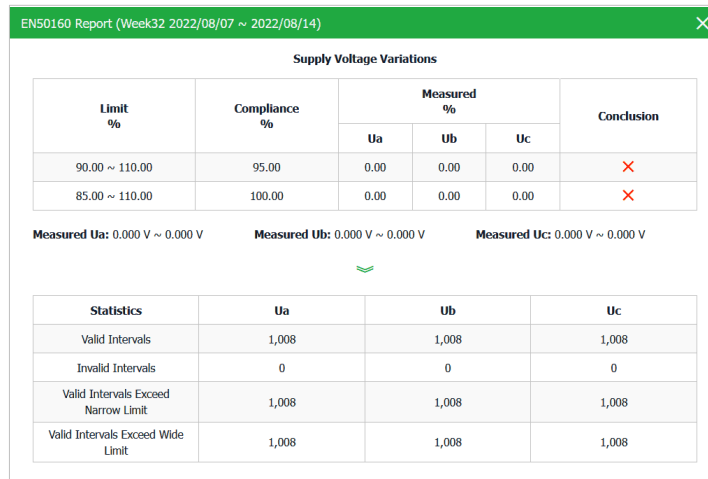

Figure 3-94 Supply Voltage Variations

• Rapid Voltage Changes

Rapid Voltage Changes		
Ua Count	Ub Count	Uc Count
0	0	0

Figure 3-95 Rapid Voltage Changes

• Flicker Severity

Limit	Compliance %	Measured %			Conclusion
		Ua	Ub	Uc	
PIt ≤ 1.000	95.00	100.00	100.00	100.00	✓

Measured Ua PIt: 0.000 ~ 0.000 Measured Ub PIt: 0.000 ~ 0.000 Measured Uc PIt: 0.000 ~ 0.000

Statistics	Ua PIt	Ub PIt	Uc PIt
Valid Intervals	84	84	84
Invalid Intervals	0	0	0
Valid Intervals Exceed Compliance	0	0	0
CP95	0.000	0.000	0.000

Figure 3-96 Flicker Severity

• Supply Voltage Unbalance

Limit %	Compliance %	Measured %	Conclusion
2.00	95.00	100.00	✓

Measured U2 Unbalance: 0.00 % ~ 0.00 %

Valid Intervals: 1,008
Invalid Intervals: 0
Valid Intervals Exceed Compliance: 0
CP95: 0.00 %

Figure 3-97 Supply Voltage Unbalance

• Harmonic Voltage

Order h	Limit %	CP95 %			Compliance %	Measured %			Conclusion
		Ua	Ub	Uc		Ua	Ub	Uc	
THD	8.00	0.00	0.00	0.00	95.00	100.00	100.00	100.00	✓
Odd Harmonics (Not Multiples of 3)									
H05	6.00	0.00	0.00	0.00	95.00	100.00	100.00	100.00	✓
H07	5.00	0.00	0.00	0.00	95.00	100.00	100.00	100.00	✓
H11	3.50	0.00	0.00	0.00	95.00	100.00	100.00	100.00	✓
H13	3.00	0.00	0.00	0.00	95.00	100.00	100.00	100.00	✓
H17	2.00	0.00	0.00	0.00	95.00	100.00	100.00	100.00	✓
H19	1.50	0.00	0.00	0.00	95.00	100.00	100.00	100.00	✓
H23	1.50	0.00	0.00	0.00	95.00	100.00	100.00	100.00	✓
H25	1.50	0.00	0.00	0.00	95.00	100.00	100.00	100.00	✓
Odd Harmonics (Multiples of 3)									
H03	5.00	0.00	0.00	0.00	95.00	100.00	100.00	100.00	✓
H09	1.50	0.00	0.00	0.00	95.00	100.00	100.00	100.00	✓
H15	0.50	0.00	0.00	0.00	95.00	100.00	100.00	100.00	✓
H21	0.50	0.00	0.00	0.00	95.00	100.00	100.00	100.00	✓

Figure 3-98 Harmonic Voltage

• Interharmonic Voltage

EN50160 Report (Week32 2022/08/07 ~ 2022/08/14)									
Interharmonic Voltage									
Order h	Avg. %			CP95 %			Max. %		
	Ua	Ub	Uc	Ua	Ub	Uc	Ua	Ub	Uc
TIHD	0.00	0.00	0.00	0.00	0.00	0.00	0.00	0.00	0.00
IH01	0.00	0.00	0.00	0.00	0.00	0.00	0.00	0.00	0.00
IH02	0.00	0.00	0.00	0.00	0.00	0.00	0.00	0.00	0.00
IH03	0.00	0.00	0.00	0.00	0.00	0.00	0.00	0.00	0.00
IH04	0.00	0.00	0.00	0.00	0.00	0.00	0.00	0.00	0.00
IH05	0.00	0.00	0.00	0.00	0.00	0.00	0.00	0.00	0.00
IH06	0.00	0.00	0.00	0.00	0.00	0.00	0.00	0.00	0.00
IH07	0.00	0.00	0.00	0.00	0.00	0.00	0.00	0.00	0.00
IH08	0.00	0.00	0.00	0.00	0.00	0.00	0.00	0.00	0.00
IH09	0.00	0.00	0.00	0.00	0.00	0.00	0.00	0.00	0.00
IH10	0.00	0.00	0.00	0.00	0.00	0.00	0.00	0.00	0.00
IH11	0.00	0.00	0.00	0.00	0.00	0.00	0.00	0.00	0.00
IH12	0.00	0.00	0.00	0.00	0.00	0.00	0.00	0.00	0.00
IH13	0.00	0.00	0.00	0.00	0.00	0.00	0.00	0.00	0.00
IH14	0.00	0.00	0.00	0.00	0.00	0.00	0.00	0.00	0.00

Figure 3-99 Interharmonic Voltage

• Mains Signalling Voltages

EN50160 Report (Week32 2022/08/07 ~ 2022/08/14)							
Mains Signalling Voltages							
Signalling Frequency Hz	Limit %	Compliance %	Measured %			Conclusion	
			Ua	Ub	Uc		
1,000.00	5.00	99.00	100.00	100.00	100.00	✓	
2,000.00	5.00	99.00	100.00	100.00	100.00	✓	
3,000.00	5.00	99.00	100.00	100.00	100.00	✓	

Statistics	Valid Intervals	Invalid Intervals	Valid Intervals Exceed Compliance	Max.	Min.	CP95
MSV1	Ua	201,600	0	0	0.001 V	0.000 V
	Ub	201,600	0	0	0.001 V	0.000 V
	Uc	201,600	0	0	0.001 V	0.000 V
MSV2	Ua	201,600	0	0	0.001 V	0.000 V
	Ub	201,600	0	0	0.001 V	0.000 V
	Uc	201,600	0	0	0.001 V	0.000 V
MSV3	Ua	201,600	0	0	0.001 V	0.000 V
	Ub	201,600	0	0	0.001 V	0.000 V

Figure 3-100 Mains Signalling Voltages

• Interruptions of the Supply Voltage

EN50160 Report (Week32 2022/08/07 ~ 2022/08/14)			
Interruptions of the Supply Voltage			
Duration	t ≤ 1s	1s <t ≤ 3min	3min < t
Count	0	0	0

Figure 3-101 Interruptions of the Supply Voltage

- Supply Voltage Dips

EN50160 Report (Week32 2022/08/07 ~ 2022/08/14)						
Supply Voltage Dips						
Residual Voltage u %	Duration t ms					
	10 ≤ t ≤ 200	200 < t ≤ 500	500 < t ≤ 1000	1000 < t ≤ 5000	5000 < t ≤ 60000	t > 60000
90 > u ≥ 80	0	0	0	0	0	0
80 > u ≥ 70	0	0	0	0	0	0
70 > u ≥ 40	0	0	0	0	0	0
40 > u ≥ 5	0	0	0	0	0	0
5 > u	0	0	0	0	0	0

Figure 3-102 Supply Voltage Dips

- Supply Voltage Swells

EN50160 Report (Week32 2022/08/07 ~ 2022/08/14)				
Supply Voltage Swells				
Swell Voltage u %	Duration t ms			
	10 ≤ t ≤ 500	500 < t ≤ 5000	5000 < t ≤ 60000	t > 60000
u ≥ 200	0	0	0	0
200 > u ≥ 160	0	0	0	0
160 > u ≥ 140	0	0	0	0
140 > u ≥ 120	0	0	0	0
120 > u > 110	0	0	0	0

Figure 3-103 Supply Voltage Swells

- Transient Overvoltages

EN50160 Report (Week32 2022/08/07 ~ 2022/08/14)		
Transient Overvoltages		
Ua Count	Ub Count	Uc Count
0	0	0

Figure 3-104 Transient Overvoltages

Click **Print** to open the preview window. Then click **Print** at the top of the window to confirm the printing of the report, which includes the conclusion page and the details page for each item.

EN50160 Report (Week32 2022/08/07 ~ 2022/08/14)		
		Print
iMeter 7A	EN50160 Report	
Conclusion		
Continuous Phenomena		Period: Week32 2022/08/07 ~ 2022/08/14
No.	Power Quality Parameters	Conclusion
01	Power Frequency	✗
02	Supply Voltage Variations	✗
03	Rapid Voltage Changes	
04	Flicker Severity	✓
05	Supply Voltage Unbalance	✓
06	Harmonic Voltage	✓
07	Interharmonic Voltage	
08	Mains Signalling Voltages	✓
Voltage Events		
No.	Power Quality Parameters	Conclusion
09	Interruptions of the Supply Voltage	
10	Supply Voltage Dips	
11	Supply Voltage Swells	

Figure 3-105 Preview for Printing EN 50160 Report

3.2.3.3.8 IEEE Std 519

Click **IEEE Std 519** at the **Title Bar** to view the IEEE standard 519 weekly report and daily report. Please refer to **Section 4.3.20** for more information. Click **Export** to download the IEEE Std 519-2022 Weekly Report_Weekxx.xls or IEEE Std 519-2022 Daily Report_YYYYMMDD.xls file for the currently selected period.

3.2.3.3.8.1 Weekly Report

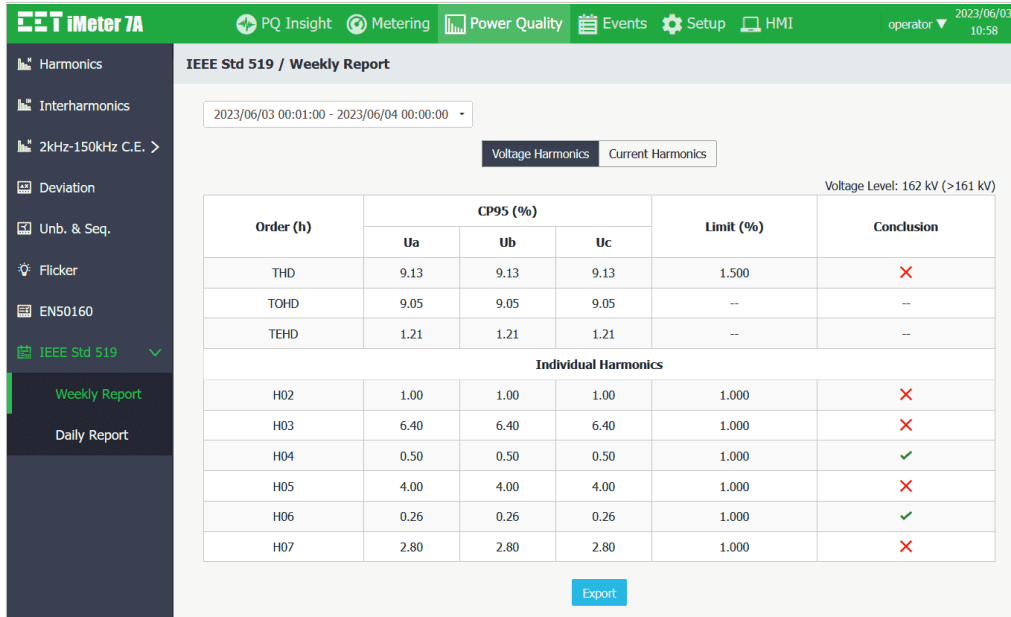

Figure 3-106 IEEE Std 519 Voltage Harmonics Compliance Weekly Report

3.2.3.3.8.2 Daily Report

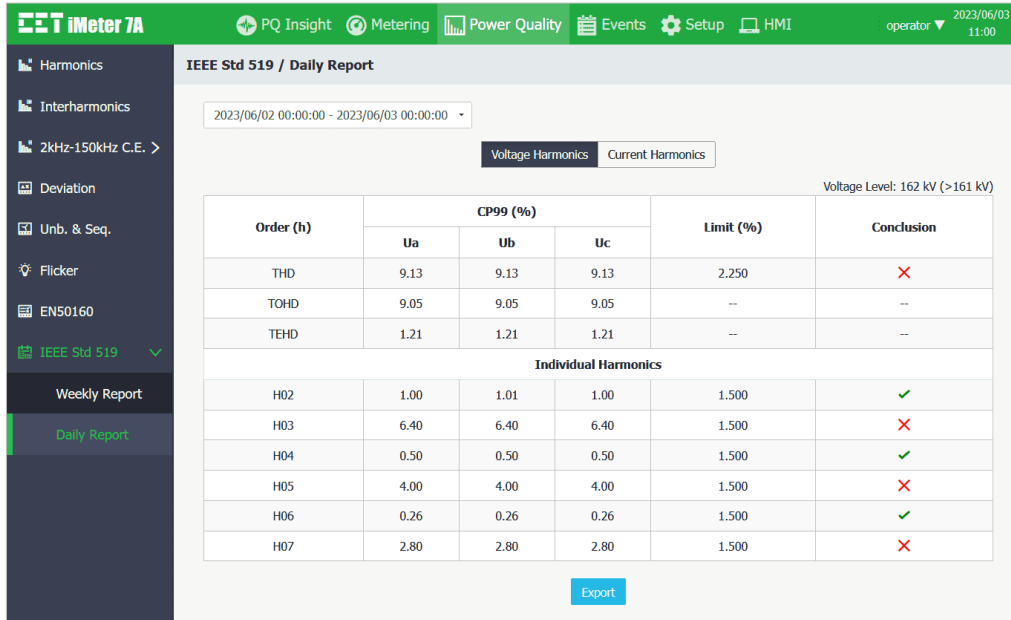

Figure 3-107 IEEE Std 519 Voltage Harmonics Compliance Daily Report

3.2.3.4 Events

Click **Events** at the **Title Bar** and its sub-menus appear on the left-hand pane which includes **SOE Log**, **Device Log** and **PQ Counters**. The following sections provide a quick overview of these web pages.

3.2.3.4.1 SOE Log

Click **SOE Log** on the left-hand pane to display the SOE Log on the right-hand pane starting with the most recent events. The interface supports the following filtering mechanisms.

- Search Period:** Use the drop-down box on the left to select a specific period.
- Event Type:** Use the drop-down box in the middle to select a particular event type such as Dip/Swell, Transient, RVC, MSV, Inrush Current, Setpoint, I/O, Record (WFR, DWR, RMSR and DR) and Motor Start.
- Keyword Search:** Enter a keyword in the text box on the right to search for events that contain the keyword.

Click on a specific event to display the event details.

Click **Export** to save all SOE events to a .csv file at the default Download folder.

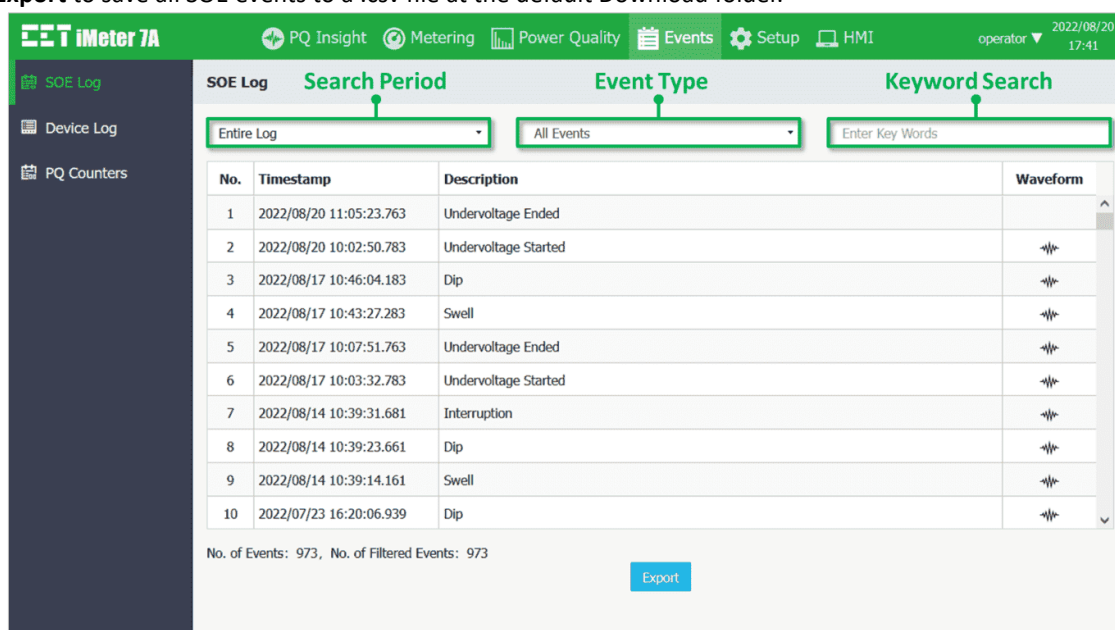

Figure 3-108 SOE Log Interface

Here are several examples of SOE Log details:

- 1) DO1 Closed:

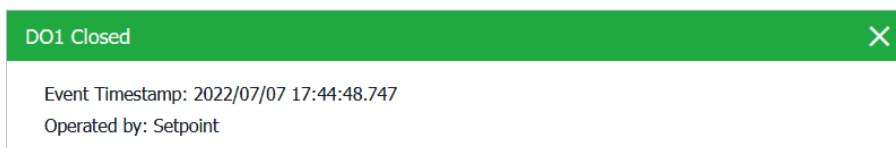

Figure 3-109 DO1 Operated by a Setpoint Event

- 2) Over Uln Setpoint Return:

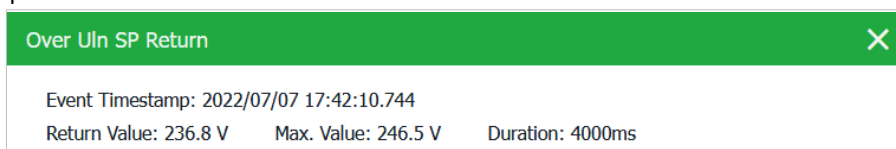



Figure 3-110 Over Uln Setpoint Return

3) Over Uln Setpoint Active:



Figure 3-111 Over Uln Setpoint Active

Inside the waveform display, there are four control icons .

 These two icons are used to zoom in and out of the waveforms based on the time scale.

 This icon is used to reset the waveform display back to its default resolution.

 This icon is used to export the waveform file in COMTRADE format to a compressed folder.

There is also a scroll bar at the bottom that allows the waveform to be scrolled forward and backward.

- 4) When a PQ Setpoint is configured to trigger WFR (**Waveform Recorder**), DWR (**Disturbance Waveform Recorder**), and/or RMSR (**RMS Recording**), the recorded Swell events will have the option of showing the ITIC plot while the Dip/Interruptions events will have the option of showing both the ITIC and SEMI F47 plots, along with the WFR/DWR/RMSR waveform.



Figure 3-112 Interruption on SEMI F47 Interface

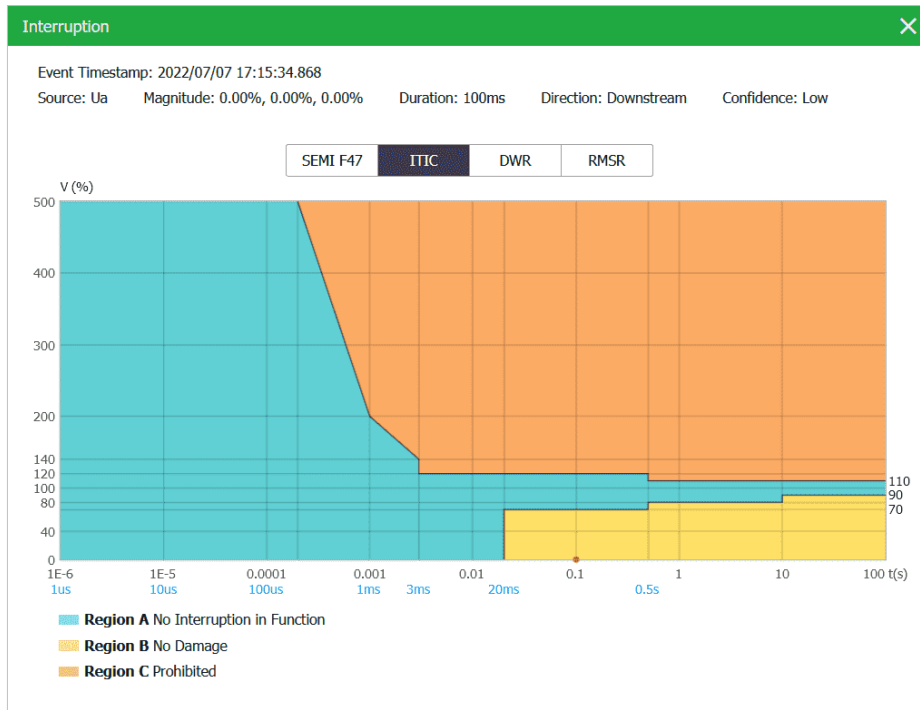

Figure 3-113 Interruption on ITIC Interface



Figure 3-114 RMSR for Interruption Event

3.2.3.4.2 Device Log

Click **Device Log** on the left-hand pane to display the Device Log on the right-hand pane starting with the most recent events.

Also, the interface supports the following filtering mechanism.

Search Period: Use the drop-down box on the left to select a specific period.

Keyword Search: Enter a keyword in the text box on the right to search for events that contain the keyword.

Click **Export** to save the data to a .csv file at the default Download folder.

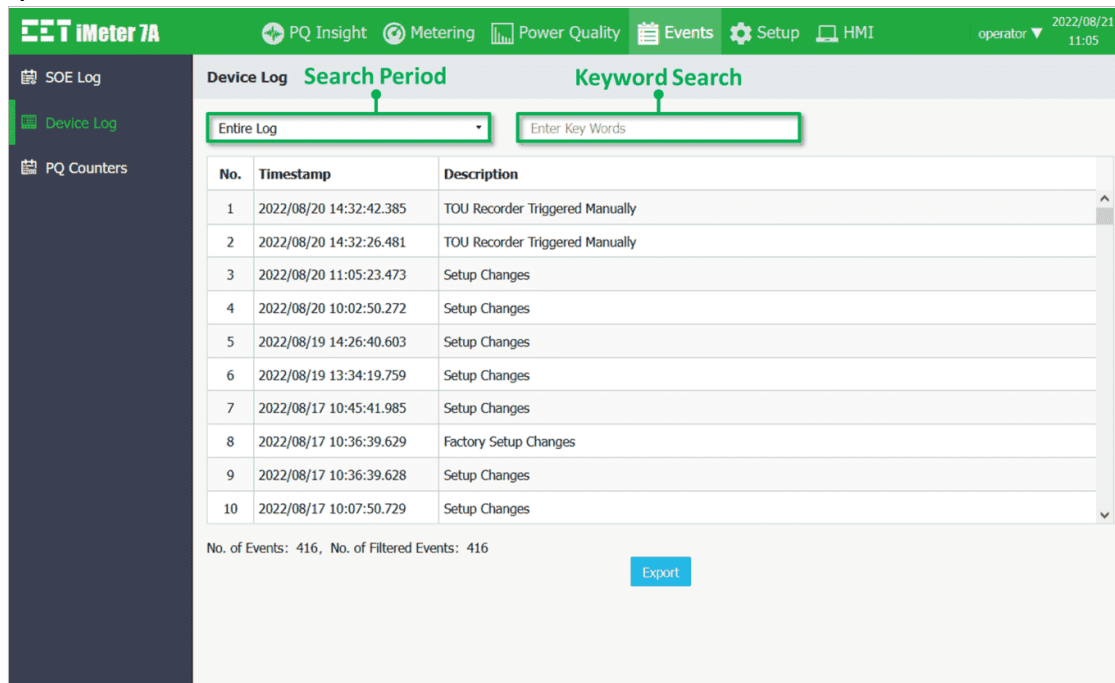

Figure 3-115 Device Log Interface

3.2.3.4.3 PQ Counters

Click **PQ Counters** on the left-hand pane to display different PQ Counters such as **Dips, Swells, Interruptions, Transients, RVC, Inrush Current** and **MSV** on the right-hand pane.

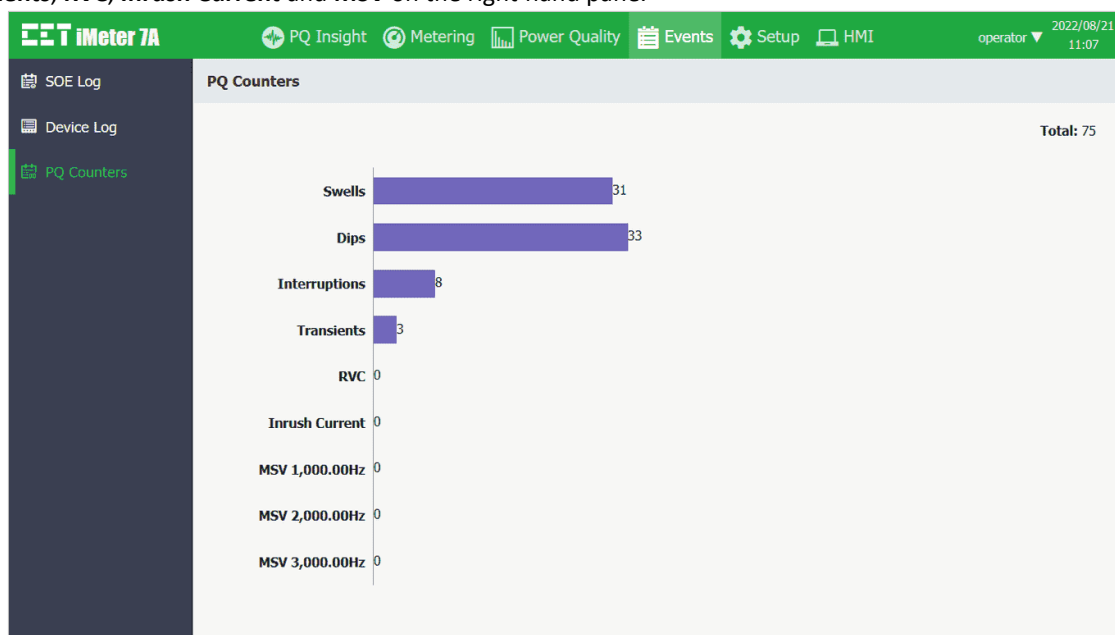

Figure 3-116 PQ Counters Interface

3.2.3.5 Setup

Click **Setup** at the **Title Bar** and its sub-menus appear on the left-hand pane which includes **Basic, Comm., Dmd. & Energy, Dmd. & Energy, PQ, Record, Setpoint, I/O, Clock, Email** and **Diagnostics**.

3.2.3.5.1 Basic

Click **Basic** on the left-hand pane and the following screen appears which has three tabs: **Basic, UI, and Fault Monitoring**.

3.2.3.5.1.1 Basic > Basic Settings

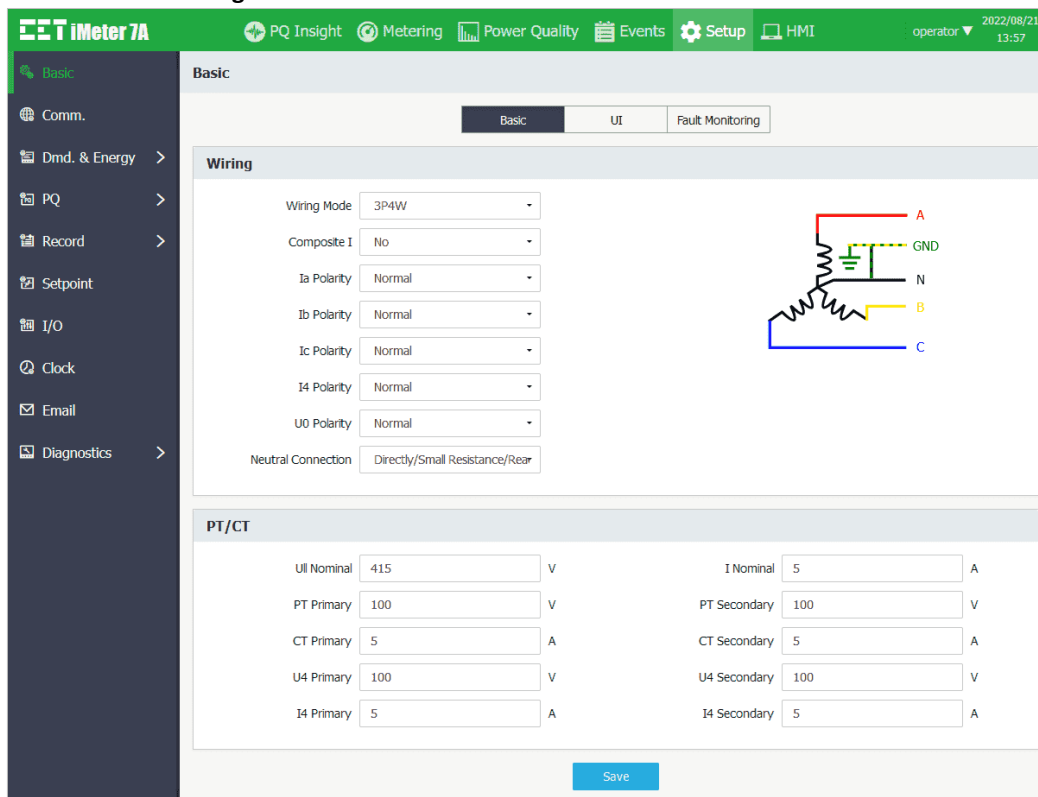

Figure 3-117 Basic Settings Interface

The following table illustrates the ranges and default values for the basic parameters.

Parameter	Range/Default*	Parameter	Range/Default*
Wiring		PT/CT	
Wiring Mode	3P4W*, 3P3W, DEMO	Ull Nominal	1 to 1500V, 415V*
Composite I	No*/Ia/Ib/Ic	I Nominal	1 to 1000A, 5A*
Ia/Ib/Ic/I4/U0 Polarity	Ia Normal*/Reverse, Ib Normal*/Reverse, Ic Normal*/Reverse, I4 Normal*/Reverse	PT Primary	1 to 1000000V, 100V*
		PT Secondary	1 to 1500V, 100V*
		CT Primary	1 to 30000A, 5A*
		CT Secondary	1 to 50A, 5A*
Neutral Connection	Direct/Small Resistance/Reactance Grounded*, Ungrounded/High Resistance, Arc Suppression Coil	U4 Primary	1 to 1000000V, 100V*
		U4 Secondary	1 to 1500V, 100V*
		I4 Primary	1 to 30000A, 5A*
		I4 Secondary	1 to 50A, 5A*

Table 3-5 Basic Parameters

Click on the wiring graphics on the right-hand side to set the **Channels Color**:



Figure 3-118 Channels Color Settings

3.2.3.5.1.2 Basic > UI

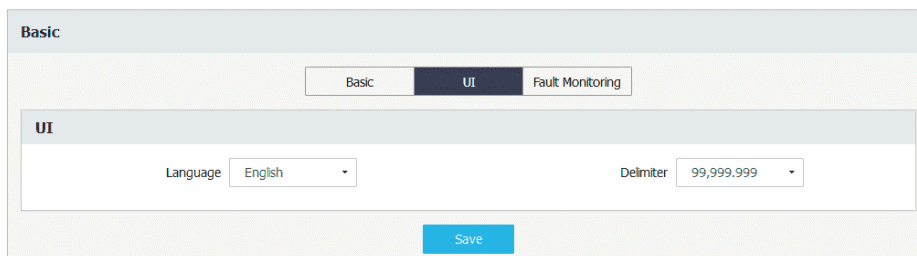

Figure 3-119 UI Settings Interface

3.2.3.5.1.3 Basic > Fault Monitoring

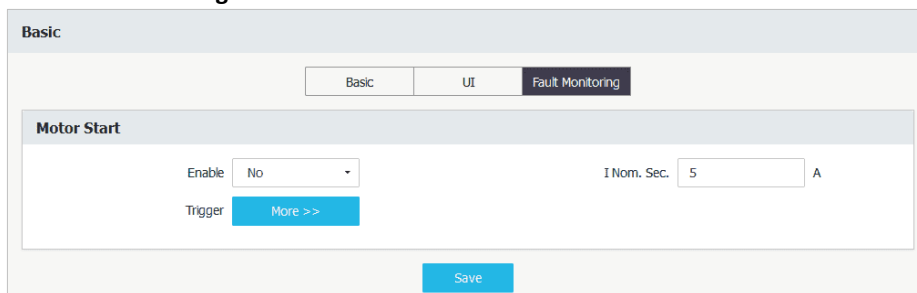

Figure 3-120 Motor Start Monitoring Settings Interface

The following table illustrates the ranges and default values for Motor Start Monitoring settings.

Parameter	Range/Default*	Parameter	Range/Default*
Enable	Yes/No*	I Nominal Secondary	1-600 (x0.01A), 500*
Trigger	DWR, WFR*, RMSR*, iTrigger 1, iTrigger 2, iTrigger 3, Alarm, DO1 to DO5		

Figure 3-121 Motor Start Monitoring Setup

3.2.3.5.2 Comm.

3.2.3.5.2.1 Comm. > Basic

Click **Comm.** on the left-hand pane and the following screen appears which has three tabs: **Basic**, **Advanced**, **VPN**, **Cloud** and **Dial**.

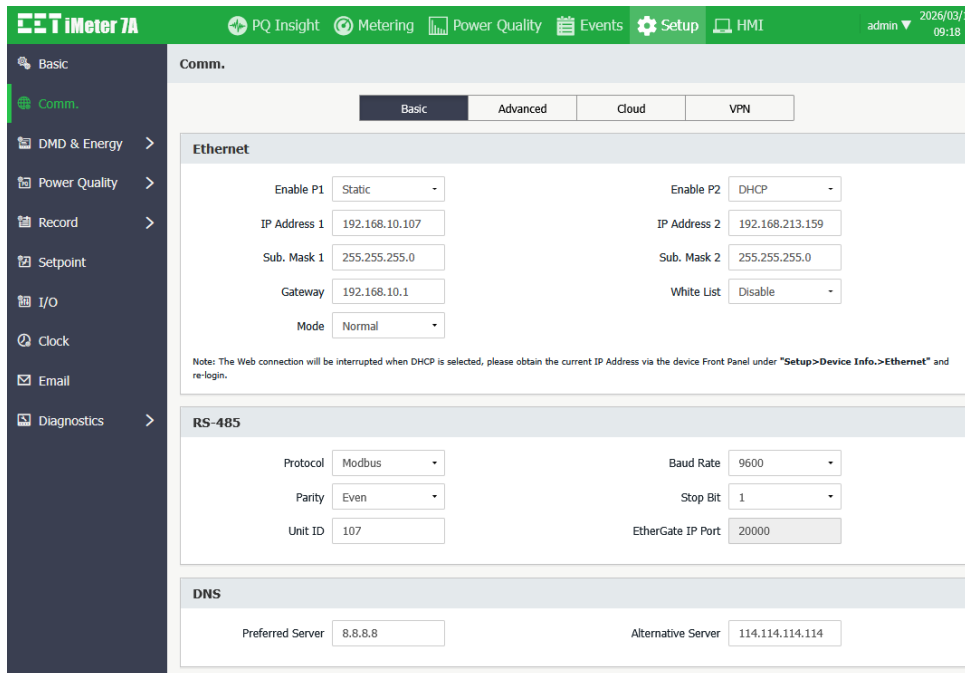

Figure 3-122 Basic Communications Setup Interface

The following table illustrates the setup range and default values for Basic Communications parameters.

Parameter	Range/Default*	Parameter	Range/Default*
Ethernet		RS-485	
Enable P1/P2 ¹	No, Static*, DHCP	Protocol	Modbus*, EtherGate, Disable
IP Address P1 ²	192.168.0.100*	Baud Rate	1200, 2400, 4800, 9600*, 19200, 38400
IP Address P2	192.168.1.100*	Parity	None, Odd, Even*
Subnet Mask 1/2	255.255.255.0*	Stop Bit	1, 2*
Gateway	192.168.0.1*	Unit ID	1 to 247, 100*
White List	Disabled*, Enabled	EtherGate IP Port	20000 to 60000, 20000*
Mode [~]	Switch, Normal, RSTP		
RSTP List[~] (Available when the Mode is set to RSTP)			
Please note the RSTP parameters must satisfy: 2 x (Forward Delay – 1 s) ≥ Max Age ≥ 2 x (Hello Time + 1 s)			
Priority	0 to 15 s, 8*	Hello Time	1 to 10 s, 2*
Max Age	6 to 40 s, 20	Forward Delay	4 to 40 s, 15*
Port1 Pathcost	0 to 200000, 0 (Auto)	Port1 Priority	0 to 15, 8*
Port2 Pathcost	0 to 200000, 0 (Auto)	Port2 Priority	0 to 15, 8*
DNS			
Preferred Server	8.8.8.8*	Alternative Server	114.114.114.114*

[~] Available in Firmware V2.50.08 or later

Table 3-6 Basic Communications Setup Parameters

Notes:

1. The Web connection will be interrupted when **DHCP** is selected, please obtain the current IP address via the device Front Panel under **Setup > Device Info. > Ethernet** and re-login.
2. Please note that the IP Addresses for P1 and P2 should not be in the same segment.

3.2.3.5.2.2 Comm. > Advanced

The screenshot shows the 'Comm.' configuration page with the 'Advanced' tab selected. It contains five sections: Modbus TCP, Web, IEC 61850*, FTPS, and SNMP. Each section has 'Enable' and 'Port' fields, and some have additional fields like 'ID', 'SSL/TLS Enable', 'Read-only Password', and 'Read-write Password'. A 'Save' button is at the bottom.

Figure 3-123 Advanced Communications Setup Interface

The following table illustrates the setup range and default values for Advanced Communications parameters.

Parameter	Range/Default*	Parameter	Range/Default*
Modbus TCP		Web	
Enable	Yes*, No	Enable	Yes*, No
ID	1-247, 100	HTTPS Port	1-65535, 443
Port	1-65535, 502	SSL/TLS Enable	Yes, No*
IEC 61850 ¹		HTTP Port	1-65535, 80
Enable		FTPS	
Port	1-65535	Enable	Yes*, No
IED Name		SSL/TLS Enable	Yes, No*
SNMP		Port	1-65535, 21
Enable	Yes, No*		
Port	1-65535, 161		
Read-only Password	public		
Read-write Password	private		

Table 3-7 Advanced Communications Setup Parameters

Notes:

1. Please reboot the device under **Setup** -> **Diagnostics** -> **Maintenance** -> **Restart** for the changes to take effect.

3.2.3.5.2.3 Comm. > VPN

Comm.

Basic Advanced **VPN** Cloud

Basic

Operating Mode: Peer Address: [PING](#)

Start Mode: Exchange Mode:

Local Subnet Address: Peer Subnet Address:

Local Subnet Mask: Peer Subnet Mask:

Local Subnet Address Peer Subnet Address

IKE Parameters

Protocol Version: Proposal:

Local Identity Mode: Local Identity:

Peer Identity Mode: Peer Identity:

Authentication Mode: Key:

Lifetime: s

IPSec Parameters

Protocol: Proposal:

Lifetime: s

Keep-Alive Parameters

PING Interval: s PING Target Address:

Reconnection Interval: s

Note: Numeric "0" for Interval represents that Ping or Reconnection is disabled.

[Save](#)

Figure 3-124 VPN Setup Interface

3.2.3.5.2.4 Comm. > Cloud

Comm.

Basic Advanced VPN **Cloud**

Basic Settings

Enable: Encryption:

File Upload Port: Data Upload Port:

Server Address:

Upload Settings

Upload Interval: s Real Time: [More >>](#)

Harmonics: [More >>](#) Interharmonics: [More >>](#)

Log: [More >>](#) 2k-150kHz C.E.: [More >>](#)

[Save](#)

Figure 3-125 Cloud Setup Interface

3.2.3.5.3 Dmd. & Energy

Click **Dmd. & Energy** on the left-hand pane to expand its sub-menu to show **Demand, Energy, TOU** and **Algorithm**.

3.2.3.5.3.1 Demand

For more information, please refer to **Section 4.2.4**.

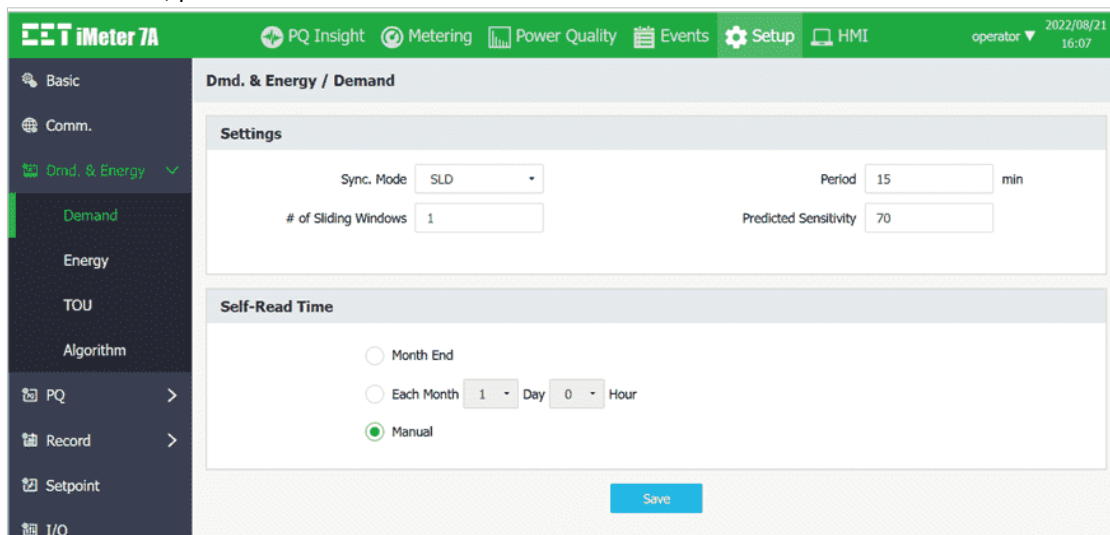

Figure 3-126 Demand Setup Interface

The following table illustrates the setup range and default values for Demand Setup parameters.

Parameter	Range/Default*	Parameter	Range/Default*
Settings			
Sync. Mode	SLD*, Sync. DI	Period	1 to 60 min, 15*
# of Sliding Windows	1 to 15, 15*	Predicted Sensitivity	70 to 99, 70*
Self-Read Time			
Self-Read Time	Month End, Each Month X (X = 1 to 28) Day Y (Y = 0 to 23) Hour, Manual*		

Table 3-8 Demand Setup Parameters

3.2.3.5.3.2 Energy

Click **Energy** on the left-hand pane to access the **Energy Preset**, **Energy Pulse** and **Energy Log** configurations.

- **Energy Preset** Supports the presetting of kWh Import/Export, kvarh Import/Export and kVAh Total. The valid range for the pre-defined energy should be between 0 to 99,999,999,999.

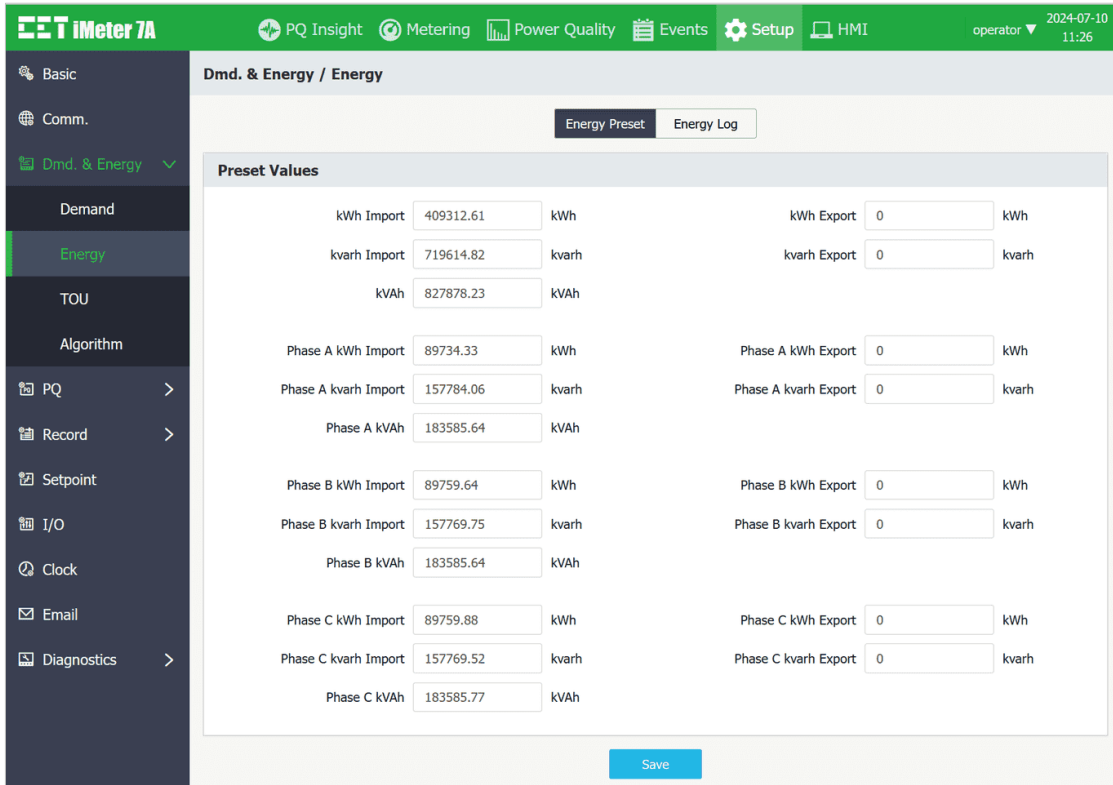

Figure 3-127 Energy Preset Interface

- **Energy Log** Please refer to **Section 4.6.1** for a detailed description of the parameters below.

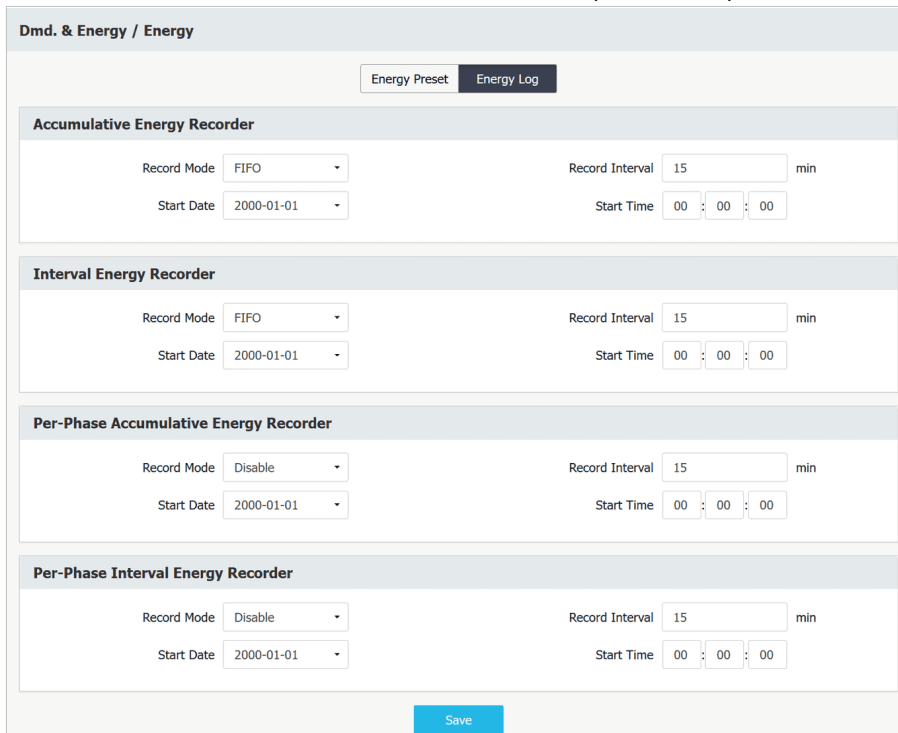

Figure 3-128 Energy Log Setup Interface

- Energy Pulse (Optional)

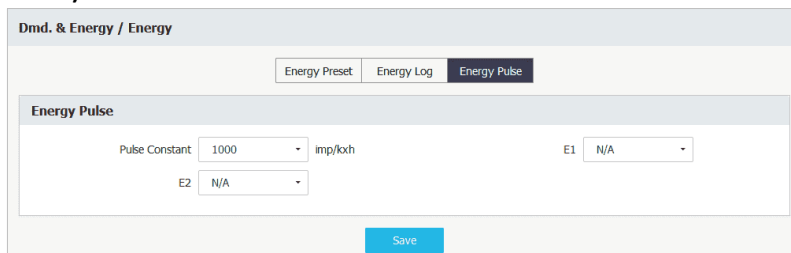

Figure 3-129 Energy Pulse Setup Interface

3.2.3.5.3.3 TOU

Click on **TOU** to access the **Labels, Basic, Daily Profiles, Seasons** and **Alternate Days** configurations.

- Labels

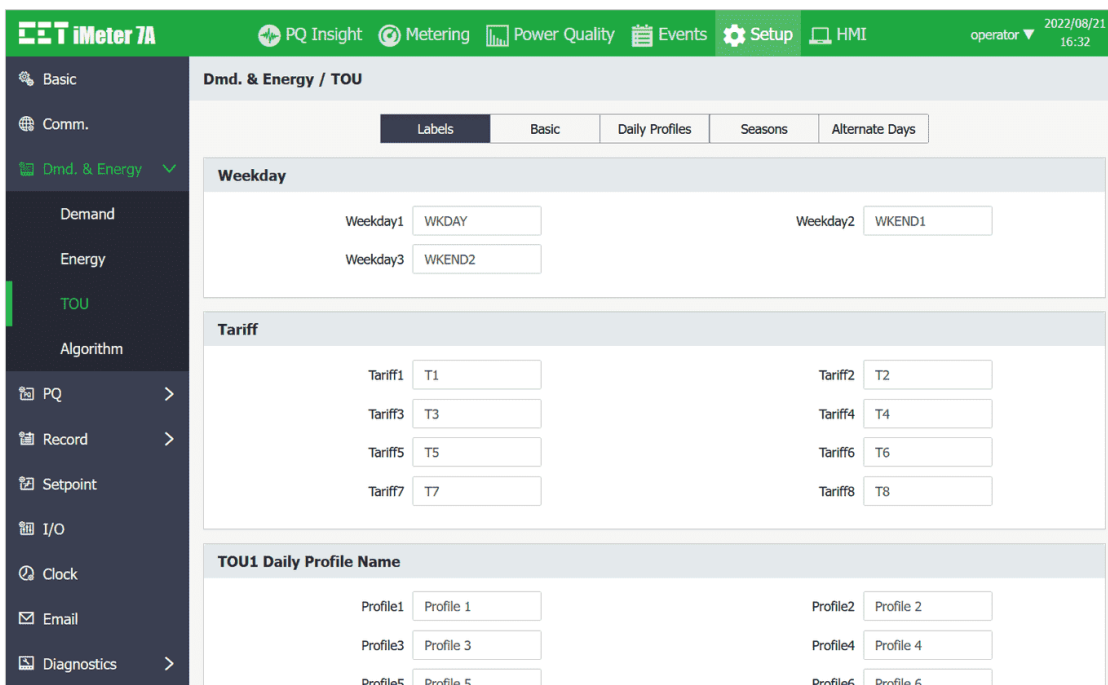

Figure 3-130 Labels Setup Interface

- Basic

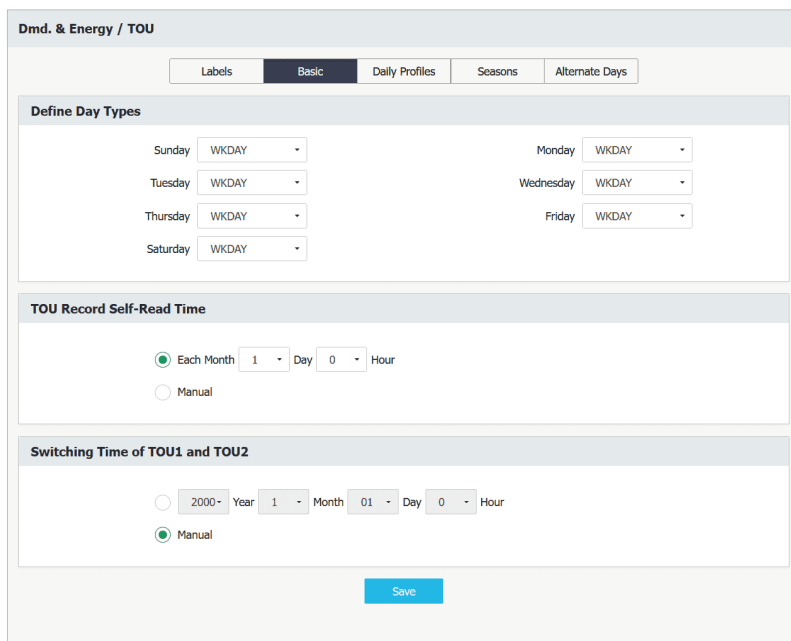

Figure 3-131 Basic Settings Interface

• Daily Profiles

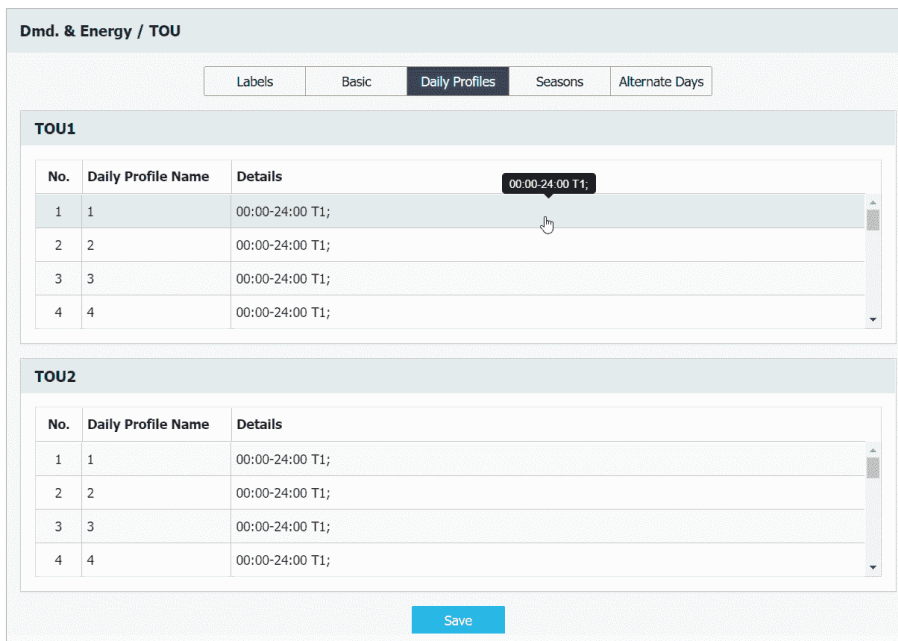

Figure 3-132 Daily Profiles Setup Interface

Click on a particular **Daily Profile** and the following dialog box appears which allows the **Start Time** and **Tariff** for each **Period** to be defined until the entire day has been filled. As **Figure 3-133** shown, the **Start Time** for the first **Period** is fixed at 00:00 and cannot be modified. Each **Daily Profile** supports a maximum of 20 **Periods** in a 15-minute resolution. The **Start Time** of the next **Period** defines the end time of the previous **Period**. Click **+** to add a new **Period** or **🗑** to clear the current **Period's** settings. The last defined **Period** will end at 24:00.

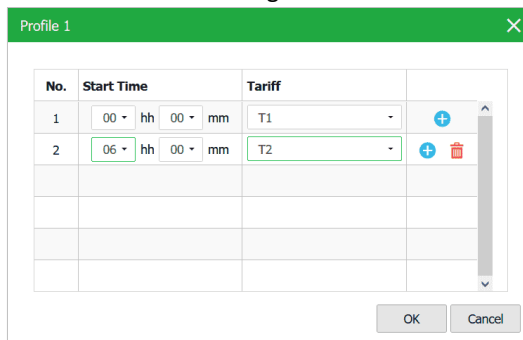

Figure 3-133 TOU – DP1 Setting Dialog

• **Seasons**



Click on **Seasons** and the following page appears which allows the **Start Date**, **WKDAY Daily Profile**, **WKEND1 Daily Profile**, and **WKEND2 Daily Profile** each **Season** to be defined until the entire year has been filled. Up to 12 seasons can be defined for each TOU. The **Start Date** for the first **Season** is programmable and defaults to 01/01 since firmware V2.50.03 (In firmware prior to V2.50.03, the **Start Date** for the first **Season** is fixed to 01/01 and cannot be changed). The **Start Date** of the next **Season** defines the end date of the previous **Season**. Click **+** to add a new **Season** or **🗑** to clear the current **Season's** settings. The last defined **Season** will end on 12/31.

Figure 3-134 Seasons Setup Interface

• **Alternate Days**

Click on **Alternate Days** and the following screen appears which allows up to 90 Alternate Days to be defined for each TOU. Click the **<Add>** button to start the configuration.

Figure 3-135 TOU – Alternate Days

Click  to add a new Alternate Day or  to clear the setting for the current Alternate Day.

Dmd. & Energy / TOU

Labels Basic Daily Profiles Seasons **Alternate Days**

TOU1

No.	Date	Daily Profile
1	Each Y Each M 01 D	Profile 1

TOU2

Click **Add** to set Alternate Days

Add

Save

Figure 3-136 Alternate Days Setup Interface

3.2.3.5.3.4 Algorithm

iMeter 7A PQ Insight Metering Power Quality Events Setup HMI operator 2022/08/21 16:44

Dmd. & Energy / Algorithm

Power Algorithm

PF Convention IEC KVA Calculation Vector

Save

Figure 3-137 Power Algorithm Setup Interface

3.2.3.5.4 PQ

Click **PQ** on the left-hand pane to expand the sub-menu to show **Settings, EN 50160** and **IEEE Std 519**.

3.2.3.5.4.1 PQ > Settings

This web page has seven tabs: **PQ Disturbance, Transient, RVC, MSV, Inrush Current, Harmonics** and **Flicker**.

- **PQ Disturbance** For more information, please refer to **Section 4.3.5**.

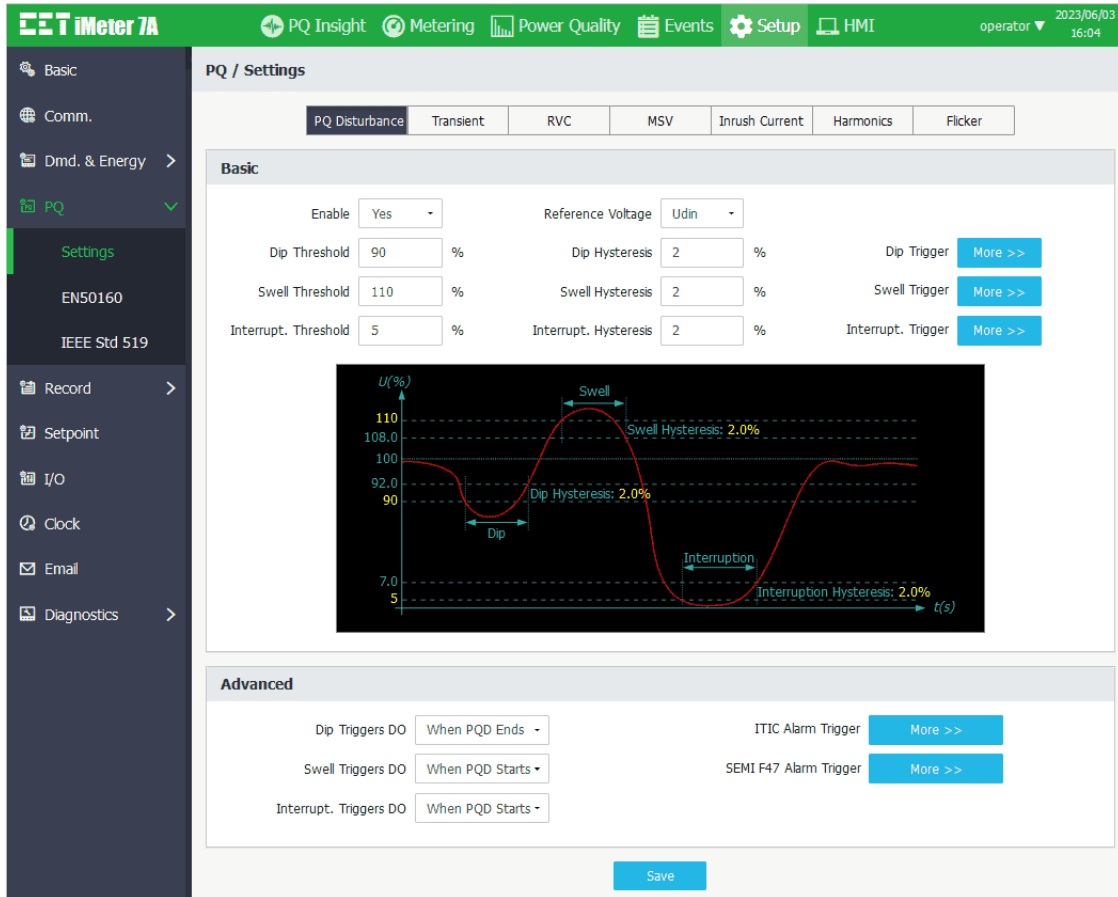

Figure 3-138 PQ Disturbance Settings Interface

- **Transient** For more information, please refer to **Section 4.3.6**.

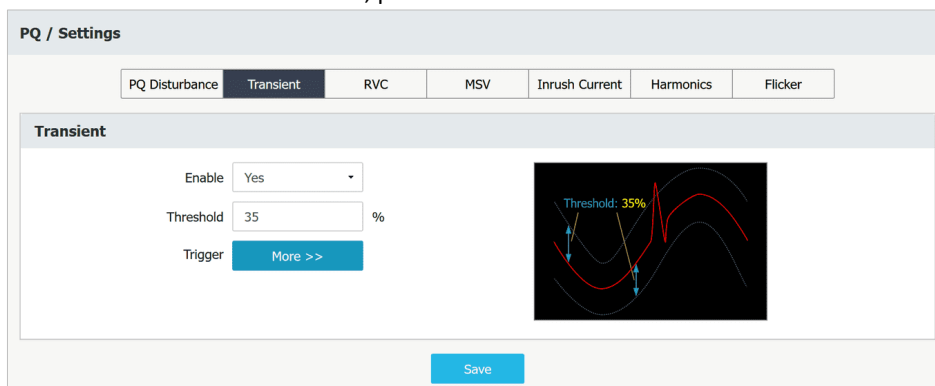

Figure 3-139 Transient Settings Interface

- RVC

For more information, please refer to Section 4.3.13.

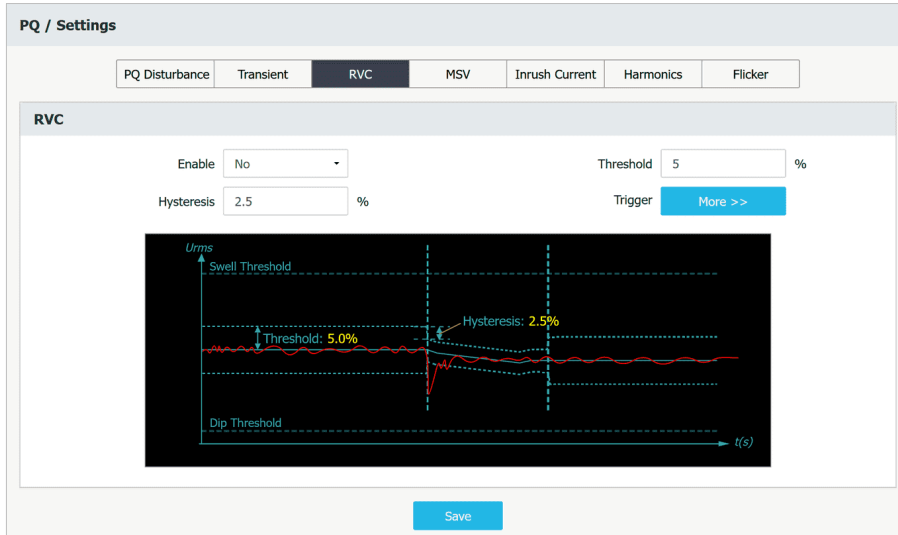

Figure 3-140 RVC Settings Interface

- MSV

For more information, please refer to Section 4.3.12.

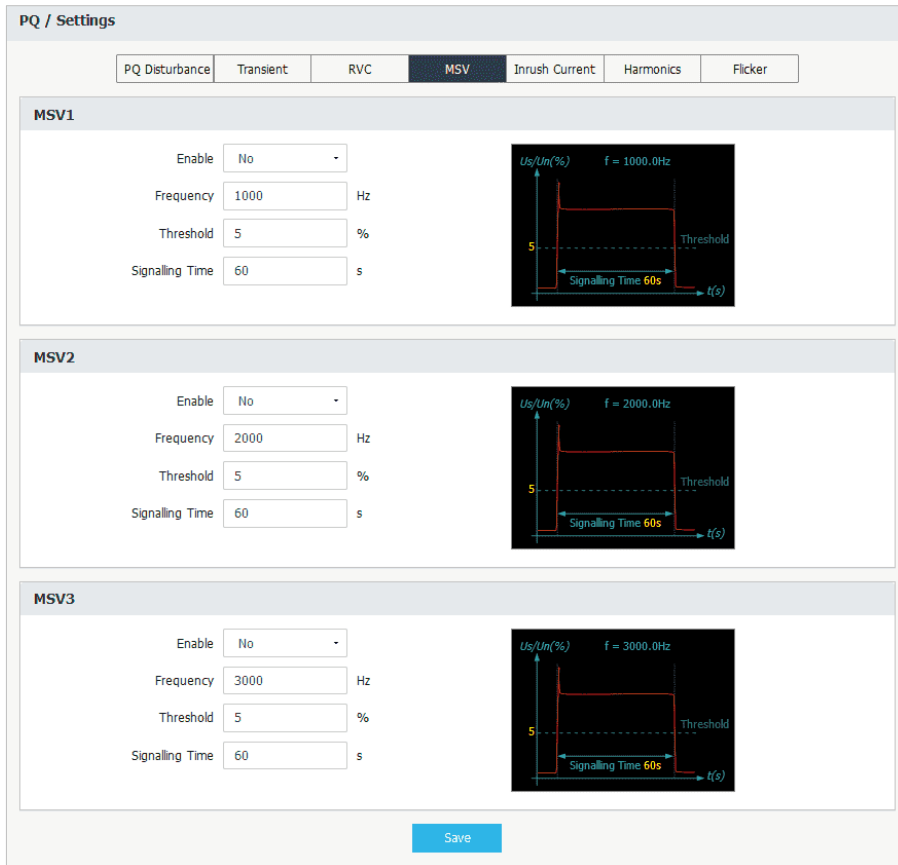

Figure 3-141 MSV Settings Interface

- Inrush Current** For more information, please refer to **Section 4.3.17**.

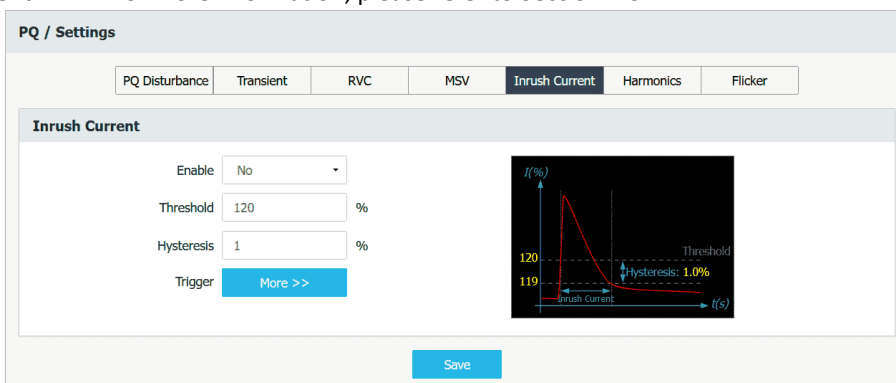

Figure 3-142 Inrush Current Settings Interface

- Harmonics** For more information, please refer to **Section 4.3.9**.

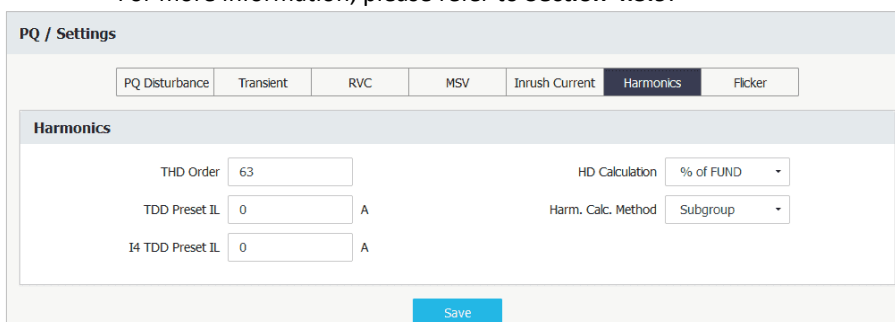

Figure 3-143 Harmonics Settings Interface

The following table illustrates the setup range and default values for Harmonics Setup parameters.

Parameter	Range/Default*	Parameter	Range/Default*
Harmonics			
THD Order	2 to 63, 63*	HD Calculation	% of FUND*, % of RMS, % of UN
TDD Preset IL#	0 to 30000 (x0.001A), 0*	Harm. Cal. Method	Subgroup*, Group
I4 TDD Preset IL#			

Table 3-9 Harmonics Setup Parameters

#TDD Preset IL ≠ 0: The predefined IL value is used for the TDD calculation.

TDD Preset IL = 0: Measured IL is used for the TDD calculation according to the IEEE 519-2022 standard

- Flicker** The options for **Flicker Curve** are 120V and 230V (default). For more information, please refer to **Section 4.3.4**.

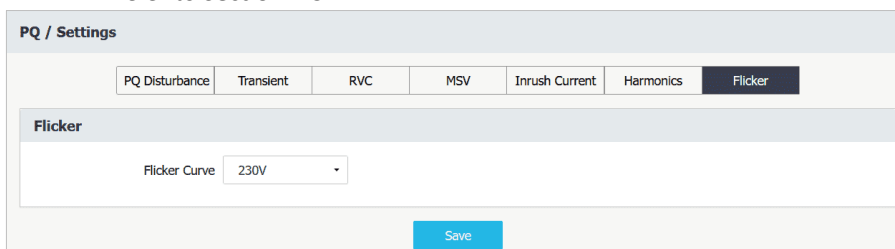

Figure 3-144 Flicker Settings Interface

3.2.3.5.4.2 PQ > EN50160

This page allows the users to setup the **Voltage Level** and **First Day of Week** for the EN 50160 reporting.

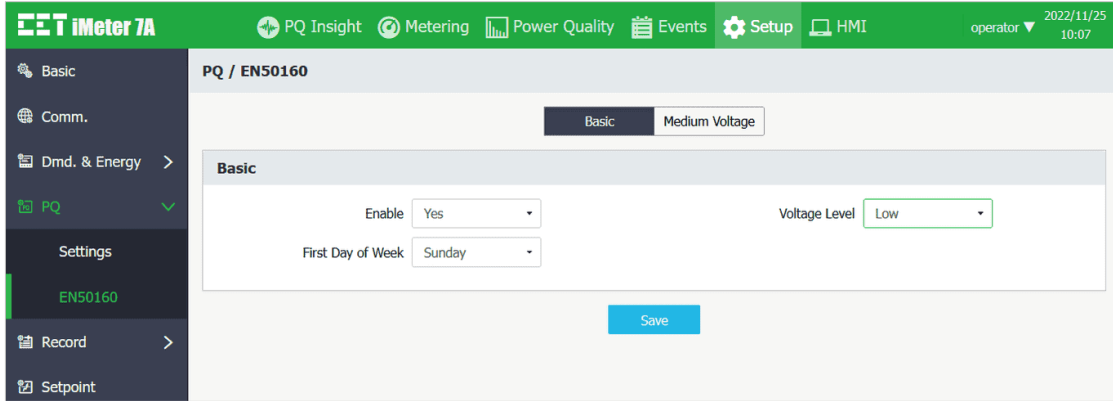

Figure 3-145 EN 50160 Basic Setup Interface

Figure 3-146 below illustrates the default limits of the EN 50160 parameters according to the **Voltage Level** setting, which is Low in this instance. For more information, please refer to **Section 4.3.18**.

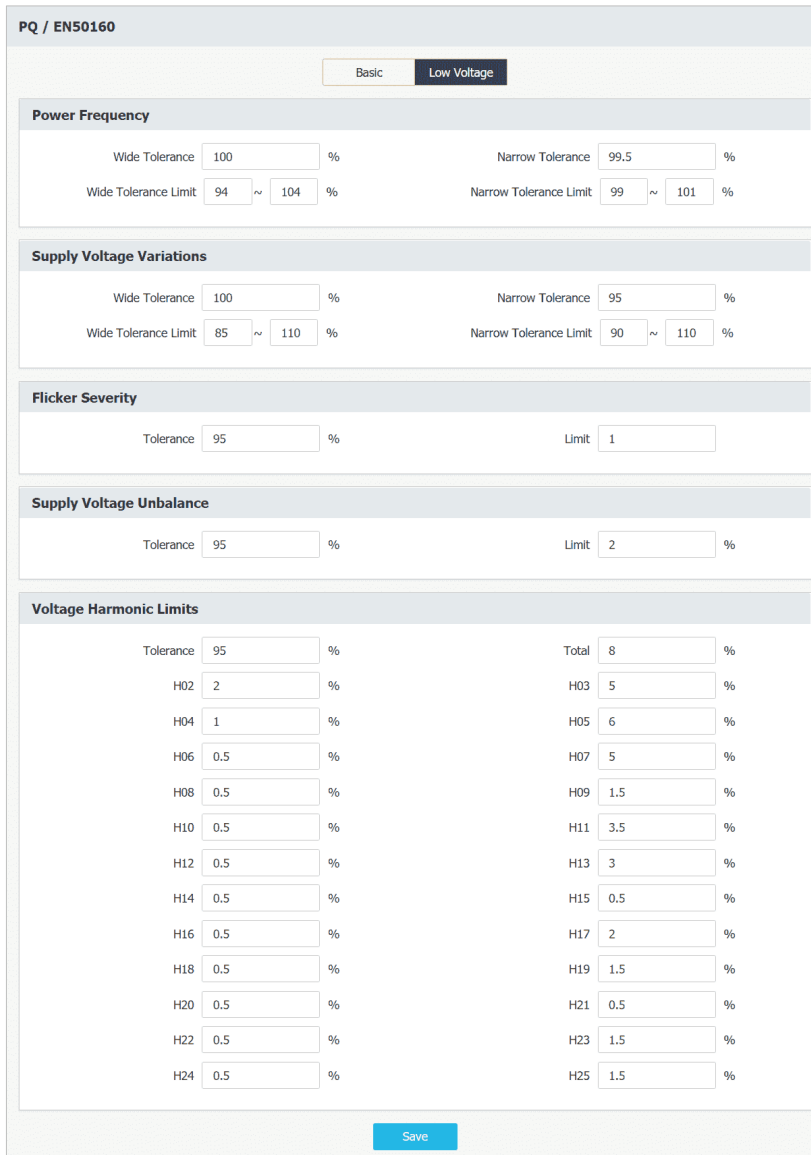

Figure 3-146 Default Limits of the EN 50160 Parameters for Low Voltage

3.2.3.5.4.3 PQ > IEEE Std 519

This page allows the users to configure the IEEE Std 519 report related parameters. For more information, please refer to Table 4-23.

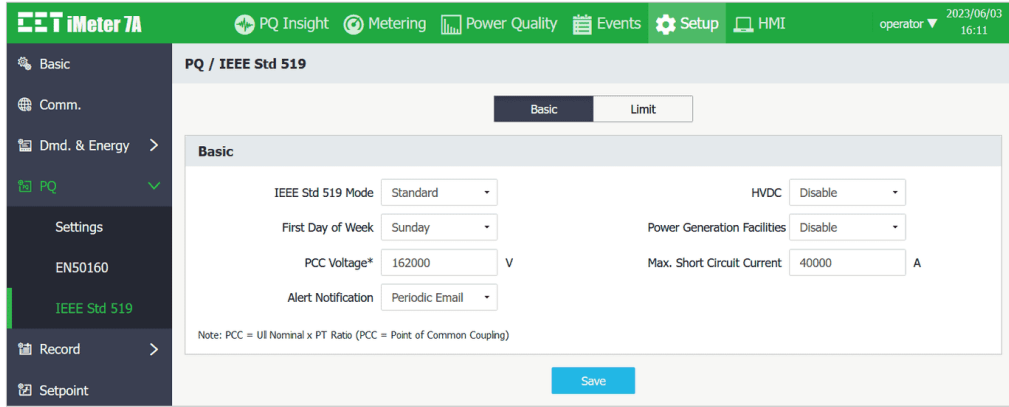

Figure 3-147 IEEE Std 519 Basic Configuration

Figure 3-148 illustrates the default voltage harmonic limits of the IEEE Std 519-2022 according to the PCC Voltage setting, which is at > 161kV level in this instance. For more information, please refer to Section 4.3.20.



Figure 3-148 Default Voltage Harmonic Limits of IEEE Std 519-2022 for Above 161kV Systems

Figure 3-149 illustrates the default current harmonic limits of the IEEE Std 519-2022 according to the SCR Ratio (<25), and PCC Voltage setting, which is at > 161kV in this instance. For more information, please refer to **Section 4.3.20**.

Current Harmonics		
TDD	1.5	%
H03	1	%
H05	1	%
H07	1	%
H09	1	%
H11	0.5	%
H13	0.5	%
H15	0.5	%
H17	0.38	%
H19	0.38	%
H21	0.38	%
H23	0.15	%
H25	0.15	%
H27	0.15	%
H29	0.15	%
H31	0.15	%
H33	0.15	%
H35	0.1	%
H37	0.1	%
H39	0.1	%
H41	0.1	%
H43	0.1	%
H45	0.1	%
H47	0.1	%
H49	0.1	%
H02	0.5	%
H04	0.5	%
H06	0.5	%
H08	1	%
H10	1	%
H12	0.5	%
H14	0.5	%
H16	0.5	%
H18	0.38	%
H20	0.38	%
H22	0.38	%
H24	0.15	%
H26	0.15	%
H28	0.15	%
H30	0.15	%
H32	0.15	%
H34	0.15	%
H36	0.1	%
H38	0.1	%
H40	0.1	%
H42	0.1	%
H44	0.1	%
H46	0.1	%
H48	0.1	%
H50	0.1	%

Figure 3-149 Default Current Harmonic Limits for SCR Ratio < 25, Above 161kV Power Systems

3.2.3.5.5 Record

Click **Record** on the left-hand pane to expand its sub-menu which includes **Waveform**, **SDR**, **Max./Min.** and **DR**.

3.2.3.5.5.1 Waveform

Click **Waveform** on the left-hand pane and the following page appears which has five tabs: **WFR**, **DWR**, **RMSR**, **Sche.** **WFR** and **iTrigger**.

- **WFR** For more information, please refer to **Section 4.6.1**

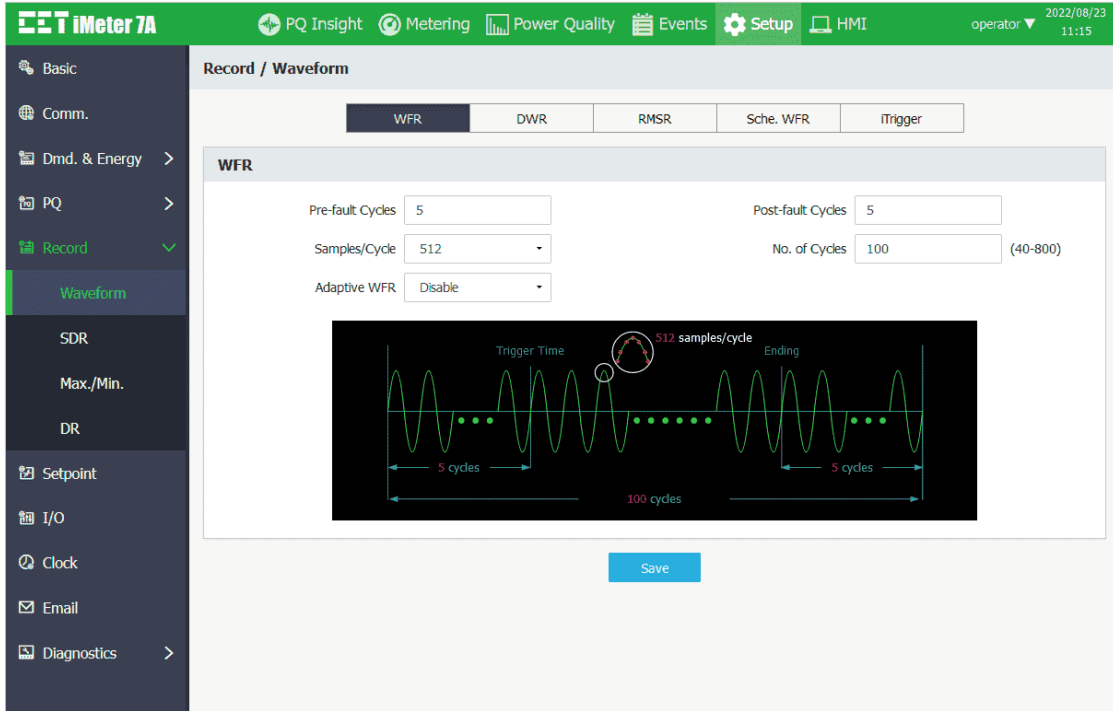

Figure 3-150 WFR Settings Interface

- **DWR** Click **DWR** near the top of the page and the following page appears which provides the **Pre-fault Cycles** settings. The range of **Pre-fault Cycles** is 5 to 10, with 5 being the default. For more information, please refer to **Section 4.6.3**



Figure 3-151 DWR Settings Interface



- RMSR** Click “+ Add” to add a batch of parameters by selecting one or more desired parameters from the **RMSR Source Parameters Dialog Box** (See Figure 3-153) or “De-select All” to remove all existing parameters. Click  on the right-hand column to edit an existing parameter or  to remove a particular parameter. For more information, please refer to **Section 4.6.4**.

Figure 3-152 RMSR Setup Interface

Figure 3-153 RMSR Source Parameters Dialog Box

- Sche. WFR (Scheduled WFR)**
 For more information, please refer to **Section 4.6.2**

Figure 3-154 Sche. WFR Settings Interface

- **iTrigger** For more information, please refer to **Section 4.7**.

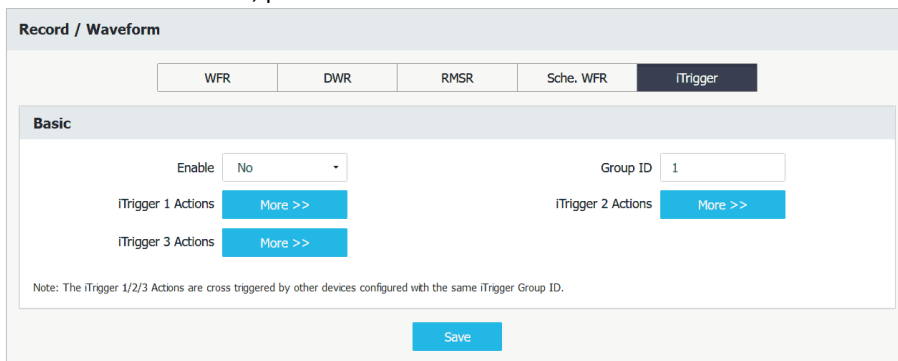

Figure 3-155 iTrigger Setup Interface

3.2.3.5.5.2 SDR

The iMeter 7A comes standard with 8 Statistical Data Recorders of 64 parameters each. Please refer to **Section 4.6.7** for more information.

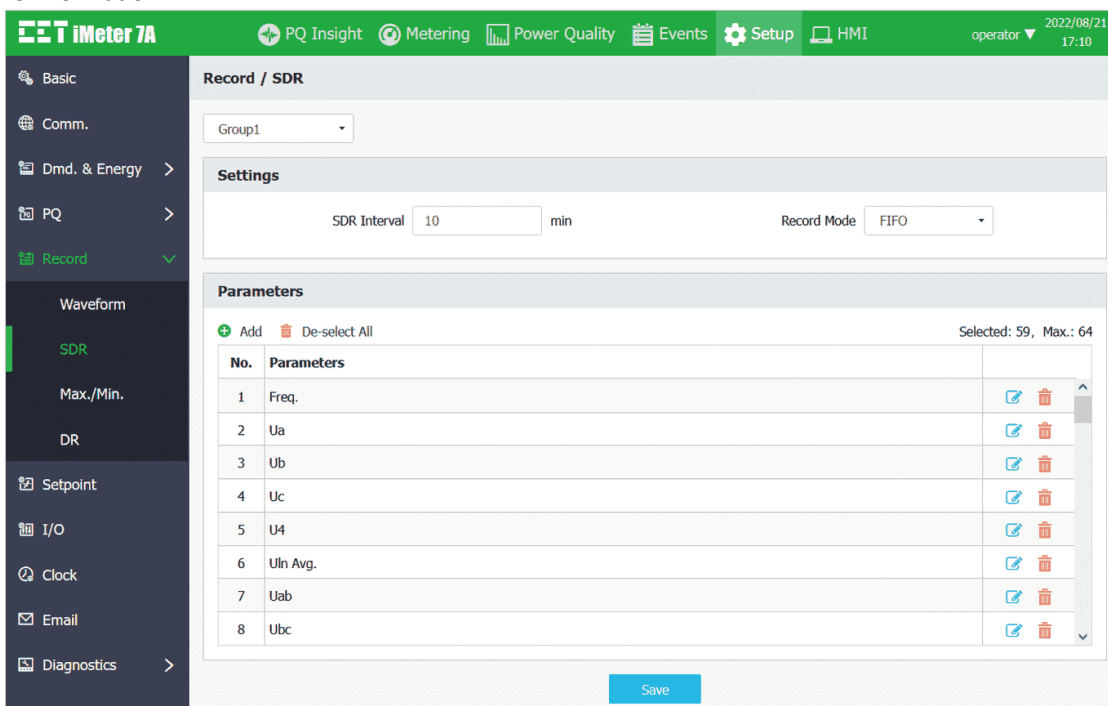

Figure 3-156 SDR Settings Interface

Click “+ Add” to add a batch of parameters or “De-select All” to remove all existing parameters. Click on the right-hand column to edit an existing parameter or to remove a particular parameter. Please refer to Appendix A for the available parameters for SDR.

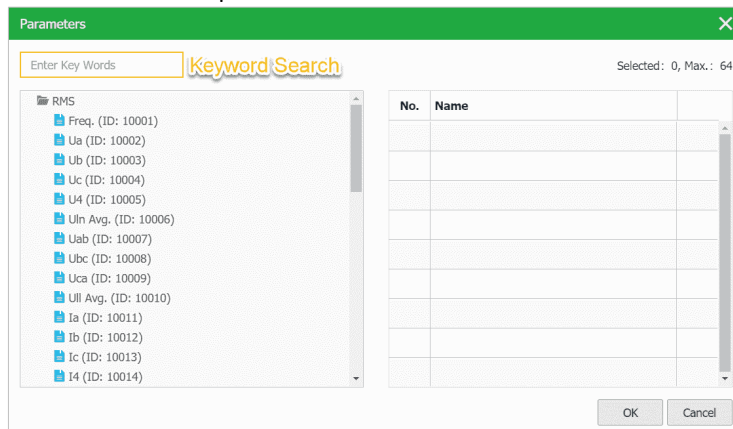

Figure 3-157 SDR Source Parameters Dialog Box

3.2.3.5.5.3 Max./Min.

The iMeter 7A supports 4 Max./Min Recorders of 20 parameters each. Please refer to Section 4.6.9 for the explanation of the Self-Read Time.

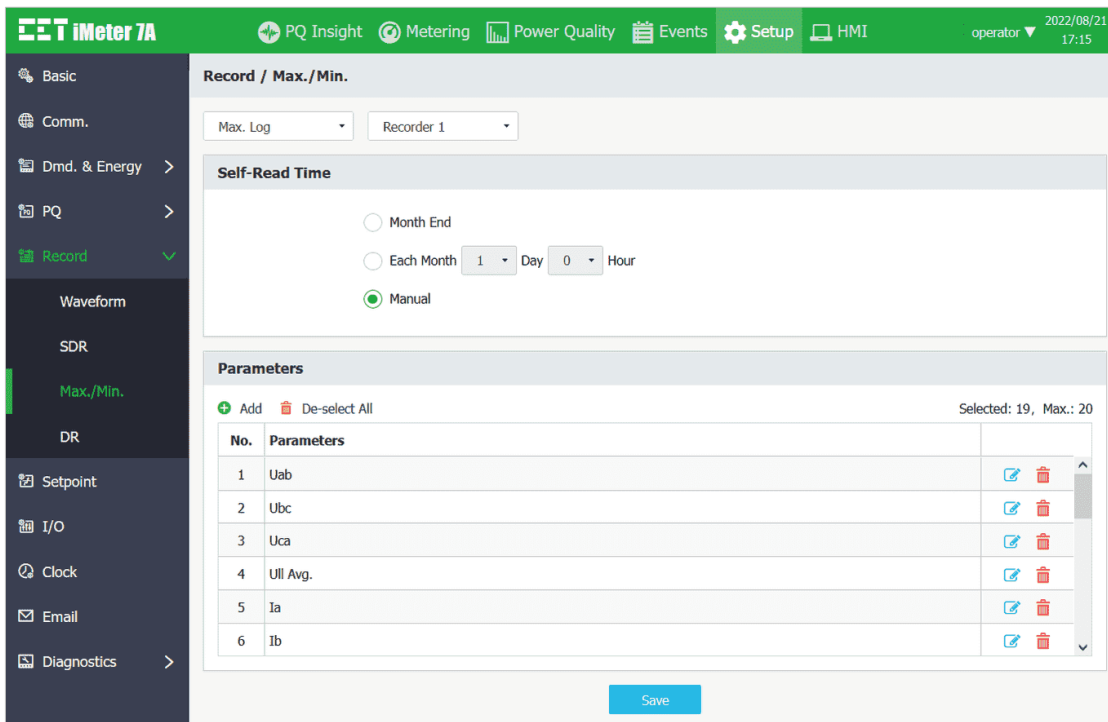

Figure 3-158 Max./Min. Setup Interface

Click “+ Add” to add a batch of parameters or “De-select All” to remove all existing parameters. Click on the right-hand column to edit an existing parameter or to remove a particular parameter. Please refer to Appendix A for the available parameters for Max./Min. Recorders.

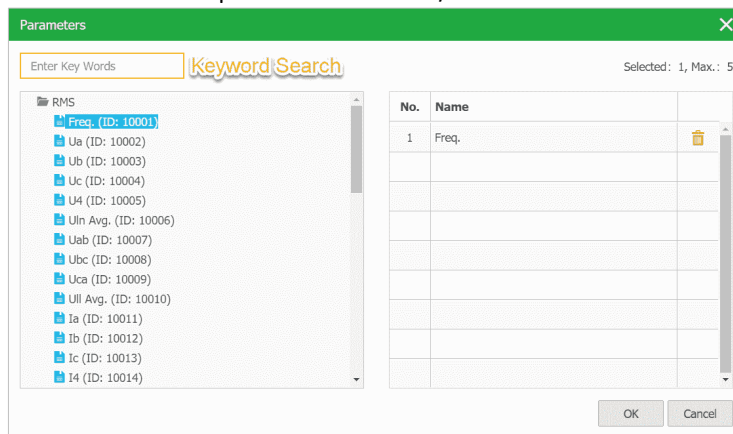

Figure 3-159 Max./Min. Source Parameters Dialog Box

3.2.3.5.5.4 DR

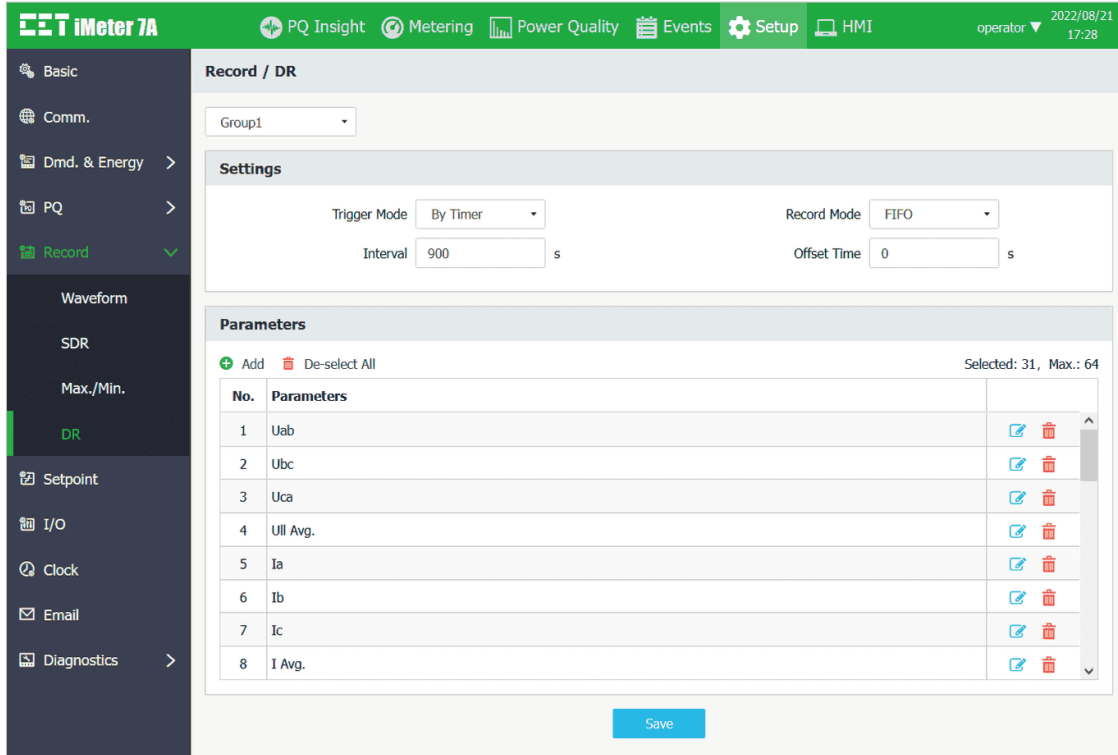

Figure 3-160 DR Setup Interface

Click “+ Add” to add a batch of parameters or “De-select All” to remove all existing parameters. Click on the right-hand column to edit an existing parameter or to remove a particular parameter. Please refer to Appendix A for the available parameters for Data Recorders.

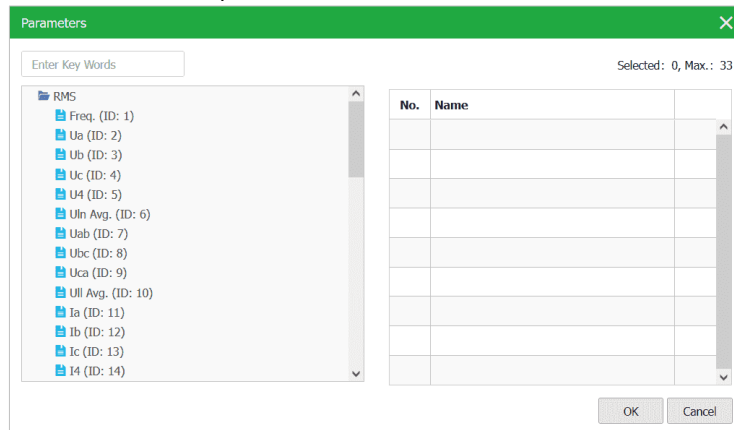

Figure 3-161 DR Source Parameters Dialog Box

3.2.3.5.6 Setpoint

Click **Setpoint** on the left-hand pane to configure the setup parameters for **Setpoint**.

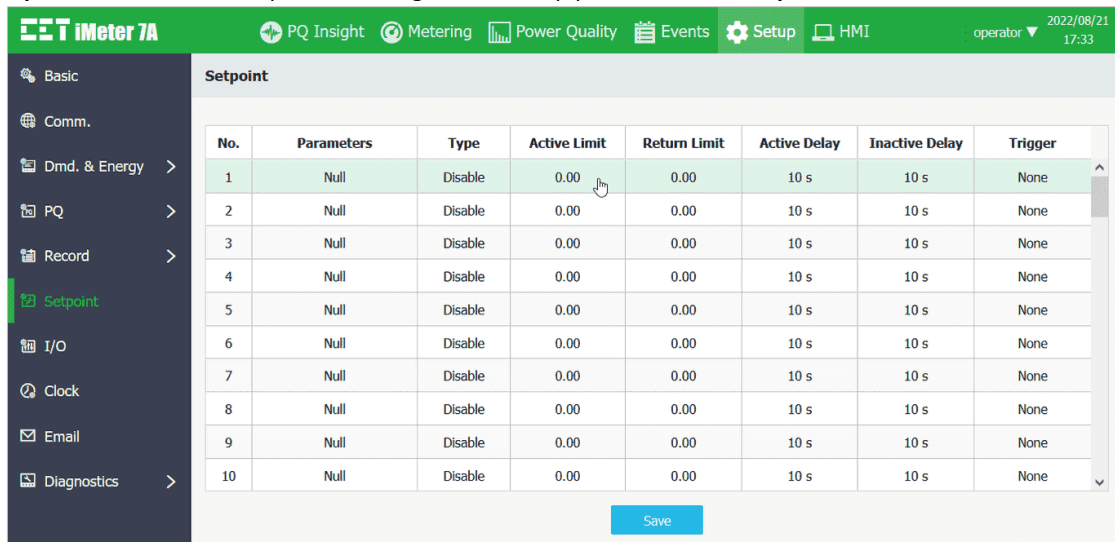

Figure 3-162 Setpoint Setup Interface

Click on a particular Setpoint and the **Setpoint Settings** dialog box appears.

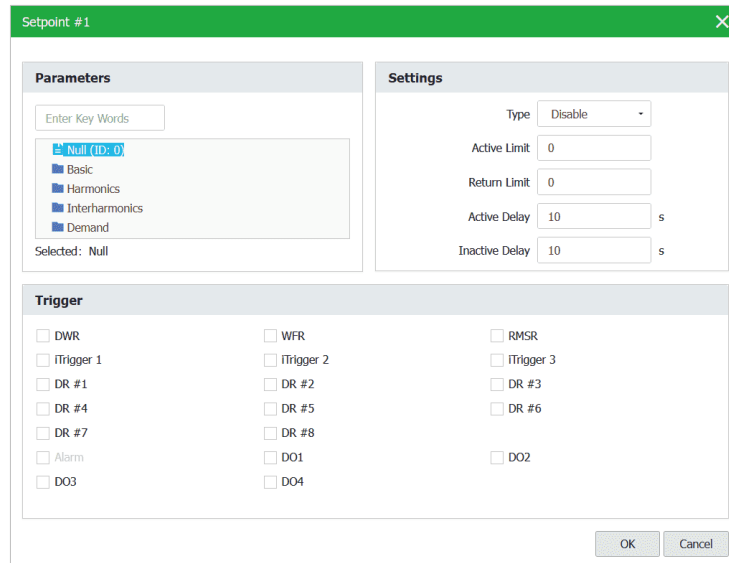

Figure 3-163 Setpoint Settings Dialog Box

3.2.3.5.7 I/O

Click **I/O** on the left-hand pane to configure the I/O parameters. Please refer to **Section 4.1** for more information.

- **DI**

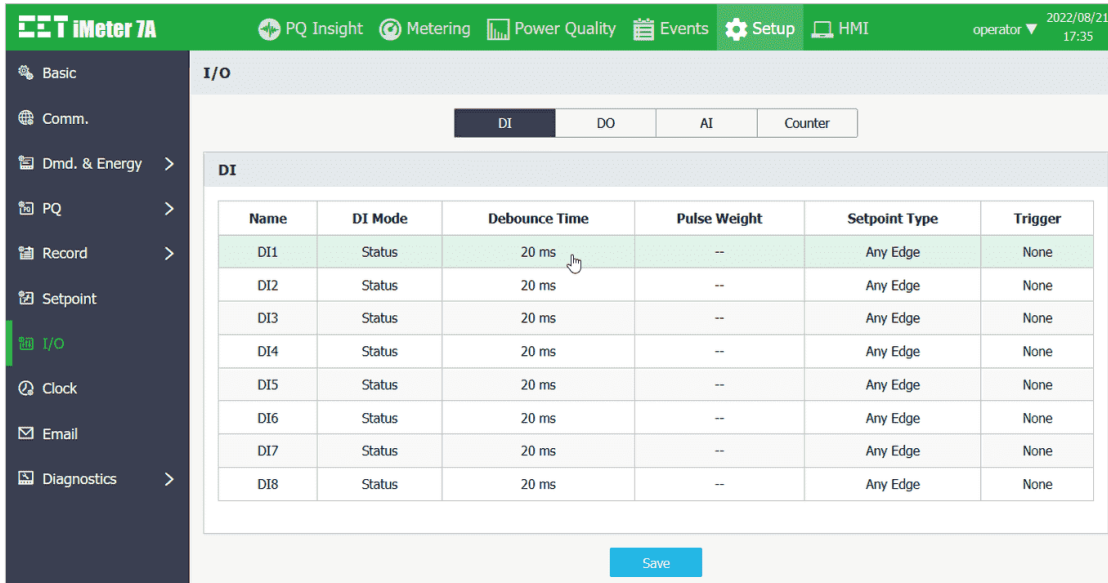

Figure 3-164 DI Setup Interface

Click on a particular DI and the **DI Settings** dialog box appears. Please refer to **Section 4.1.1** for more information.

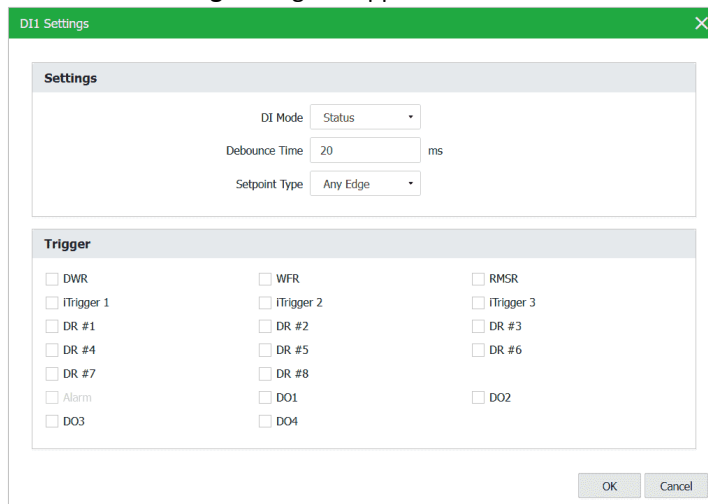

Figure 3-165 DI Settings Dialog Box

- **DO**

Click the **DO** tab at the top of the page and the following screen appears. Please refer to **Section 4.1.2** for more information.

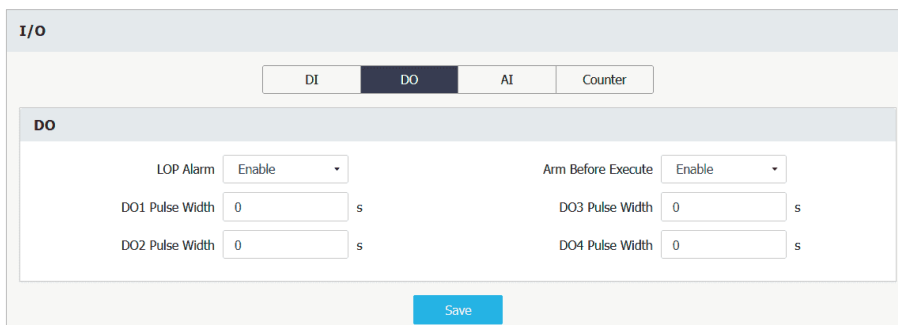

Figure 3-166 DO Setup Interface

- **Optional AI**

Click the **AI** tab at the top of the page and the following screen appears.

I/O

DI DO **AI** Counter

AI1

AI Type 4~20mA Zero Scale 400 Full Scale 2000

AI2

AI Type 4~20mA Zero Scale 400 Full Scale 2000

Save

Figure 3-167 AI Setup Interface

- **Counter**

Click the **Counter** tab at the top of the page and the following screen appears.

I/O

DI DO AI **Counter**

Counter Preset

DI1 0 DI2 0
DI3 0 DI4 0
DI5 0 DI6 0
DI7 0 DI8 0

Save

Figure 3-168 Counter Setup Interface

3.2.3.5.8 Clock

Click **Clock** on the left-hand pane to setup the **Date/Time** parameters.

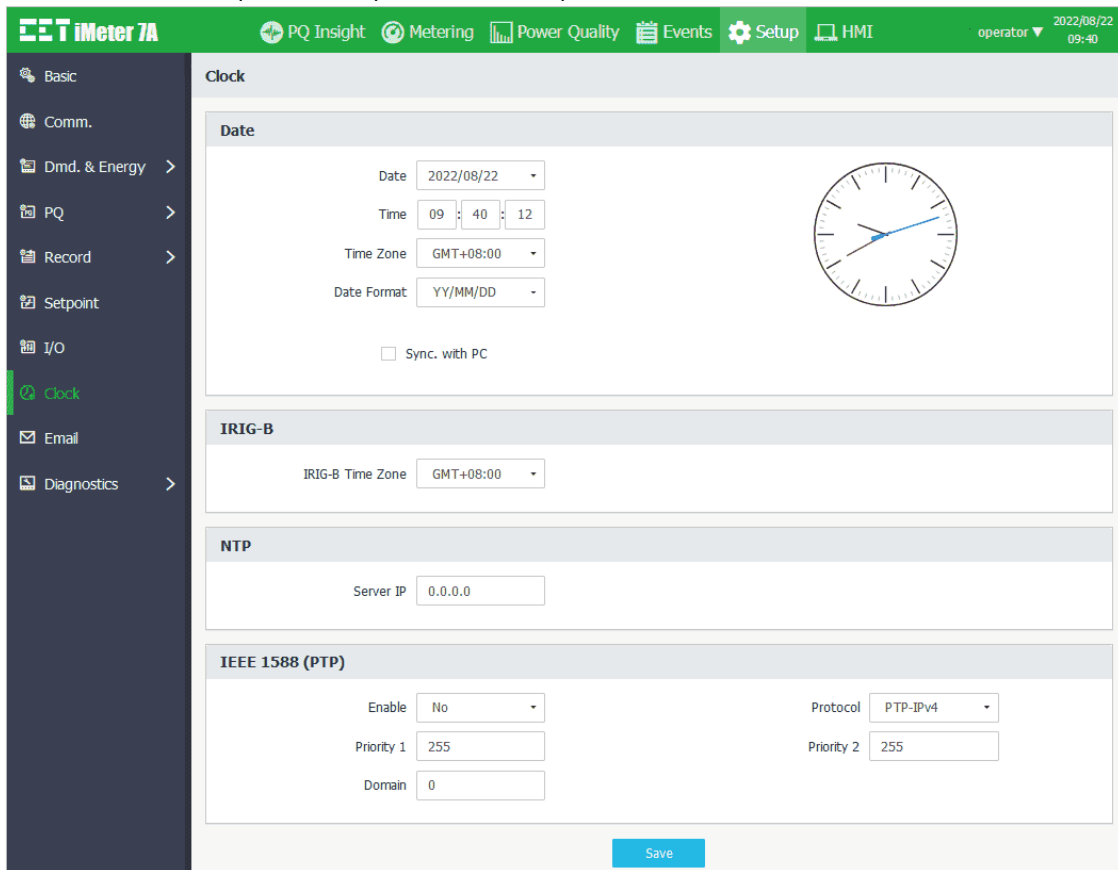

Figure 3-169 Clock Settings

3.2.3.5.9 Email

- **Settings** Please refer to **Section 4.10** for more information.

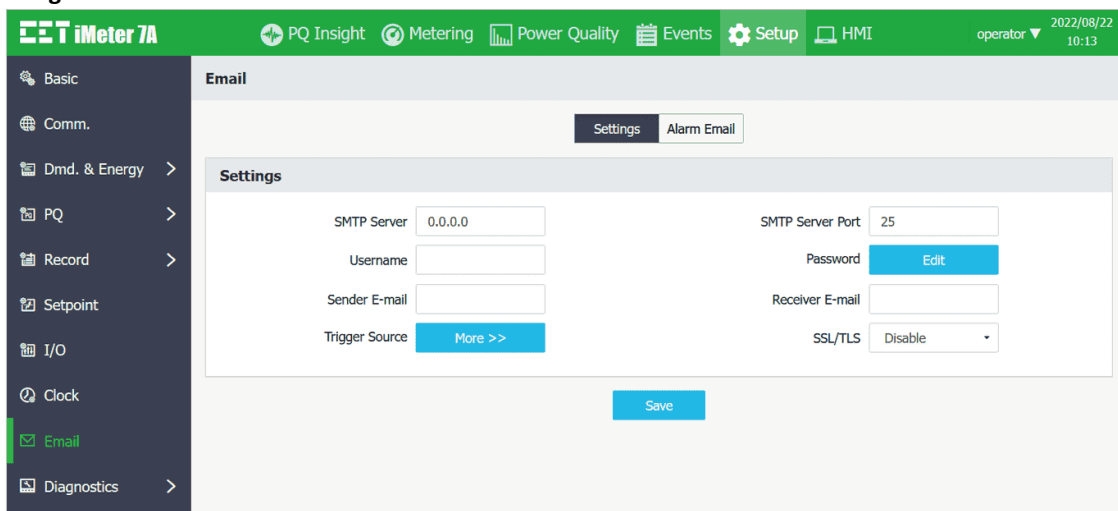

Figure 3-170 Alarm Email Setup Interface

Click **More >>** to open the Trigger Source dialog box and then select the event type that would trigger an alarm email.

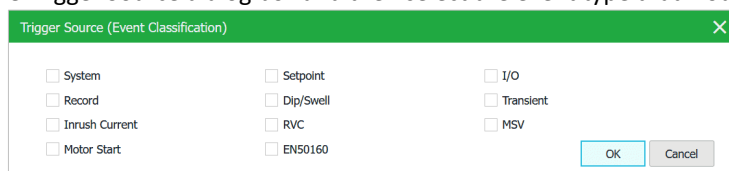

Figure 3-171 Trigger Source Dialog Box

- **Alarm Email** Click **Test** to send a test email to check the correctness of the **Alarm Email** configuration.

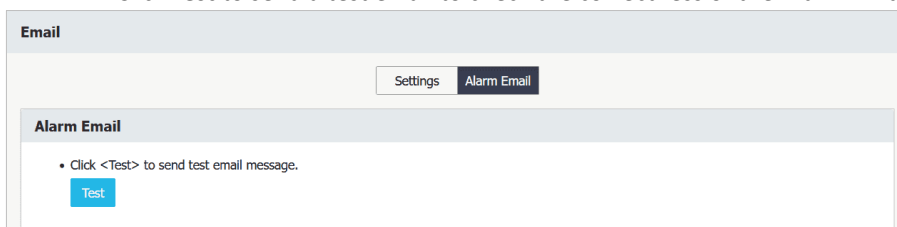

Figure 3-172 Alarm Email Test Interface

3.2.3.5.10 Diagnostics

Click **Diagnostics** on the left-hand pane to expand its sub-menu which consists of **Device & Site Info.**, **Maintenance**, **User Management** and **Advanced**.

3.2.3.5.10.1 Device & Site Info.

- **Device**

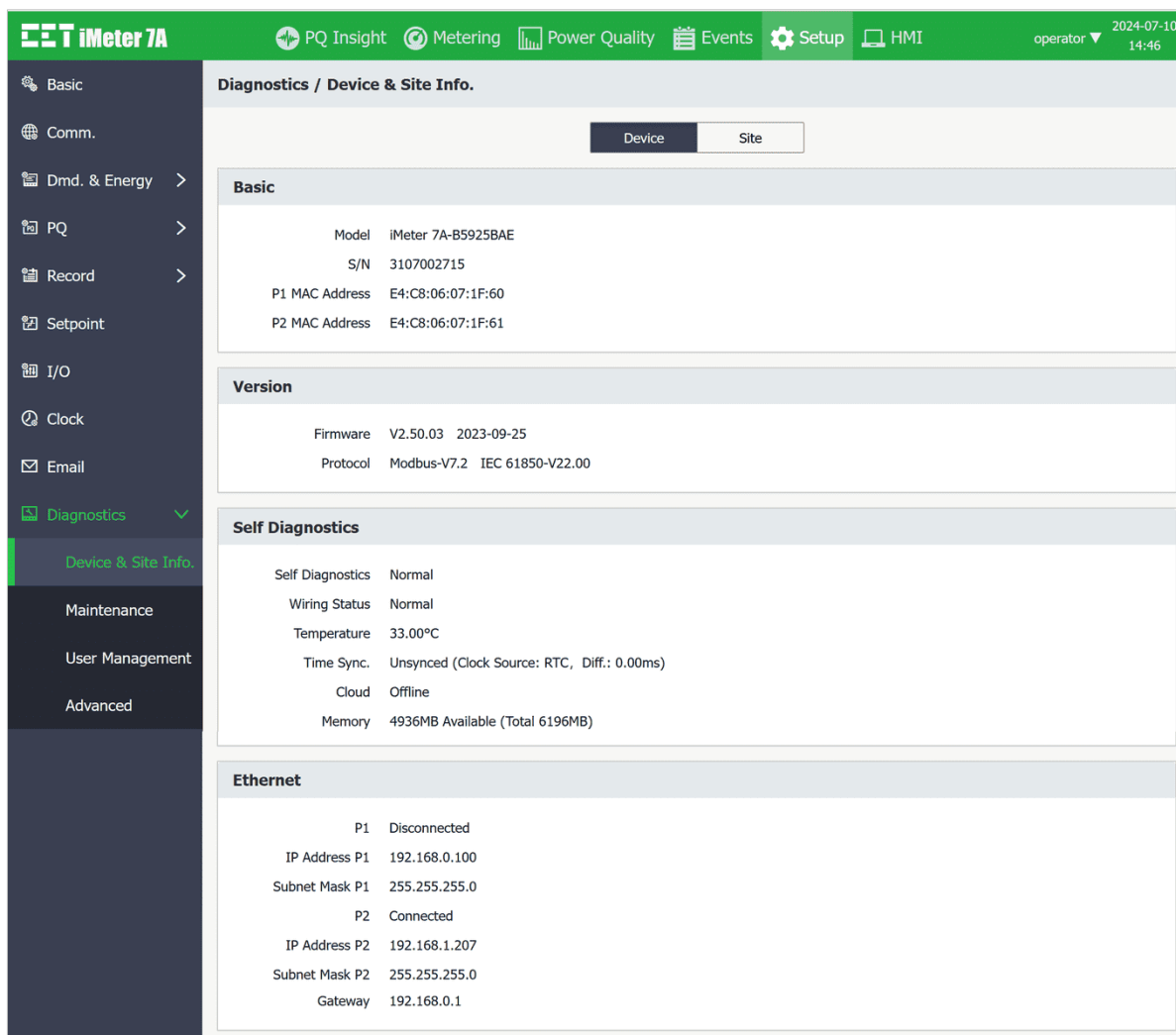

Figure 3-173 Device Info.

- Site

Diagnostics / Device & Site Info.

Device Site

Substation Information

Tag 1	devTag0
Tag 2	devTag1
Tag 3	devTag2
Tag 4	devTag3

Site Information

Tag 1	circuitTag 0
Tag 2	circuitTag 1
Tag 3	circuitTag 2
Tag 4	circuitTag 3
Tag 5	circuitTag 4
Tag 6	circuitTag 5
Tag 7	circuitTag 6
Tag 8	circuitTag 7
Tag 9	circuitTag 8
Tag 10	circuitTag 9

Save

Figure 3-174 Site Info. Setup Interface

3.2.3.5.10.2 Maintenance

Click **Maintenance** on the left-hand pane and the following screen appears which provides the options for **DO Control**, **Clear**, **Imp./Exp.** (Import/Export), **Upgrade** and **Restart**.

DO Control Perform Manual **DO Control** and **Reset all DOs to Normal**.

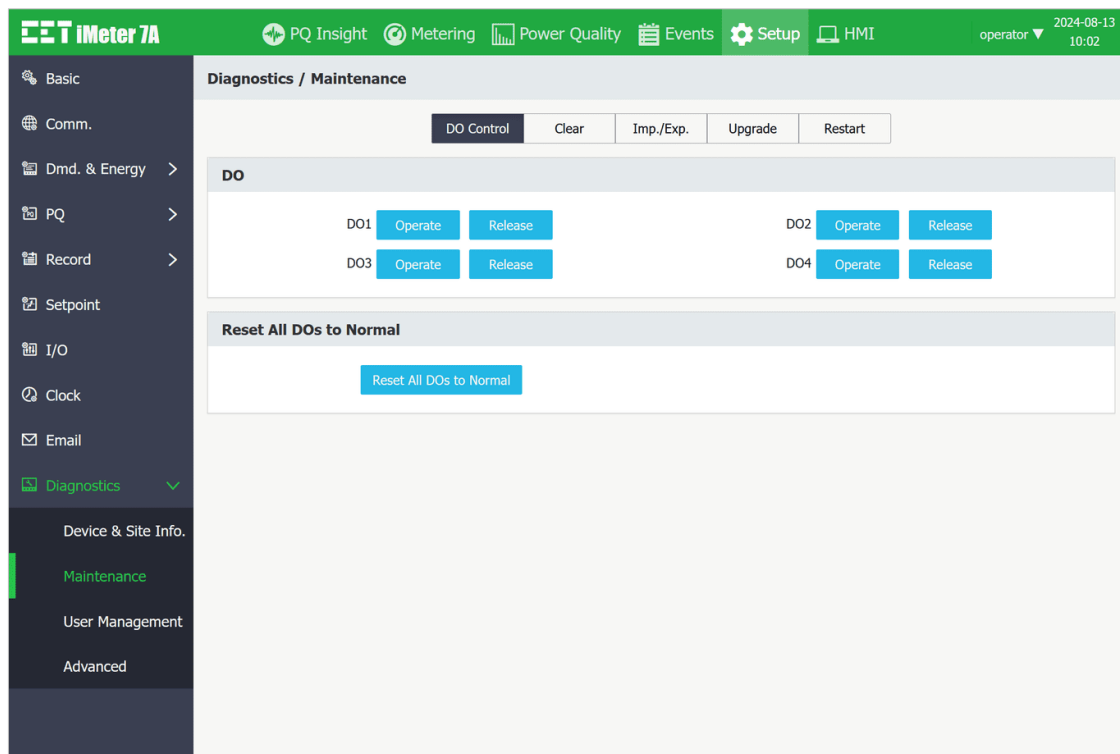

Figure 3-175 DO Control Interface

Depending on the **DO Pulse Width** setting, the DO may behave differently when it is operated. A zero **Pulse Width** means **Latched** operation while non-zero means **Pulsed** operation. For **Latched** operation, the DO will remain in the **Active** state when it's operated and will only return to the **Inactive** state when it's released. For **Pulsed** operation, the DO will return automatically from the **Active** state to the **Inactive** state after a duration that is equal to the non-zero **Pulse Width** setting, without requiring a **Release** operation. In addition, if a DO is already in a **Released** state, the **DO Release** command would fail and generate an error message as shown below.

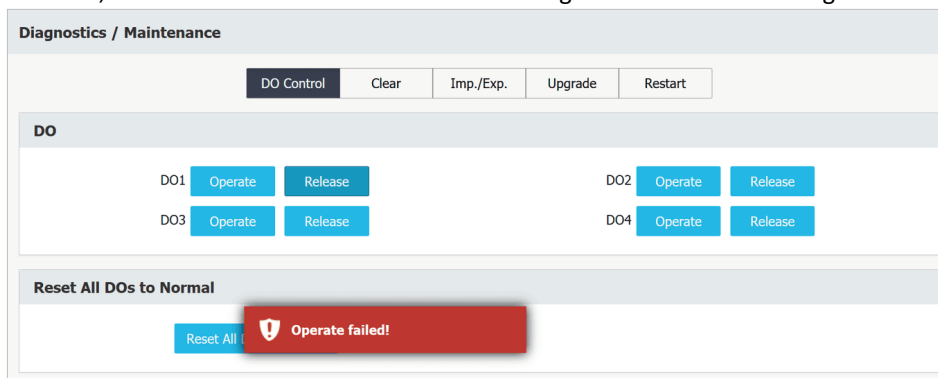

Figure 3-176 DO Release Command Failed

Clear

Click the Clear tab at the top of the page and the following screen appears which allows the users to perform the various Clear operation by group or individually.



Figure 3-177 Clear Operations Interface

Imp. /Exp. Import or Export the System Setup Parameters.

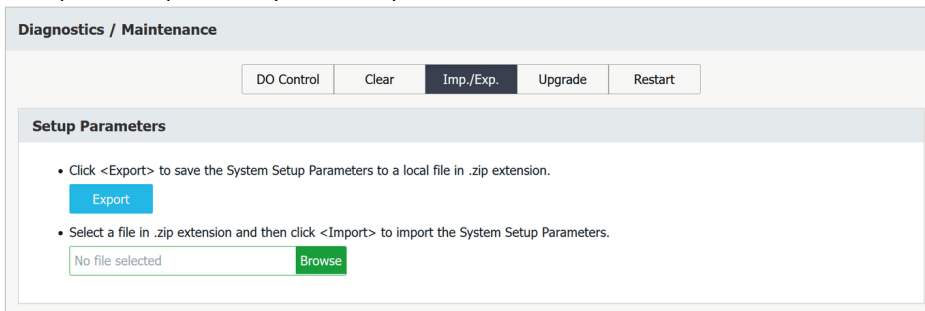

Figure 3-178 Imp./Exp. Interface

Upgrade Only a user with **Operator** authority can perform the Firmware Upgrade for iMeter 7A. It’s strongly recommended to clear the browser cache after upgrading the firmware for the normal display.

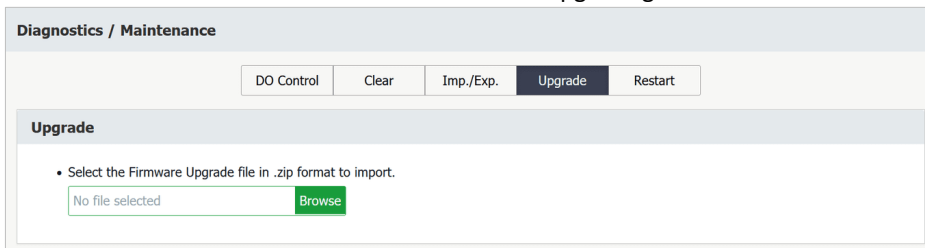

Figure 3-179 Upgrade Interface

Restart Click the **Restart** tab at the top of the page and the following screen appears which allows the meter to be restarted via the Web Interface.

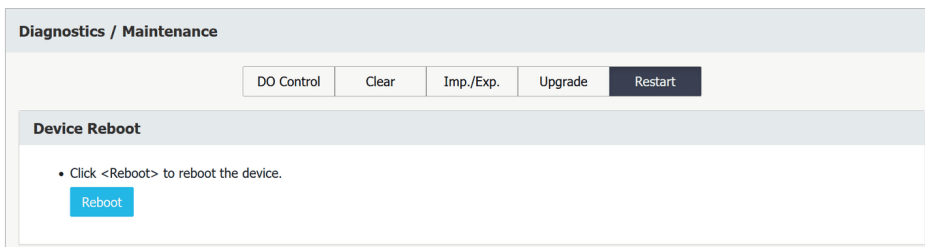

Figure 3-180 Restart Interface

3.2.3.5.10.3 User Management

The user with Operator authority can click to add a new user account or to remove an existing user account.

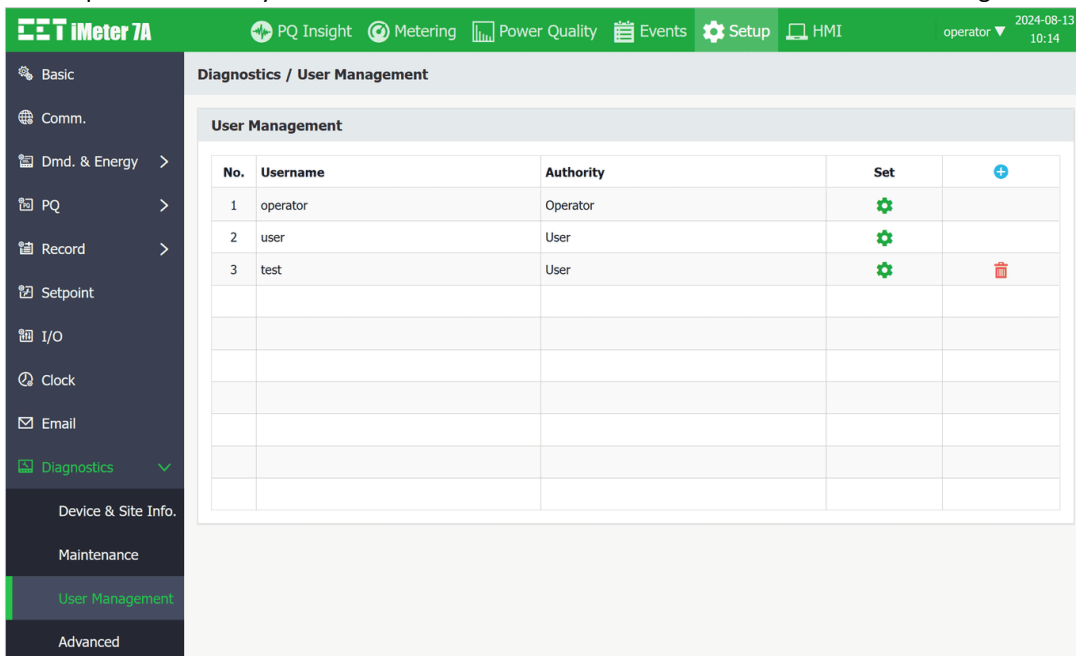

Figure 3-181 User Management Interface

3.2.3.5.10.4 Advanced

Click **Advanced** on the left-hand pane and the following screen appears which allows the **Advanced** parameters to be configured. Please consult with the qualified personnel before configuring these advanced parameters.

Diagnostics / Advanced

Time Format

COMTRADE

Modbus

Flagged Data

Setpoint Trigger

SDR

EN50160

Max. Log

Min. Log

IEEE519

COMTRADE

of Sampling Rates

Stored Values

Custom Label

PQ Disturbance

D/S RMS Update

Interruption Mode

D/S Max. Duration s

Swell Max. Magnitude %

Disturbance Direction

IEC 61850

Authentication

Timeout s

Password

Security Key

Quality Validity

Debug Setting

Debug Msg. Export

Debug Msg. Class

Web

Client Validate

Login Timeout min

Threshold

C.E. Voltage Threshold V

C.E. Current Threshold %

OT Threshold %

Transient Peak Threshold %*√2Un

Function Enable

HMI Security

Energy Short Rollover

Others

Energy Short Rollover

Flicker Algorithm

Firewall Flow Limit

Figure 3-182 Advanced Setup Interface

3.2.3.6 HMI

Click **HMI** at the **Title Bar** and the user can remotely access the Front Panel display if the Front Panel is illuminated. The user can click on the virtual buttons to operate the remote HMI. And the <↑>, <↓>, <←>, <→>, <Enter> and <Esc> buttons on the keyboard can also be used when the cursor is placed somewhere inside the display area of the remote HMI and the asterisk "*" appears.



Figure 3-183 HMI Interface

Chapter 4 Applications

4.1 Inputs and Outputs

4.1.1 Digital Input

The iMeter 7A comes standard with 4 or optional with 8 self-excited Digital Inputs that are internally wetted at 24 VDC with a sampling frequency of 1000Hz and programmable debounce. The iMeter 7A provides the following programmable functions for its Digital Inputs:

- 1) **Status Input** Status Inputs are typically used for status monitoring which can help prevent equipment damage, improve maintenance and track security breaches. The real-time statuses of the Digital Inputs are available on the Front Panel LCD Display, Web Interface as well as through communications. Changes in Digital Input status are stored as events in the SOE Log in 1 ms resolution.
- 2) **Pulse Counting** Pulse counting facilitates WAGES (Water, Air, Gas, Electricity and Steam) information collection with a fixed incremental value of 1 for each pulse received.
- 3) **Demand Sync Pulse** One of the Digital Inputs can be programmed to receive Demand Sync Pulse. Only one DI can be programmed as **DMD Sync**. For example, to set DI4 as Demand Sync Input, DI1 to DI3 must not be programmed as a **DMD Sync** input.
- 4) **Tariff Switching** Up to 3 Digital Inputs may be used to select to which of the 8 Tariffs the energy consumption should be accumulated. The 3 Digital Inputs (DI1 to DI3) represent 3 binary digits where Tariff 1=000, Tariff 2=001, ..., Tariff 8=111 where DI1 represents the least significant digit and DI3 represents the most significant digit. The **DI1 Function** setup register must first be programmed as a **Tariff Switch** before configuring DI2 with the same function. In other words, if DI1 is configured as a **Status Input** or **Pulse Counter** and DI2 is configured as a **Tariff Switch**, the TOU will continue to function based on the TOU Schedule.

The following table describes the DI's setup parameters:

Parameter	Definition	Options/*Default
Dlx Function	Each DI can be configured as a Status Input, Pulse Counter or DMD SYNC DI. Only DI1 to DI3 can be configured as Tariff Switch .	0=Status Input* 1=Pulse Counter 2=DMD Sync 3=Tariff Switch
Dlx Debounce	Specifies the minimum duration the DI must remain in the Active or Inactive state before a state change is considered to be valid.	1 to 9999 (ms) 20*
Dlx Setpoint Type¹	Specifies the transition edge, whether it's positive, negative or any, for a DI Setpoint to become active. The DI Setpoint Type is only used when a DI is configured as a Status Input.	Any Edge*, Positive, Negative
Dlx Pulse Weight	Specifies the incremental value for each received pulse. This is only used when a DI is configured as a Pulse Counter	1* to 1,000,000
Dlx Trigger	Specifies what output action a DI Setpoint will take when it becomes active. DI Setpoint is only valid when a DI is configured as a Status Input.	DO/DR/iTrigger/ WFR/DWR/RMSR

Table 4-1 DI Setup Parameters

Note:

1. The Dlx Setpoint Type only affects which edge would trigger the Waveform Recorder if configured.

4.1.2 Digital Output

The iMeter 7A comes standard with two or optional with four Form A Electromechanical Digital Outputs that are normally used for setpoint alarming, load control, or remote control applications. A normally closed (NC) Mechanical Relay output can be used for Power Failure Alarm by enabling LOP Alarm.

Digital Outputs on the iMeter 7A can be used in the following applications:

- 1) **Front Panel Control** Manually operated from the Front Panel. Please refer to the **Maintenance-> DO** in **Section 3.1.3.5.9** for a detailed description.
- 2) **Remote Control** Remotely operated over communications via an on-board web server or the PecStar® iEMS Integrated Energy Management System.
- 3) **Control Setpoint** Control setpoints can be programmed to trigger DO, DR, WFR/DWR/RMSR, iTrigger AND/OR Alarm Email upon becoming active. Please refer to **Section 4.5** for a detailed description.
- 4) **PQ Disturbance Setpoint** PQ Disturbance setpoint can be programmed to trigger DO, DR, WFR/DWR/RMSR, iTrigger AND/OR Alarm Email upon becoming active. Dips/Swells/Interruption setpoints can be programmed to trigger DO. Please refer to **Section 4.3.5** for a detailed description.
- 5) **ITIC/SEMI F47 Setpoint:** ITIC/SEMI F47 setpoint can be programmed to trigger DO AND/OR iTrigger upon becoming active. Please refer to **Section 4.3.19** for a detailed description.
- 6) **Transient Setpoint:** Transient setpoint can be programmed to trigger DO, WFR/DWR/RMSR, iTrigger AND/OR Alarm Email upon becoming active. Please refer to **Section 4.3.6** for a detailed description.
- 7) **RVC Setpoint** RVC setpoint can be programmed to trigger DO, WFR/DWR/RMSR, iTrigger AND/OR Alarm Email upon becoming active. Please refer to **Section 4.3.13** for a detailed description.
- 8) **Inrush Setpoint** Inrush Setpoint can be programmed to trigger DO, DR, WFR/DWR/RMSR, iTrigger AND/OR Alarm Email upon becoming active. Please refer to **Section 4.3.17** for a detailed description.
- 9) **Motor Startup Setpoint** Motor Startup Setpoint can be programmed to trigger DO, WFR/DWR/RMSR, iTrigger AND/OR Alarm Email upon becoming active. Please refer to **Section 4.4** for a detailed description.

DOs on the iMeter 7A have the following setup parameters:

Parameter	Definition	Options/Default*
LOP Alarm	Specifies if the Power Failure Alarm function is enabled. If the Output isn't programmed as Power Failure Alarm, it can be used as normal DO.	0=Disabled, 1=Enabled*
Arm Before Execute	Enable or disable the Arm Before Execute feature for the Alarm/DO	0=Disabled*, 1=Enabled
DOx (x=1 to 4) Pulse Width	Specifies the duration for which the DO will be active when a Remote Operate or Setpoint Trigger command is received to operate it.	0 to 6000 (x 0.1s), 0 (Latch Mode)*

Table 4-2 DO Setup Parameters

Since there are multiple ways to trigger the Digital Outputs on the iMeter 7A, a prioritized scheme has been developed to avoid conflicts between different applications. In general, Front Panel Control has the highest priority and can override other applications. Remote Control, Control Setpoint, Dip/Swell/Interruption Setpoint, ITIC/SEMI F47 Setpoint, Transient Setpoint, RVC Setpoint, Inrush Current Setpoint and Motor Start Setpoint share the same priority, meaning that they can all be programmed to control the same Digital Output. This scheme is equivalent to having an implicit Logical OR operation for the control of a Digital Output and may be useful in providing a generic alarm output signal. However, the sharing of a Digital Output is not recommended if the user intends to generate a control signal in response to a specific setpoint condition.

4.1.3 Energy Pulse Output (Optional)

The iMeter 7A optionally comes with two Solid State Relay Outputs for energy pulsing for kWh and kvarh pulsing. Energy Pulse Outputs are typically used for accuracy testing. Energy pulsing can be configured from the Front Panel, Web Interface or communications.

The following table illustrates the ranges and default values for the Energy Pulse parameters.

Parameters	Options/Default*	Parameters	Options/Default*
Pulse Constant ¹	1000*, 3200, 5000, 6400, 12800	E1/E2	See Table 4-5, N/A*

Table 4-3 Energy Pulse Parameters

Notes:

- The **Pulse Constant** can be configured as 1000/3200/5000/6400/12800 impulses per kWh or kvarh. It's important to understand that energy pulsing is always based on the secondary ratings as it would be impossible to generate the required number or pulses based on the primary ratings. The following table illustrates the recommended settings for the **Pulse Constant** based on $Z = V_{nominal} \times I_{nominal} \times 2$, where $V_{nominal}$ and $I_{nominal}$ are the secondary nominal Voltage and Current ratings, respectively. In general, one would use a higher **Pulse Constant** for a smaller Z value (i.e. a smaller $V_{nominal}$ and $I_{nominal}$) in an accuracy testing situation to reduce the test time.

Z	Energy Pulse Constant	Default	Min. Interval
≤1000	1000/3200/5000/6400/12800	1000	160ms
≤2000	1000/3200/5000/6400	1000	
≤2600	1000/3200/5000	1000	
≤4000	1000/3200	1000	
>13000	1000	1000	

Table 4-4 Recommended Settings for Energy Pulse Constant

- The following table illustrates the available options for the Energy Pulse parameters.

ID	Parameter	ID	Parameter
1	kWh Total	10	kvarh Total
2	kWh Imp.	11	kvarh Imp.
3	kWh Exp.	12	kvarh Exp.
4	kWh Total Fund.	13	kvarh Total Fund.
5	kWh Imp. Fund.	14	kvarh Imp. Fund.
6	kWh Exp. Fund.	15	kvarh Exp. Fund.
7	kWh Total TH	16	kvarh Total TH
8	kWh Imp. TH	17	kvarh Imp. TH
9	kWh Exp. TH	18	kvarh Exp. TH

Table 4-5 Available options for Energy Pulse

4.1.4 Analog Input (Optional)

The iMeter 7A comes optionally with two Analog Inputs which can be programmed as 0mA to 20mA or 4mA to 20mA input. There are 3 setup parameters:

Parameters	Definition	Options/Range, Default*
Type	Select between 0-20mA or 4-20mA input	4~20mA*, 0~20mA
Zero Scale	This value corresponds to the minimum Analog Input of 0 mA (for 0-20mA Input) or 4 mA (for 4-20mA input).	-999,999 ~ +999,999, 400*
Full Scale	This value corresponds to the maximum Analog Input of 20 mA.	-999,999 ~ +999,999, 2000*

Table 4-6 AI Setup Parameters

For example, to measure the oil temperature of a transformer, connect the outputs of the temperature sensor to the AI terminals of the iMeter 7A. The temperature sensor outputs 4mA when the temperature is -25°C and 20mA when the temperature is 100°C. As such, the **Type** parameter should be programmed as **4-20mA**. The **AI Full Scale** parameter should be programmed with the value 100, and the **AI Zero Scale** parameter should be programmed with the value -25. Therefore, when the output of the sensor is 20mA, the reading will be 100.00°C. When the output is 4mA, the reading will be -25.00°C. When the output is 12mA, the reading will be $(100^{\circ}\text{C} - (-25^{\circ}\text{C})) \times (12\text{mA} - 4\text{mA}) / (20\text{mA} - 4\text{mA}) + (-25^{\circ}\text{C}) = 37.50^{\circ}\text{C}$.

4.1.5 RTD Input (Optional)

The iMeter 7A optionally provides two RTD Inputs for temperature measurements. The PT100 sensors are not included. The 2-wire outputs of the PT100 sensor are connected to the RTD Input of the iMeter 7A if so equipped. The iMeter 7A can provide accurate temperature monitoring with the optional RTD inputs for measuring the temperature of the Neutral Conductor, Transformer or other equipment. There is an RTD Compensation register for each channel which can be used to compensate the measurement accuracy, and the compensation can be set according to the formula:

$$\text{RTD Compensation} = 0.29 \times L \quad \text{where } L \leq 8 \text{ is the PT100 sensor's cable length in m}$$

4.2 Power, Energy and Demand

4.2.1 Basic Measurements

The iMeter 7A provides the following basic measurements (@ 1-second update rate) which are available through the Front Panel, Web Interface or communications.

- 3-phase U, I, P, Q, S, PF, Phase Angles as well as U4, I4, Ung, IR and Frequency
- kWh, kvarh Import/Export/Net/Total and kVAh Total

4.2.2 High-Speed Measurements

The iMeter 7A provides the following high-speed measurements which are available through communications.

- 3-phase U, I, P, Q, S and PF as well as U4 and I4 @ ½ cycle
- Frequency @ 1 cycle

4.2.3 Energy Measurements

The iMeter 7A provides Energy measurements for the following parameters shown in Table 4-7 with a resolution of 0.1 and a maximum value of ±100,000,000,000,000.0. When the maximum value is reached, the energy registers will automatically roll over to zero. The energy can be reset manually through the Front Panel, on-board Web Interface or communications. Besides, the energy registers can be preset to user-defined values through the Web Interface or via communications.

The iMeter 7A provides the following energy measurements:

3-phase Total		
RMS kWh Import	RMS kvarh Import	kVAh Total
RMS kWh Export	RMS kvarh Export	
RMS kWh Net	RMS kvarh Net	
RMS kWh Total	RMS kvarh Total	
Fundamental kWh Import	Fundamental kvarh Import	
Fundamental kWh Export	Fundamental kvarh Export	
Harmonic kWh Import	Harmonic kvarh Import	
Harmonic kWh Export	Harmonic kvarh Export	
kWh Import H02	kvarh Import H02	
...	...	
kWh Import H63	kvarh Import H63	
kWh Export H02	kvarh Export H02	
...	...	
kWh Export H63	kWh Export H63	
Per-phase		
kWh Import	kvarh Import	kVAh Total
kWh Export	kvarh Export	
kWh Net	kvarh Net	
kWh Total	kvarh Total	

Table 4-7 Energy Measurements

4.2.4 Demand Measurements

4.2.4.1 Present and Predicted Demand

iMeter 7A provides the predicted demand for pre-alarming and helps users to reduce demand consumption by predicting the demand at the end of the present period based on the current real-time power consumption.

The iMeter 7A provides the following Present Demand and Predicted Demand parameters:

	Present Demand	Predicted Demand
Voltage	Ua, Ub, Uc, UIn Avg., U4, Uab, Ubc, Uca, UII Avg.	Ua, Ub, Uc, UIn Avg., U4, Uab, Ubc, Uca, UII Avg.
Current	Ia, Ib, Ic, I Avg., I4	Ia, Ib, Ic, I Avg., I4
Frequency	Frequency	Frequency
Power	Pa Import/Export, Pb Import/Export, Pc Import/Export, Total P Import/Export, Qa Import/Export, Qb Import/Export, Qc Import/Export, Total Q Import/Export, Sa, Sb, Sc, Total S	Pa Import/Export, Pb Import/Export, Pc Import/Export, Total P Import/Export, Qa Import/Export, Qb Import/Export, Qc Import/Export, Total Q Import/Export, Sa, Sb, Sc, Total S
PF	PFa, PFb, PFc, PF Total	PFa, PFb, PFc, PF Total
Harmonics	Ua (Uab) THD/TOHD/TEHD, Ub (Ubc) THD/TOHD/TEHD, Uc (Uca) THD/TOHD/TEHD, U4 THD/TOHD/TEHD, Ia Fund. /THD/TOHD/TEHD/K-Factor, Ib Fund. /THD/TOHD/TEHD/K-Factor, Ic Fund. /THD/TOHD/TEHD/K-Factor, I4 Fund. /THD/TOHD/TEHD/K-Factor	Ia Fund., Ib Fund., Ic Fund.
Deviation	Ua Deviation/Over Deviation/Under Deviation, Ub Deviation/Over Deviation/Under Deviation, Uc Deviation/Over Deviation/Under Deviation, Uab Deviation/Over Deviation/Under Deviation, Ubc Deviation/Over Deviation/Under Deviation, Frequency Deviation	--
Unbalance	U0 Unbalance, U2 Unbalance, I0 Unbalance, I2 Unbalance	--

Table 4-8 Present Demand and Predicted Demand Parameters

4.2.4.2 Max. Demand

iMeter 7A also provides the Max. Demand of This Month and Last Month or Since Last Reset and Before Last Reset according to the **Self-Read Time** setup parameter. The Max. Demand of This Month (or Since Last Reset) is transferred to the Max. Demand of Last Month (Before Last Reset) and then reset each month at the **Self-Read Time** or after a manual reset.

The iMeter 7A records the Max. Demand for This Month (Since Last Reset) and Last Month (Before Last Reset) with timestamps for the parameters listed in Table 4-9. The Max. Demand can be accessed from the Front Panel, Web Interface or communications. The Max. Demand of This Month can be reset manually via communications. The iMeter 7A provides the following Max. Demand parameters:

	Max. Demand Measurements (with Timestamp)
Power	Total P Import, Total P Export, Total Q Import, Total Q Export
Current	Ia, Ib, Ic, Ia Fund., Ib Fund., Ic Fund.

Table 4-9 Max. Demand Measurements

4.2.4.3 Max./Min Values Per Demand Period

In addition, the iMeter 7A provides the max./min. value per demand period of the following measurements which can be retrieved through communications.

	Max./Min. Measurements Per Demand Period
Voltage	Ua, Ub, Uc, Uln Avg., U4, Uab, Ubc, Uca, Ull Avg.
Current	Ia, Ib, Ic, I Avg., I4
Frequency	Frequency
Power	Pa Import/Export, Pb Import/Export, Pc Import/Export, Total P Import/Export, Qa Import/Export, Qb Import/Export, Qc Import/Export, Total Q Import/Export, Sa, Sb, Sc, Total S
PF	PFa, PFb, PFc, PF Total
Harmonics	Ua (Uab) THD/TOHD/TEHD, Ub (Ubc) THD/TOHD/TEHD, Uc (Uca) THD/TOHD/TEHD, U4 THD/TOHD/TEHD, Ia Fund. /THD/TOHD/TEHD/K-Factor, Ib Fund. /THD/TOHD/TEHD/K-Factor, Ic Fund. /THD/TOHD/TEHD/K-Factor, I4 Fund. /THD/TOHD/TEHD/K-Factor
Deviation	Ua Deviation/Over Deviation/Under Deviation, Ub Deviation/Over Deviation/Under Deviation, Uc Deviation/Over Deviation/Under Deviation, Uab Deviation/Over Deviation/Under Deviation, Ubc Deviation/Over Deviation/Under Deviation, Frequency Deviation
Unbalance	U0 Unbalance, U2 Unbalance, I0 Unbalance, I2 Unbalance

Table 4-10 Max./Min. Values Per Demand Period

4.2.4.4 Demand Setup Parameter

The iMeter 7A provides the following setup parameters.

Setup Parameter	Definition	Options/*Default
Sync. Mode	SLD – Internally synchronized to the meter’s real-time clock. Sync. DI – Externally synchronized to a DI that has been programmed as a Demand Sync Input by setting the DI Function as “DMD Sync”.	0 = SLD* 1 = Sync. DI
Demand Period	1 to 60 minutes. For example, if the # of Sliding Windows is set as 1 and the Demand Period is 15, the demand cycle will be 1x15=15min.	1 to 60 min 15*
# of Sliding Windows	The number of Sliding Windows.	1 to 15, 1*
Self-Read Time	The Self-Read Time allows the user to specify the time and day of the month for the Max. Demand Self-Read operation. The Self-Read Time supports three options: <ul style="list-style-type: none"> • A zero value means that the Self-Read will take place at 00:00 of the first day of each month. • A non-zero value means that the Self-Read will take place at a specific time and day based on the formula: Self-Read Time = Day * 100 + Hour where 0 ≤ Hour ≤ 23 and 1 ≤ Day ≤ 28. For example, the value 1512 means that the Self-Read will take place at 12:00pm on the 15th day of each month. • A 0xFFFF value will disable the Self-Read operation and replace it with Manual operation. A manual reset will cause the Max. Demand of This Month to be transferred to the Max. Demand of Last Month and then reset. The terms This Month and Last Month will become Since Last Reset and Before Last Reset. 	0xFFFF*
Predicted Response	The Predicated Response shows the speed of the predicted demand output. A value between 70 and 99 is recommended for a reasonably fast response. Specify a higher value for higher sensitivity.	70 to 99, 70*

Table 4-11 Demand Setup Parameters

4.3 Power Quality Parameters

4.3.1 Power Frequency and Freq. Deviation

The iMeter 7A is capable of measuring **Frequency** accurately to $\pm 0.003\text{Hz}$. The measurement range is $\pm 10\%$ of f_{nominal} , which is 40Hz to 60Hz for 50Hz system and 48 Hz to 72Hz for 60Hz system.

The measurement method of **Frequency** is in accordance with **Section 5.1 of IEC 61000-4-30 Ed. 3.1 Standard** for Class A performance. The iMeter 7A also computes **Freq. Deviation** as per below:

$$\text{Freq. Deviation} = f - f_{\text{nominal}}$$

where f_{nominal} is the Nominal Frequency

The **Freq. Deviation** measurement can be accessed through Front Panel, On-board Web Server or through Communications.

4.3.2 Magnitude of the Supply Voltage

The measurement method of the **Magnitude of the Supply Voltage** is in accordance with **Section 5.2 of IEC 61000-4-30 Ed. 3.1 Standard** for Class A performance. The measurement method is not intended for the detection and measurement of disturbances such as **Dip, Swell, Voltage Interruption** and **Transient**. The RMS value includes voltage-related measurements such as **Harmonic, Interharmonic, Mains Signalling**, etc.

4.3.3 Magnitude of Current

As per **IEC 61000-4-30 Ed. 3.1 Standard** for Class A performance, the Current measurements (Waveform, Harmonic and Interharmonic) are useful as a supplement to voltage measurements.

- *The basic measurement shall be the RMS value of the current magnitude over a 10/12-cycle time interval for a 50/60 Hz power system.*
- *The boundaries of any current measurement interval shall be determined by, and identical to, the boundaries of the interval for the corresponding voltage channel.*

4.3.4 Flicker

Flicker is a recurrent variation of light intensity of lamps caused by load change which produces a voltage drop across a system's impedance. The iMeter 7A provides the flicker measurements in accordance with **Section 5.3 of IEC 61000-4-30 Ed. 3.1 Standard** for Class A performance (where **IEC 61000-4-15 Standard** applies).

4.3.4.1 Configuration

To correctly evaluate flicker measurements, it is necessary to select the lamp-model voltage (i.e., **Flicker Curve**, 120V or 230V) used in the flicker measurement algorithm according to the nominal voltage.

4.3.4.2 Measurement

The iMeter 7A provides the following Flicker measurements.

- Short-term flicker severity (Pst) measured over a 10-minute interval.
- Long-term flicker severity (Plt) calculated from a rolling sequence of 12 Pst according to the following formula:

$$Plt = \sqrt[3]{\sum_{i=1}^{12} \frac{Pst_i^3}{12}}$$

After two hours measuring, the first Plt will be calculated. As from two hours Plt is calculated every 10 minutes.

The Pst and Plt measurements can be accessed through Front Panel, Web Server or through Communications.

Pst/Plt values above 1.00 are generally considered a potential issue. During the development and testing phase, 1.00 was established as the value where half of all people tested indicated that the flicker level was annoying.

4.3.5 PQ Disturbance – Dip/Swell/Interruption

The iMeter 7A supports the detection of the **Supply Voltage Dips, Swells** and **Interruptions** using a method that is in accordance with **Section 5.4 of IEC 61000-4-30 Ed. 3.1 Standard** for Class A performance.

The iMeter 7A provides Dips/Swells/Interruptions detection for voltage quality monitoring on a per-phase basis, which supports multiple triggers at the same time, including **DR, WFR/DWR/RMSR, DO, iTrigger, SOE** and **Alarm Email**. The timestamp, duration and Magnitude of per phase voltage of each Dip/Swell/Interruption would be recorded by the meter.

4.3.5.1 Dips/Swells/Interruptions Detection

As per IEC 61000-4-30 Ed. 3.1:

Voltage Swell Detection

On polyphase systems a Swell begins when the $U_{rms(1/2)}$ voltage of one or more channels rises above the Swell Threshold and ends when the $U_{rms(1/2)}$ voltage on all measured channels is equal to or below the Swell Threshold minus the Hysteresis voltage.

Voltage Dip Detection

On polyphase systems a Dip begins when the $U_{rms(1/2)}$ voltage of one or more channels is below the Dip Threshold and ends when the $U_{rms(1/2)}$ voltage on all measured channels is equal to or above the Dip Threshold plus the Hysteresis voltage.

Voltage Interruption Detection

On polyphase systems, a voltage interruptions begins when the $U_{rms(1/2)}$ voltage of all channels fall below the voltage interruption threshold, and ends when the $U_{rms(1/2)}$ voltage on any one channel is equal to, or greater than, the voltage interruption threshold plus the hysteresis.

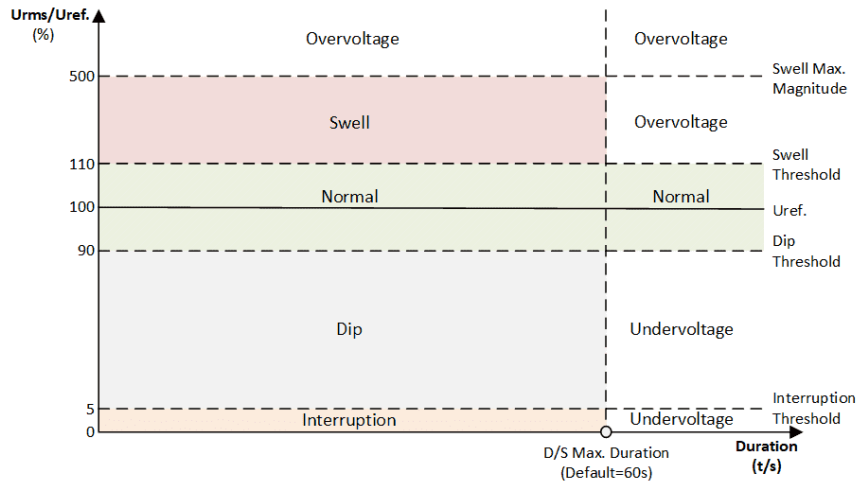

Figure 4-1 PQ Disturbance Detections

Swells and Dips are described as short-duration variations, under- and over-voltages are described as long-duration variations. When the voltage drops below a specified percentage of the nominal voltage (usually 5% or less), it is called an interruption.

• **Swell**

Swell detection starts when the following criteria are satisfied simultaneously:

1. The RMS voltage (U_{rms}) of one or more channels rises above the **[Swell Threshold (Default: 110%) x U_{ref} .]**
2. All 3 channels' U_{rms} are below the **[Swell Max. Magnitude (Default: 500%) x U_{ref} .]**
3. **Duration** is shorter than **D/S Max. Duration (Default: 60s)**

Swell detection ends when all 3 channels' U_{rms} fall below the value of **[Swell (Threshold - Hysteresis) x U_{ref} .]**

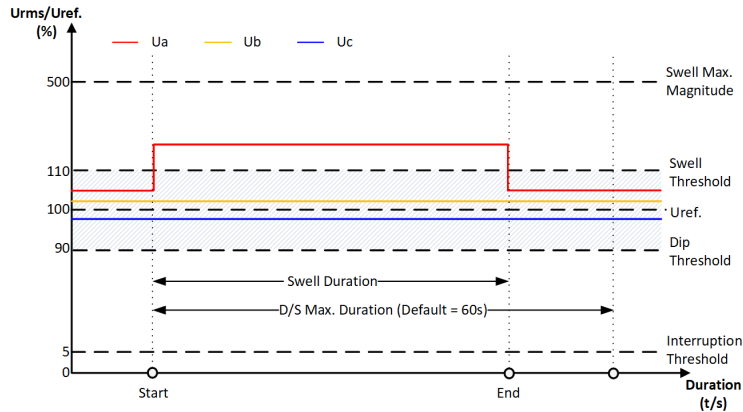

Figure 4-2 Swell Detection Criteria

• **Overvoltage**

Overvoltage will be detected when any of the following criteria are satisfied:

1. One or more channels voltage U_{rms} rise above the **[Swell Max. Magnitude (Default: 500%) x U_{ref} .]**

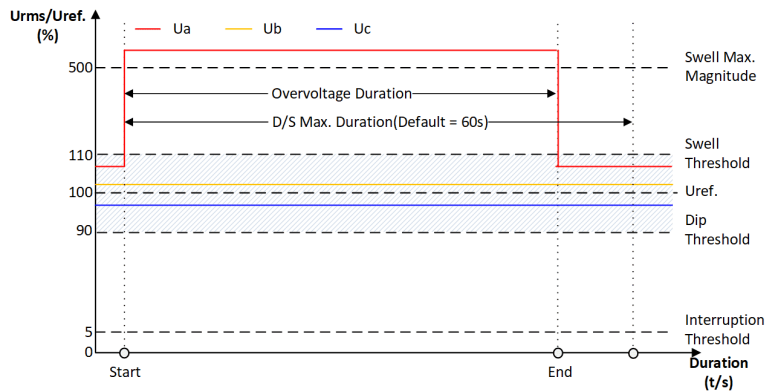

Figure 4-3 Overvoltage Detection Criteria 1

2. The U_{rms} of one or more channels voltage is above the **[Swell Threshold x U_{ref} .]** and duration is longer than the **D/S Max. Duration (Default: 60s)**

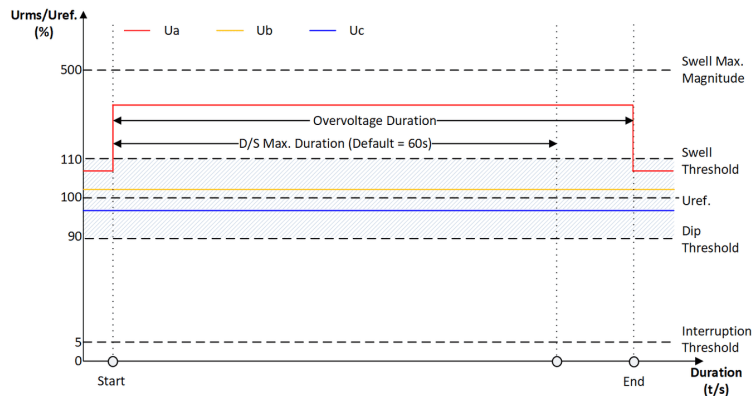

Figure 4-4 Overvoltage Detection Criteria 2

Overvoltage detection ends when all 3 channels voltage falls below the value of **[Swell (Threshold - Hysteresis) x U_{ref} .]**

• **Dip**

Dip detection starts when the following criteria are satisfied simultaneously:

1. The voltage U_{rms} of one or more channels falls below the [**Dip Threshold (Default: 90%) x U_{ref} .**] but exceeds the [**Interruption Threshold (Default: 5%) x U_{ref} .**].
2. **Duration** is shorter than **D/S Max. Duration (Default: 60s)**.

Dip detection ends when all 3 channels voltage exceed [**Dip (Threshold + Hysteresis) x U_{ref} .**].

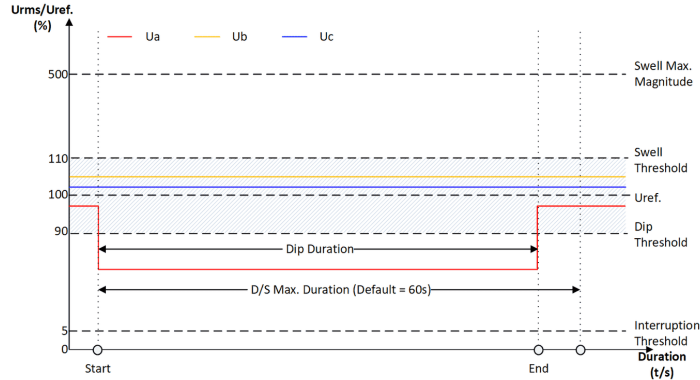

Figure 4-5 Dip Detection Criteria

• **Interruption**

Interruption detection starts when the following criteria are satisfied simultaneously:

1. All 3 channels voltage U_{rms} falls below the [**Interruption Threshold (Default: 5%) x U_{ref} .**].
2. **Duration** is shorter than **D/S Max. Duration (Default: 60s)**.

Any one of channels voltage is equal to or greater than the [**Interruption (Threshold + Hysteresis) x U_{ref} .**], the interruption detection ends.

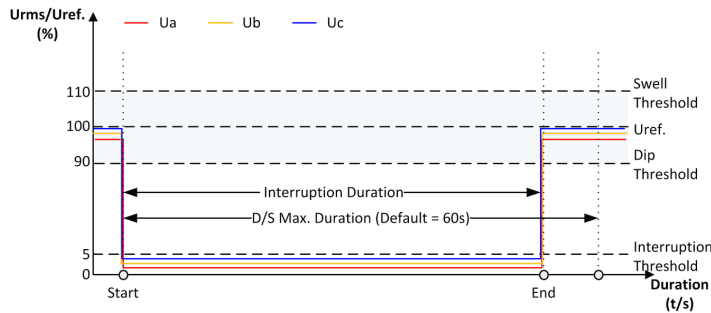

Figure 4-6 Interruption Detection Criteria

• **Undervoltage**

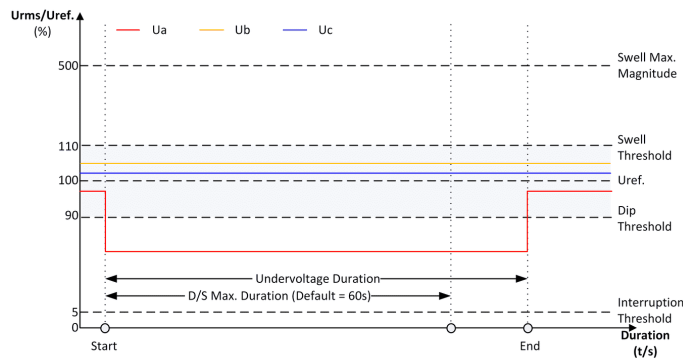

Figure 4-7 Undervoltage Detection Criteria

Undervoltage will be detected when any of the following criteria is satisfied:

1. The U_{rms} voltage of one or more channels falls below the [**Dip Threshold (Default: 90%) x U_{ref} .**].
2. **Duration** is longer than **D/S Max. Duration (Default: 60s)**.

Undervoltage will return when all 3 channels voltage exceed [**Dip (Threshold + Hysteresis) x U_{ref} .**].

4.3.5.2 PQ Disturbance Settings

The **PQ Disturbance** setup parameters can be programmed over the Front Panel, Web Interface or via Communications. The **Dip Threshold**, **Swell Threshold**, **Voltage Interruption Threshold** and **Dip/Swell Hysteresis** should be configured to meet the following criteria:

- a) The **Voltage Interruption Threshold** shall be set below the **Dip Threshold**.
- b) The **Dip/Swell Hysteresis** must be less than the **Dip/Swell Thresholds**.
- c) The **Rapid Voltage Changes (RVC) Threshold** must be less than the **Dip and Swell Thresholds**.
- d) Regardless of whether **PQ Disturbance** is enabled, the conditions for a), b) and c) must always be met.

The following table illustrates the ranges and default values for the PQ Disturbance parameters.

Parameter	Options/Range	Default
Basic		
Enable	Enable Dip/Swell/Interruption detection, 0=No, 1=Yes	1
Reference Voltage (Uref.)	Udin(Nominal Voltage), Usr ¹ (Sliding Reference Voltage)	Udin
Swell Threshold	101 to 200 (x0.01 Uref.)	110
Dip Threshold	1 to 99 (x0.01 Uref.)	90
Interruption Threshold	0 to 50 (x0.01 Uref.)	5
Swell Hysteresis	1 to 1000 (x0.001 Uref.)	20
Dip Hysteresis		
Interruption Hysteresis		
Swell Trigger Actions	See Note 2	DWR, RMSR
Dip Trigger Actions		
Interruption Trigger Actions		
Advanced		
Dip Triggers DO ³	When PQD Starts, When PQD Ends	When PQD Ends
Swell Triggers DO ³		When PQD Starts
Interrupt. Triggers DO ³		When PQD Starts
D/S RMS Update ⁴	1-cycle, ½ -cycle	1-cycle
Interruption Mode ⁵	Three Phase, Single Phase	Three Phase
D/S Max. Duration	1-600 (s)	60
Swell Max. Magnitude	101-500 (%)	500
Disturbance Direction	0=Enable, 1=Disable	0

Table 4-12 PQ Disturbance Parameters

Notes:

- 1. A Sliding Reference Voltage uses measured values filtered with a 1-minute time constant. This filter is given by

$$U_{sr(n)} = 0.9967 \times U_{sr(n-1)} + 0.0033 \times U_{(10/12)rms}$$

where

- $U_{sr(n)}$ is the present value of the **Sliding Reference Voltage**
- $U_{sr(n-1)}$ is the previous value of the **Sliding Reference Voltage**
- $U_{(10/12)rms}$ is the most recent 10/12-cycle r.m.s. value

Generally, the Sliding Reference Voltage Usr is not used in LV systems.

- 2. The following table illustrates the details of the **Swell/Dip/Interruption Trigger Action** register with a bit value of “1” meaning Active while “0” meaning Inactive.

BIT	Trigger	BIT	Trigger	BIT	Trigger
0	Alarm	17	DR #3	25	iTrigger 2
1	DO1 Closed	18	DR #4	26	iTrigger 3
2	DO2 Closed	19	DR #5	27	DWR
3	DO3 Closed	20	DR #6	28	WFR
4	DO4 Closed	21	DR #7	29	RMSR
5-14	Reserved	22	DR #8	30~31	Reserved
15	DR #1	23	Reserved		
16	DR #2	24	iTrigger 1		

Table 4-13 Swell/Dip/Interruption Trigger

3. PQD Trigger DO modes:

PQD Triggers DO	DO Close When	DO Release When
When PQD Starts	Swell Starts	<ul style="list-style-type: none"> Pulse Width = 0, DO will be released when PQD ends or PQD becomes invalid. If there is a new event that triggers the DO, the DO will remain in the Closed state and be released when all the trigger sources return. Pulse Width ≠ 0, DO will be released after the pulse width. If there is a new event that triggers the DO, the DO's pulse width will be recalculated. PQD becomes invalid if Overvoltage/Undervoltage or a Dip transitioned to Interruption is detected.
	Dip Starts	
	Interruption Starts	
When PQD Ends	Swell Ends	<ul style="list-style-type: none"> DO Pulse Width = 0, DO will be released after 1s DO Pulse Width ≠ 0, DO will be released after [PQD ends + Pulse Width]
	Dip Ends	
	Interruption Ends	

Table 4-14 PQD Trigger DO Modes

- The **D/S RMS Update** determines if the U_{rms} is computed every cycle and then shifted by ½ cycle or U_{rms} is computed every ½ cycle and then shifted by ½ cycle.
- If the **Interruption Mode** is set to **Single Phase**, the interruption detection starts when any one phase voltage U_{rms} falls below the **[Interruption Threshold x Uref.]** and ends when all three phase voltages exceed the value of **[Interruption (Threshold - Hysteresis) x Uref.]**.

4.3.5.3 Disturbance Direction Indicator

The iMeter 7A provides the Disturbance Direction Indicator as an educated guess with a confidence level for the disturbance direction of a Dip/Swell/Interruption event, whether Upstream or Downstream, and records the information in the SOE Log.

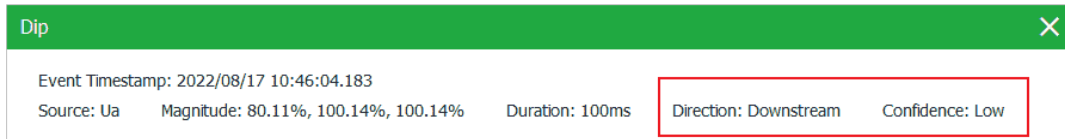

Figure 4-8 Disturbance Direction Indicator on the Web Interface

4.3.6 Transient Voltage

The iMeter 7A provides the capability for detecting Transient Voltages using the sliding-window method which compares the instantaneous value with the corresponding value on the previous cycle at a maximum resolution of 20µs (@50Hz) or 16us (@60Hz) at 1024 samples for sub-cycle disturbances such as capacitor switching and resonance phenomena, in accordance with **Section 5.6 & A.4.4 of IEC 61000-4-30 Ed. 3.1 Standard**.

The iMeter 7A provides the following setup parameters for Transient Voltages which can be programmed via the Front Panel, Web Interface and communications:

Parameter	Options/Value, Default*	Parameter	Options/Value, Default*
Enable	Yes, No*	Threshold	5% to 500% of U _{din} , 35%*
Trigger	WFR*, DWR, RMSR, iTrigger, DO		

Table 4-15 Transient Parameters

4.3.6.1 WFR of Transient Event



Figure 4-9 Transient Event @ 512 samples/cycle x 100 cycles

4.3.7 Phase Angle

Phase Angles analysis is used to identify the angle relationship between 3-phase Voltages and Currents. In the 3P4W or 3P3W system in which the phase angles between consecutive line voltages, are not all equal. The degree of the inequality is usually expressed as the ratios of the Negative- and Zero-Sequence Components to the Positive-Sequence Component, which is called Unbalance. The per-phase difference of the Current and Voltage angles should correspond to the per-phase PF. For example, if the PF is 0.5 Lag and the Voltage phase angles are 0.0°, 240.0° and 120.0°, the Current phase angles should have the values of -60.0°, 180.0° and 60.0°, respectively.

4.3.8 Supply Voltage and Current Unbalance

The iMeter 7A provides both the Zero-Sequence and Negative-Sequence Unbalance measurements for Voltage and Current, respectively, using Symmetrical Components and in accordance with Section 5.7, Section 5.13.6 of IEC 61000-4-30 Ed. 3.1 Standard for Class A performance.

$$V2 \text{ Unbalance} = \frac{V2}{V1} \times 100\% , I2 \text{ Unbalance} = \frac{I2}{I1} \times 100\% \text{ (Negative Sequence Unbalance)}$$

$$V0 \text{ Unbalance} = \frac{V0}{V1} \times 100\% , I0 \text{ Unbalance} = \frac{I0}{I1} \times 100\% \text{ (Zero Sequence Unbalance)}$$

where

V0, V1, and V2 are the Zero, Positive and Negative Sequence Components for Voltage, respectively.
and

I0, I1, and I2 are the Zero, Positive and Negative Sequence Components for Current, respectively.

4.3.9 Harmonic and Interharmonic

4.3.9.1 Voltage/Current Harmonic Measurements

The following table illustrates the Voltage and current harmonic/interharmonic measurements on the meter.

Measurements	Ua	Ub	Uc	U4	Ia	Ib	Ic	I4
THD, TOHD, TEHD, DC Components to HD63 (%)	■	■	■	■	■	■	■	■
TDD, TDD Odd, TDD Even (%)	--	--	--	--	■	■	■	■
K-Factor	--	--	--	--	■	■	■	■
Crest Factor	■	■	■	■	■	■	■	■
TH, TEH, TOH, DC Components to H63 (RMS)	■	■	■	■	■	■	■	■
TIHD, TOIHD, TEIHD, IHD00 to IHD63 (%)	■	■	■	■	■	■	■	■
TIH, TIEH, TIOH, IH00 to IH63 (RMS)	■	■	■	■	■	■	■	■

Table 4-16 Voltage and Current Harmonic/Interharmonic measurements

4.3.9.2 Harmonic Calculation Method

The basic measurement of harmonics complies with IEC 61000-4-7 Class I. The standard allows three different ways to calculate the harmonics in a 0.2s fixed data window, see Figure 4-10. On iMeter 7A, the user shall select either by a 10/12-cycle **Harmonic Group**, designated $Y_{g,h}$, or a 10/12-cycle **Subgroup**, designated $Y_{sg,h}$.

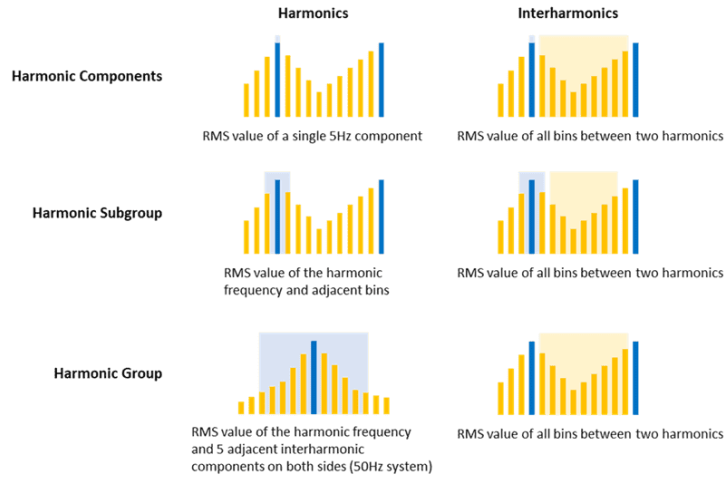

Figure 4-10 Harmonic Calculation Method

4.3.9.3 THD

For the assessment of harmonic distortion, three harmonic distortion indices are introduced in IEC 61000-4-7, named as: THD, THDS and THDG.

Total harmonic distortion (THD):

$$THD_Y = \sqrt{\sum_{h=2}^{h_{max}} \left(\frac{Y_{H,h}}{Y_{H,1}} \right)^2}$$

where

h = harmonic order (1, 2, 3, 4, ... up to 63)

$Y_{H,h}$ =RMS value of h^{th} harmonic component

Group total harmonic distortion (THDG):

$$THDG_Y = \sqrt{\sum_{h=h_{min}}^{h_{max}} \left(\frac{Y_{g,h}}{Y_{g,1}} \right)^2}$$

where

$Y_{g,h}$ =RMS value of h^{th} harmonic group

Subgroup total harmonic distortion (THDS):

$$THDGS_Y = \sqrt{\sum_{h=h_{min}}^{h_{max}} \left(\frac{Y_{sg,h}}{Y_{sg,1}} \right)^2}$$

where

$Y_{sg,h}$ =RMS value of a harmonic subgroup

On the iMeter 7A, the **THD** will be calculated using **THDG** or **THDS** depending on the harmonic calculation method (**Group** or **Subgroup**).

4.3.9.4 HD/IHD Calculation Methods

There are three methods to calculate the Harmonic/Interharmonic Distortion (HD/IHD):

a) Fundamental Method:

Voltage Kth Harmonic/Interharmonic Distortion = $\frac{U_k}{U_1} \times 100\%$ where U₁ is the Fundamental Voltage

Current Kth Harmonic/Interharmonic Distortion = $\frac{I_k}{I_1} \times 100\%$ where I₁ is the Fundamental Current

b) RMS Method:

Voltage Kth Harmonic/Interharmonic Distortion = $\frac{u_k}{\sqrt{\sum_{k=1}^{\infty} u_k^2}} \times 100\%$ where the denominator is the RMS

Current Kth Harmonic/Interharmonic Distortion = $\frac{I_k}{\sqrt{\sum_{k=1}^{\infty} I_k^2}} \times 100\%$ where the denominator is the RMS

c) Nominal Method:

Voltage Kth Harmonic/Interharmonic Distortion = $\frac{U_k}{U_{nom}} \times 100\%$ Where U_{nom} is the Nominal Voltage

Current Kth Harmonic/Interharmonic Distortion = $\frac{I_k}{I_{nom}} \times 100\%$ Where I_{nom} is the Nominal Current

4.3.9.5 Real-time TDD and IL

Total Demand Distortion (TDD) is defined as the ratio of the RMS (Root Mean Square) of the harmonic content, considering harmonic components up to **63rd** order and specifically excluding interharmonics, expressed as a percent of the **Maximum Demand Load Current (I_L)**.

TDD of Current is calculated by the formula below:

$$TDD = \frac{\sqrt{\sum_{h=1}^{h=\infty} (I_h)^2}}{I_L}$$

where

- I_L = Maximum Demand Load Current
- h = Harmonic Order (1, 2, 3, 4, etc.)
- I_h = RMS Load Current at the hth Harmonic

The **Maximum Demand Load Current (I_L)** can be predefined via **TDD Preset IL** parameter or computed automatically with the following algorithm (When **TDD Preset IL = 0**) as per IEEE Std 519-2022.

- If more than 12 month's data is available, the last 12 month's data will be used for I_L calculation by the following formula:

$$I_L = \frac{1}{12} \sum_{i=M-12}^M I_i$$

- If less than 12 month's data is available, the IL is calculated by the following formula:

$$I_L = \frac{1}{M} \sum_{i=1}^M I_i$$

Where

- M denotes the device running time in month
- I_i denotes the monthly maximum current demand for the ith month

- If less than 1 month's data is available, the meter will set IL = **This Max Current Demand**.

The **Harmonics Calculation Method**, **THD Order** and **HD Calculation**, as well as **TDD Preset IL** and **I4 TDD Preset**

IL (supported in the firmware V2.50.00 or later) can be set through the Front Panel, Web Interface, or via Communications.



Figure 4-11 PQ-Harmonics Setup Interface

4.3.9.6 Harmonic Power

The iMeter 7A provides Individual Harmonics to the 63rd order and the TH (Total Harmonic) P, Q, S and PF for 3- Φ and Total. The Total 3- Φ Harmonic Powers are only available via communications while the Individual Harmonic and TH (Total Harmonic) Powers for Phase A/B/C are available via both the Web Interface and communications.

Harmonic Power				
L1 L2 L3				
Order	P	Q	S	PF
Total	3.706 W	-0.679 var	3.767 VA	0.984
01	418.7 W	750.8 var	859.6 VA	0.487
02	-0.044 W	0.074 var	0.086 VA	-0.511
03	-3.520 W	-0.021 var	3.520 VA	-1.000
04	-0.011 W	-0.019 var	0.022 VA	-0.493
05	0.700 W	-1.184 var	1.375 VA	0.509
06	0.006 W	0.000 var	0.006 VA	1.000
07	0.329 W	0.588 var	0.674 VA	0.488
08	-0.003 W	0.005 var	0.006 VA	-0.519
09	-0.416 W	-0.008 var	0.416 VA	-1.000
10	-0.003 W	-0.005 var	0.006 VA	-0.485
11	0.145 W	-0.238 var	0.278 VA	0.519
12	0.001 W	0.001 var	0.001 VA	0.704

Figure 4-12 Harmonic Power measurement displayed on Web

4.3.9.7 Harmonic Energy

The iMeter 7A provides the Total Harmonic Energy Measurements for kWh, kvarh Import/Export and kVAh as well as the Individual Harmonic Energy Measurements to the 63rd order for kWh, kvarh Import/Export. The Harmonic Energy can be retrieved via the Front Panel, Web Interface and Communications.

Harmonic Energy				
Order	kWh Imp. (kWh)	kWh Exp. (kWh)	kvarh Imp. (kvarh)	kvarh Exp. (kvarh)
01	16,068.2	0.0	28,875.0	0.0
02	0.0	1.6	2.8	0.0
03	0.0	135.2	0.0	0.8
04	0.0	0.3	0.0	0.6
05	26.8	0.0	0.0	45.4
06	0.1	0.0	0.0	0.0
07	12.5	0.0	22.5	0.0
08	0.0	0.0	0.1	0.0
09	0.0	15.9	0.0	0.2
10	0.0	0.0	0.0	0.1
11	5.5	0.0	0.0	9.0
12	0.0	0.0	0.0	0.0
13	3.0	0.0	5.6	0.0

Figure 4-13 Harmonic Energy Displayed on the Web Server

4.3.10 K-Factor

K-factor is defined as the weighted sum of the harmonic load currents according to their effects on transformer heating, as derived from **ANSI/IEEE C57.110**. The **K-Factor** is an expression of the potential energy losses in transformers due to harmonic and eddy current losses at the fundamental frequency. A **K-Factor** of 1.0 indicates a linear load (no harmonics). The higher **K-Factor**, the greater the harmonic heating effects.

$$K-Factor = \frac{\sum_{h=1}^{h=h_{max}} (I_h h)^2}{\sum_{h=1}^{h=h_{max}} (I_h)^2}$$

I_h = h_{th} Harmonic Current in RMS

h_{max} = Highest harmonic order

4.3.11 Crest Factor

Crest Factor is defined as the **Peak to Average Ratio (PAR)** and its calculation is listed below:

$$C = \frac{|X|_{peak}}{X_{rms}}$$

$|X|_{peak}$ = Peak amplitude of the waveform

X_{rms} = RMS value

4.3.12 MSV (Mains Signalling Voltage)

Mains signalling voltage, called “ripple control signal” in certain applications, is a burst of signals, often applied at a non-harmonic frequency, that remotely control industrial equipment, revenue meters and other devices.

The iMeter 7A can monitor the Mains Signalling Voltage in a higher frequency band than system frequency (50Hz or 60Hz) in accordance with **Section 5.10 of IEC 61000-4-30 Ed. 3.1 Standard** for Class A performance.

As per 5.10 of IEC 61000-4-30 Ed. 3.1:

- ☞ *Mains Signalling Voltage is RMS voltage of mains signal.*
- ☞ *Mains signalling voltage measurement shall be based on*
 - *Either the corresponding 10/12-cycle r.m.s. value interharmonic bin*
 - *Or the r.m.s. of the four nearest 10/12-cycle r.m.s. value interharmonic bins*
- ☞ *The beginning of a signalling emission shall be detected when the measured value of the concerned interharmonic exceeds a threshold. The measured values are recorded during a period of time specified by the user, in order to give the level and the sequence of the signal voltage.*
- ☞ *The user must select a detection threshold above 0.3% U_{din} as well as the length of the recording period up to 120s.*

The iMeter 7A provides the following setup parameters which can be programmed via the Front Panel, Web Interface and communications:

Parameter	Options/Value, Default*	Parameter	Options/Value, Default*
Enable	Yes, No*	Frequency	60 to 3k Hz, 1k(MSV1)*, 2k(MSV2)*, 3k(MSV3)*
Threshold	0.3% to 100% of U_{din} , 5%*	Signalling Time	1 to 120s, 60s*

Table 4-17 MSV Parameters

The iMeter 7A can simultaneously detect three different frequencies for Mains Signalling Voltage. The emission signalling will trigger SOE, recording the Trigger Source and Max. Volt. of three-phase voltages.

4.3.13 RVC (Rapid Voltage Change)

The iMeter 7A provides the ability to capture RVC in accordance with **Section 5.11 & A.5 of the IEC 61000-4-30 Ed. 3.1 Standard** for Class A performance.

As per 5.11 of IEC 61000-4-30 Ed. 3.1:

- ☞ *A rapid voltage change is a quick transition in RMS voltage occurring between two steady-state conditions and during which the RMS voltage does not exceed the dip/swell thresholds.*

- ☞ An RMS voltage is in a steady-state condition if all the immediately preceding 100/120 $U_{rms(1/2)}$ values remain within an RVC threshold from the arithmetic mean of those 100/120 $U_{rms(1/2)}$ values.
- ☞ The RVC threshold and hysteresis are set by the user according to the application, as percentage of U_{din} and the hysteresis should be less than the threshold.

4.3.13.1 Rapid Voltage Change Evaluation

A Rapid Voltage Change event is characterized by 4 parameters: **Start time**, **Duration**, ΔU_{max} and ΔU_{ss} .

- **Start Time** When the “Voltage-is-Steady-State” logic signal becomes False and initiates the RVC event.
- **Duration** 100/120 half-cycle prior to the “Voltage-is-Steady-State” logic signal returns to True from False.
- ΔU_{max} The absolute maximum difference between any of the $U_{rms(1/2)}$ values during the RVC event and the final arithmetic mean 100/120 $U_{rms(1/2)}$ value just prior to the RVC event.
- ΔU_{ss} The absolute difference between the final arithmetic mean 100/120 $U_{rms(1/2)}$ value just prior to the RVC event and the first arithmetic mean 100/120 $U_{rms(1/2)}$ value after the RVC event.

The iMeter 7A provides the following setup parameters which can be programmed via the Front Panel, Web Interface or communications:

Parameter	Options/Value, Default*	Parameter	Options/Value, Default*
Enable	Yes, No*	Threshold	0.2% to 10% of U_{din} , 5%*
Hysteresis	0.1 to 5 (%) of U_{din} , 2.5%*	Trigger	WFR, DWR, RMSR*, DO, iTrigger

Table 4-18 RVC Parameters

4.3.13.2 RMSR for an RVC Event

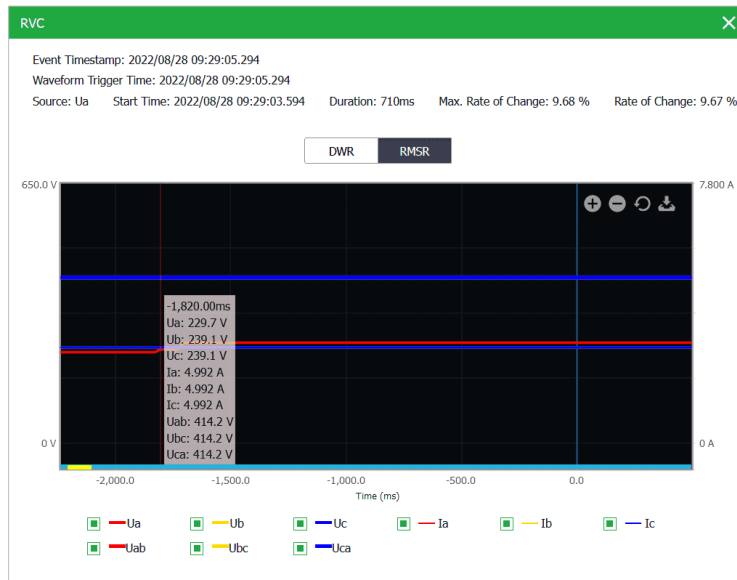

Figure 4-14 RMSR for an RVC Event

4.3.14 Underdeviation and Overdeviation

The iMeter 7A provides the ability to capture the **Voltage Deviation** in accordance with the **IEC 61000-4-30 Ed. 3.1 Standard**.

As per Section 5.12 and Annex D (Informative) of IEC 61000-4-30 Ed. 3.1

- ☞ The 10/12-cycle *r.m.s* value, $U_{rms(10/12), i}$ should be used to assess the underdeviation and overdeviation parameters in percent of U_{din} . The underdeviation $U_{rms-under}$ and overdeviation $U_{rms-over}$ parameters are determined by the following equations:

Calculation of $U_{rms-under, i}$:

If $U_{rms(10/12), i} > U_{din}$ then $U_{rms-under, i} = U_{din}$

If $U_{rms(10/12), i} \leq U_{din}$ then $U_{rms-under, i} = U_{rms(10/12), i}$

Calculation of $U_{rms-over, i}$:

If $U_{rms(10/12),i} < U_{din}$ then $U_{rms-over,i} = U_{din}$
 If $U_{rms(10/12),i} \geq U_{din}$ then $U_{rms-over,i} = U_{rms(10/12),i}$

And the Underdeviation/Overdeviation should be calculated based on the following:

Underdeviation:

$$U_{under} = \frac{U_{din} - \sqrt{\frac{\sum_{i=1}^n U_{rms-under,i}^2}{n}}}{U_{din}}$$

Overdeviation:

$$U_{over} = \frac{\sqrt{\frac{\sum_{i=1}^n U_{rms-over,i}^2}{n}} - U_{din}}{U_{din}}$$

Where

n = the number of 10/12 cycle RMS values for under or overdeviation

and

$U_{rms-under,i} / U_{rms-over,i}$ is the i^{th} 10/12-cycle RMS value.

The iMeter 7A is capable of measuring Voltage Deviations with an accuracy of 0.1% and monitoring Voltage Deviation online. In addition, the Voltage Deviation is supported by the Setpoint function. Please refer to **Chapter 3 User Interface** for the Deviation parameters on the Front Panel and Web Interface.

4.3.15 Flagging Concept

The iMeter 7A supports the Flagging Concept as per **Section 4.7 of IEC 61000-4-30 Ed. 3.1 Standard**:

- ☞ *During a dip, swell, or interruption, the measurement algorithm for other parameters (for example, frequency measurement) might produce an unreliable value. The flagging concept therefore avoids counting single event more than once in different parameters (for example, counting a single dip as both a dip and a frequency variation) and indicates that an aggregated value might be unreliable.*
- ☞ *Flagging is only triggered by dips, swells and interruptions*. The detection of dips and swells is dependent on the threshold selected by the user and this selection will influence which data are "flagged".*
- ☞ *The flagging concept is applicable for Class A measurement performance during measurement of power frequency, voltage magnitude, flicker, supply voltage unbalance, voltage harmonics, voltage interharmonics, mains signalling and measurement of underdeviation and overdeviation parameters.*
- ☞ *If during a given time interval any value is flagged, the aggregate value indicating that value shall also be flagged. The flagged value shall be stored and also included in the aggregation process, for example, if during a given time interval any value is flagged the aggregated value that includes this value shall also be flagged and stored.*

*Besides, flagging will be triggered by the detection of $I > 2In$ on iMeter 7A.

In Flagging Status registers for real-time Voltage, Frequency, Pst and Plt, as well as Pst and Plt Log, a bit value of "1" indicates that a particular group of data has been flagged due to Dip (BIT0), Swell (BIT1), or Interruption (BIT2). And in Flagging Status register for real-time Current measurements, a value of "1" indicates that a particular group of data has been flagged due to overcurrent.

For SDR Log, Max. Log, Min. Log, IEEE Std 519 and/or EN 50160 Log, if the corresponding Flagged Data Setup is set to **Remove**, its log entry will be discarded and will not be included in the statistical evaluation if any data within the log entry has been flagged. And in the Flagging Status registers, a value of "0" indicates no flagged data, and "1" indicates that a particular group of data has been flagged and removed while "2" indicates the flagged data has been kept.

4.3.16 Conducted Emissions in the 2kHz to 150kHz range

The iMeter 7A is capable of providing an overview of conducted emissions in the supraharmois 2kHz-150kHz range in a power quality context, compliant with **Annex C (Informative) of IEC 61000-4-30 Ed. 3.1 Standard**.

- ☞ *These emissions are presumed to be quasi-steady-state levels, although they may have amplitude modulation.*
- ☞ *Useful Information about measurement in the 2 kHz to 150 kHz range can be found in IEC 61000-4-7: 2002, Annex B (2 kHz to 9 kHz), and CISPR 16 (9 kHz to 150 kHz).*

4.3.16.1 Measurement Method – 2kHz to 9kHz

As per IEC 61000-4-7: 2002 Annex B

- ☞ *The measurement of these components (2kHz to 9kHz) does not require a high resolution in the frequency domain. Instead, it is customary to group the energy of the signal to be analyzed into predefined frequency bands, the bandwidth for the grouping of these emissions should be fixed at 200Hz. The center frequency of the first possible group is 2.1kHz.*
- ☞ *For the frequency analysis, the DFT method and for the grouping procedure a method similar to that described in 5.5.1, are under consideration. The DFT method is suitable for voltage and current measurements whereas CISPR 16 considers only voltages.*

4.3.16.2 Measurement Method – 9kHz to 150kHz

As per IEC 61000-4-30 Ed. 3.1 Annex C

- ☞ *The frequency range of 9kHz to 150kHz could be divided into equal-width segments. The segment width could be an integer multiple of 200Hz, preferably either 200Hz or 2kHz). For the purpose of this measurement method, it is acceptable to process a frequency range beyond 9kHz to 150kHz, for example processing the range 8kHz to 150kHz if a 2kHz segment width is selected.*
- ☞ *The minimum, average, and maximum magnitude of the RMS voltage in each frequency segment in the 9kHz to 150kHz range could be recorded during each 10/12-cycle interval. In addition, the single maximum value in any segment, on any channel, could be recorded.*

4.3.16.3 Real-Time RMS Data

The iMeter 7A provides the real-time 3- Φ U_{rms} and I_{rms} for 2kHz to 9kHz which is divided into 35 equal-width segments.

- Frequency band resolution – 200Hz bins
- Aggregation interval – 3s

And for the 9kHz to 150kHz frequency range which is divided into 71 equal-width segments, the iMeter 7A also provides the real-time 3- Φ average U_{rms} .

- Frequency band resolution – 2kHz bins
- Aggregation interval – 3s

All the real-time measurements are retrievable via the Front Panel, Web Interface or through Communications.

4.3.16.4 Daily Heat Map

The iMeter 7A continually records the Max. / Min. / Avg. / CP95 values of Conducted Emissions in each frequency segment in 1-min intervals. It also records the peak values of Max. / Min. / Avg. / CP95 in a day and their located frequency segment with the timestamp.

As shown in the following figure, the horizontal axis of the graph represents the hours in one day. The vertical axis of the graph represents the emission frequency spectrum for Ia from 2kHz to 9kHz. The color map shows the peak amplitude in 1-min interval and at a given frequency. It is expressed in Amps. The table at the bottom displays the peak value of Ia Max. in the 2kHz to 9kHz range, the related frequency segment and the time of occurrence.

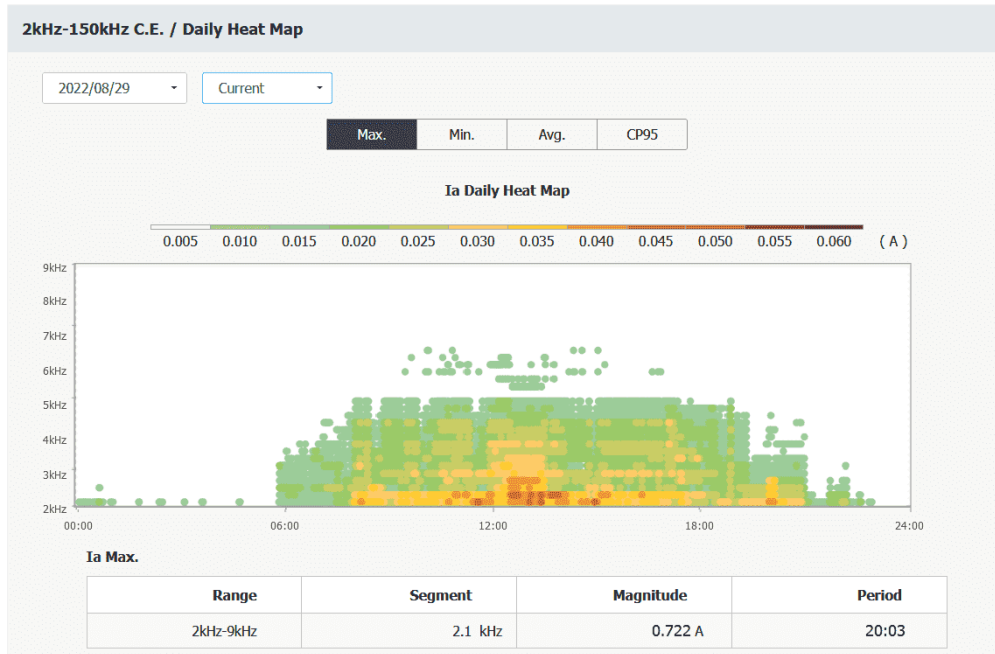

Figure 4-15 Daily Heat Map for Ia Max.

The iMeter 7A can store up to 30 daily records based on a First-in-First-out principle. All the records can be downloaded from the Web or FTPS Servers. The historical daily records can be reset via Web Server or Communications.

4.3.17 Inrush Current

Inrush current refers to the maximum instantaneous current drawn by a power supply or electrical device at turn-on, often several times their normal full-load current, when first energized such as the turning on of an AC electric motor or the energization of a transformer or a capacitor bank. The higher-than-normal inrush current typically only lasts for a few cycles before returning to its steady-state condition.

As per **Section A6.4 of IEC61000-4-30 Ed.2 Standard**, the iMeter 7A supports the detection of Inrush Current as a supplement to voltage measurements, especially when trying to determine the causes of events such as voltage dip.

☞ *The inrush current begins when the $I_{half_cyc_rms}$ current rises above the **Inrush Threshold** and ends when the $I_{half_cycle-rms}$ current is equal to or below the **Inrush Threshold** minus a user-selected **Inrush Hysteresis** value.*

☞ *The inrush current can be further characterized by*

- *the time duration between the beginning and the end of the inrush current*
- *the maximum value of the measurement inrush current $I_{half_cyc_rms}$*
- *the square root of the mean of the squared $I_{half_cyc_rms}$ values measured during the inrush duration*

The $I_{half_cyc_rms}$ is calculated by the following equation:

$$I_{half_cyc_rms} = \sqrt{\frac{1}{T/2} \int_0^{T/2} i^2(t) dt}$$



Figure 4-16 Inrush Current - displayed on Web Server

The following table illustrates the ranges and default values for the Inrush Current parameters:

Parameter	Options/Value, Default*	Parameter	Options/Value, Default*
Enable	Yes, No*	Threshold	100% to 500% of In, 120%*
Hysteresis	0.1% to 100% of In, 1%*	Trigger	WFR*, DWR, RMSR, DO, DR, iTrigger

Table 4-19 Inrush Current Parameters

4.3.18 EN 50160 Compliance Report

The EN 50160 Standard defines the **Voltage Characteristics of Electricity Supplied by Public Distribution Systems**. It provides the limits within which any customer can expect voltage characteristics to remain. For a complete definition of the non-conformity level for each of the following EN 50160 parameters, please consult the EN 50160 Standard document.

The iMeter 7A can measure, summarize data and statistically relevant data in accordance with the EN 50160 standard. Further, the device will create a report per week based on the following measurements and store the report for one year.

- Power Frequency, including Maximum and Minimum
- Supply Voltage Variations, including Maximum and Minimum
- Flickers, including Max./Min. and CP95
- Voltage Unbalance, including Max./Min. and CP95
- Harmonic and Interharmonic Voltage, including Max./Min., Average and CP95
- Mains Signalling Voltage, including Max./Min. and CP95
- Rapid Voltage Changes
- Dips and Swells with statistical parameters classified according to characteristic voltage and duration
- Interruptions with statistical parameters classified according to the duration
- Transient

The following table illustrates the default limits for the EN 50160 parameters.

EN 50160 Parameter	Setting Level	Voltage			
		Low	Medium	High	Extra-High~
Power Frequency	Wide Tolerance (%)	100	100	100	100
	Wide Tolerance Limit (%)	94 ~ 104	94 ~ 104	94 ~ 104	94 ~ 104
	Narrow Tolerance (%)	99.5	99.5	99.5	99.5
	Narrow Tolerance Limit (%)	99 ~101	99 ~101	99 ~101	99 ~101
Supply Voltage Variations	Wide Tolerance (%)	100	100	100	100
	Wide Tolerance Limit (%)	85 ~ 110	85 ~ 115	85 ~ 115	85 ~ 115
	Narrow Tolerance (%)	95	99	99	99
	Narrow Tolerance Limit (%)	90 ~ 110	90 ~ 110	90 ~ 110	90 ~ 110
Flicker Severity	Tolerance (%)	95	95	95	95
	Limit	1	1	1	1
Supply Voltage Unbalance	Tolerance (%)	95	95	95	95
	Limit (%)	2	2	2	2
Voltage Harmonic Limits	Tolerance (%)	95	95	95	95
	Total (%)	8	8	8	8
	H02 (%)	2	2	1.9	1.9
	H03 (%)	5	5	3	3
	H04 (%)	1	1	1	1
	H05 (%)	6	6	5	5
	H07 (%)	5	5	4	4
	H09 (%)	1.5	1.5	1.3	1.3
	H11 (%)	3.5	3.5	3	3
	H13 (%)	3	3	2.5	2.5
	H15 (%)	1	0.5	0.5	0.5
	H17 (%)	2	2	100	100
	H19/H23/H25 (%)	1.5	1.5	100	100
	H21 (%)	0.75	0.5	0.5	0.5
H06/H08/H10/H12/H14/ H16/H18/H20/H22/H24 (%)	0.5	0.5	0.5	0.5	

~Available in Firmware V2.50.08 or later.

Table 4-20 Default Values for EN 50160 Settings

The programming of the EN 50160 reporting is supported via the Web interface and communications. The EN 50160 Report can be accessed through the Front Panel, Web Interface or via communications. The iMeter 7A can store up to 52 weekly reports. If there are more than 52 reports, the newest report will replace the oldest on a FIFO basis. Please refer to **Section 3.2.3.3.7** for an EN 50160 sample report from the Web Interface.

4.3.19 ITIC/SEMI F47 Plot and Alarm

ITIC curve provides an AC voltage boundary that most information technology equipment (ITE) can tolerate or ride through without experiencing unexpected shutdowns or malfunctions.

No Interruption in Function (Region A): Equipment is expected to operate properly.

No Damage (Region B): Voltage dips, dropouts, and steady-state voltages in this region are not expected to damage the ITE. It is possible to cause the load to drop out due to a lack of energy.

Prohibited (Region C): Any surges or swells in this region could result in damage to the ITE.

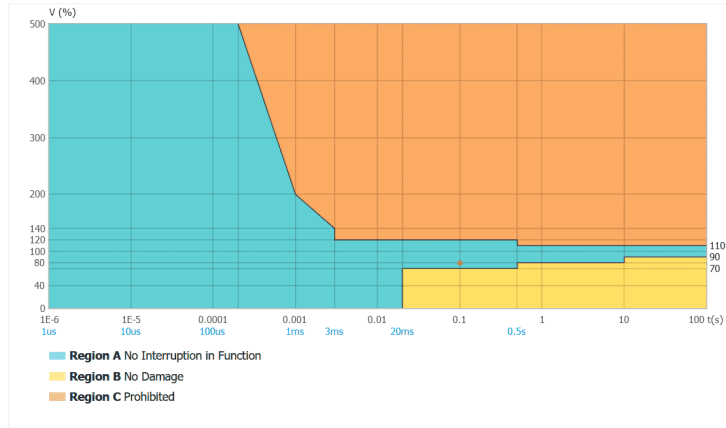

Figure 4-17 ITIC Plot Descriptions

SEMI F47 sets out limits of voltage Dip that the equipment needs to tolerate without creating any process upsets or shutdowns.

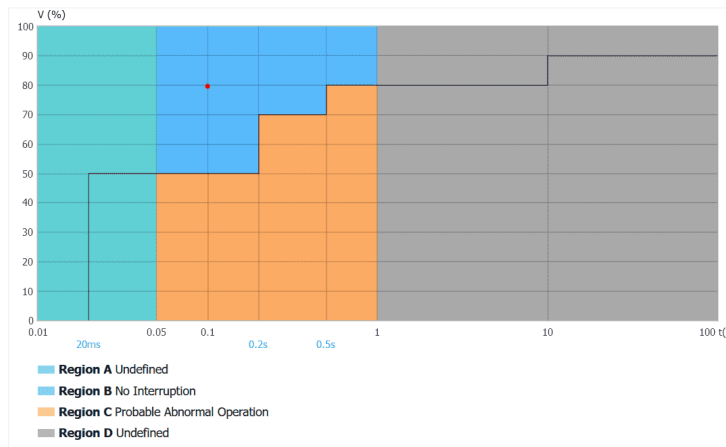

Figure 4-18 SEMI F47 Plot Descriptions

ITIC & SEMI F47 Curve and Alarm

The iMeter 7A’s Front Panel and Web Page can display the ITIC plot for Dip, Swell and Interruption events but only the SEMI F47 plot for Dip and Interruption events. In addition, ITIC/SEMI F47 Alarm will trigger DO/iTrigger upon the detection of PQ disturbances that are outside of the respective tolerance curves:

- ☞ ITIC Alarm: When the voltage is in the **No Damage Region B** or **Prohibited Region C** which means the voltage exceeds Dip/Swell or Interruption limits and the latest voltage exceeds the tolerated limit, the DO/iTrigger would be triggered.
- ☞ SEMI F47 Alarm: When the voltage exceeds the Dip limits and the latest voltage exceeds the tolerated limit, the DO/iTrigger would be triggered.

The following table lists the setup parameters for the ITIC/SEMI F47 alarm:

Parameter	Definition	Default
ITIC/SEMI F47 Alarm Trigger	DOs and iTriggers If Pulse Width = 0, the DO will be released after 1s. If Pulse Width ≠ 0, the DO will be released after the configured Pulse width. If the DO is closed when the SEMI F47 Alarm becomes active, the DO keeps the Closed state.	N/A

Figure 4-19 Definitions for ITIC/SEMI F47 Alarm Trigger

4.3.20 IEEE Std 519-2022 Compliance Report

The IEEE 519 standard describes the voltage and current harmonic distortion measurements, analysis methods and practice limits for harmonics control applied at the point of common coupling (PCC). The iMeter 7A provides a solution that generates IEEE 519-2022 compliance Daily and Weekly reports with easy configurations.

The IEEE 519-2022 standard defines four sets of limits for the individual voltage harmonics up to 50th and Total Harmonic Distortion (THD), depending on the PCC voltage level. And it also defines the limits of individual current harmonics divided into 5 groups (2nd - 10th, 11th - 16th, 17th - 22nd, 23rd - 34th and 35th - 50th) as well as Total Demand Distortion (TDD).

4.3.20.1 Terms Definition

The definition of the following terms applied to this section are described below. The [IEEE Standards Dictionary Online](#) should be consulted for other terms not mentioned below.

Point of Common Coupling (PCC) – Point on a public power supply system, electrically nearest to a particular load, at which other loads are, or could be, connected. The PCC is a point located upstream of the considered installation.

Maximum Demand Load Current (I_L) – This current value is enacted at the PCC and calculated as the average of the currents corresponding to the peak demand during the previous 12 months.

Short Circuit Ratio (SCR) – At a particular location, the ratio of the available short circuit current, in amperes, to the maximum demand load current, in amperes.

4.3.20.2 Harmonics Evaluation

The IEEE 519-2022 standard requires the harmonic data to the 50th on aggregation of 150/180 cycles (3s) and 10min for the statistical assessments. As per IEEE 519-2022, the Voltage Harmonic compliance criteria are:

- Daily 99th percentile 3s values should be less than 1.5 times the values given in the table below.
- Weekly 95th percentile 10-min values should be less than the values given in the table below.

Bus Voltage V at PCC	Individual Harmonic (%)	THD (%)
$V \leq 1.0$ kV	5.0	8.0
1 kV < $V \leq 69$ kV	3.0	5.0
69 kV < $V \leq 161$ kV	1.5	2.5
161 kV < V	1.0	1.5*

Table 4-21 Voltage Harmonic Compliance Limit

*High-voltage systems are allowed to have up to 2% THD where the cause is an HVDC terminal whose effects are found to be attenuated at points in the network where future users may be connected.

And the Current Harmonic compliance criteria are:

- Daily 99th percentile 3s values should be less than 2.0 times the values given in the table below.
- Weekly 99th percentile 10-min values should be less than 1.5 times the values given in the table below.
- Weekly 95th percentile 10-min values should be less than the values given in the table below.

120V - 69kV system						
I_{sc}/I_L	$2 \leq h < 11^*$	$11 \leq h < 17$	$17 \leq h < 23$	$23 \leq h < 35$	$35 \leq h \leq 50$	TDD
< 20**	4.0	2.0	1.5	0.6	0.3	5.0
20 < 50	7.0	3.5	2.5	1.0	0.5	8.0
50 < 100	10.0	4.5	4.0	1.5	0.7	12.0
100 < 1000	12.0	5.5	5.0	2.0	1.0	15.0
> 1000	15.0	7.0	6.0	2.5	1.4	20.0
69kV - 161kV system						
I_{sc}/I_L	$2 \leq h < 11^*$	$11 \leq h < 17$	$17 \leq h < 23$	$23 \leq h < 35$	$35 \leq h \leq 50$	TDD
< 20**	2.0	1.0	0.75	0.3	0.15	2.5
20 < 50	3.5	1.75	1.25	0.5	0.25	4.0
50 < 100	5.0	2.25	2.0	0.75	0.35	6.0
100 < 1000	6.0	2.75	2.5	1.0	0.5	7.5
> 1000	7.5	3.5	3.0	1.25	0.7	10.0
Above 161kV system						
I_{sc}/I_L	$2 \leq h < 11^*$	$11 \leq h < 17$	$17 \leq h < 23$	$23 \leq h < 35$	$35 \leq h \leq 50$	TDD
< 25**	1.0	0.5	0.38	0.15	0.1	1.5
25 < 50	2.0	1.0	0.75	0.3	0.15	2.5
≥ 50	3.0	1.5	1.15	0.45	0.22	3.75

Table 4-22 Current Harmonic Compliance Limit

* For $h \leq 6$, even harmonics are limited to 50% of the Harmonic limits shown in the table.

** Power generation facilities are limited to these values of current distortion, regardless of actual I_{sc}/I_L unless covered by other standards with applicable scope.

Where

I_{sc} = Maximum short-circuit current at PCC

I_L = Maximum demand load current at PCC under normal load operating conditions.

h = Individual harmonic order

4.3.20.3 Configuration

To generate the IEEE Std 519 Daily/Weekly reports, the iMeter 7A automatically switches to the applicable voltage and current harmonic limits according to the IEEE 519-2022 standard based on the following configuration.

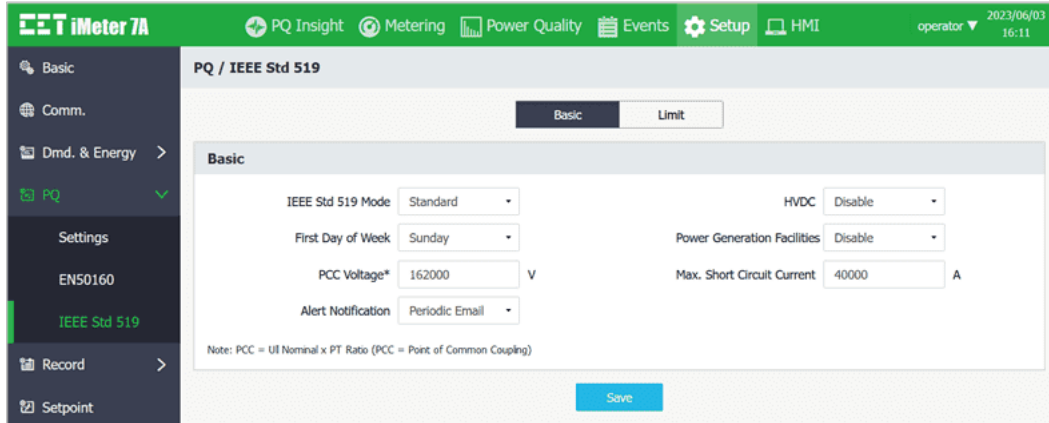

Figure 4-20 IEEE Std 519 Basic Parameters Configuration via Web Interface

The following table illustrates the setting range and default values for these parameters.

Parameter	Options/Range, Default*	Comment
IEEE Std 519 Mode	Disable* / Standard / Custom	Standard – Use measured IL ¹ for SCR calculation and determining the limits according to IEEE Std 519-2022 for report generation. Custom – Use custom TDD Preset IL² (see Section 4.3.9.5) for SCR calculation. User may customize the harmonic limits for report generation.
HVDC	Enable / Disable*	High-voltage systems (> 161kV) are allowed to have a higher voltage THD where the cause is an HVDC terminal. In this condition, enable the HVDC parameter to increase the voltage THD tolerance to 2% (see Table 4-21).
First Day of Week	Sunday* to Monday	--
Power Generation Facilities	Disable* / Enable	For power generation equipment, enable this parameter to limit the current distortion to those value in row for < 20 or < 25 group in Table 4-22, regardless of actual Isc/IL.
PCC Voltage	1 to 9,999,000 (V), 415*	PCC Voltage = UII Nominal x PT Ratio.
Max. Short Circuit Current	1 to 9,999,000 (A), 40000*	This is the maximum short circuit current could be produced at PCC according to the PCC voltage and the supply impedance at PCC, rather than the maximum MCCB rating.
Alert Notification	Alarm Email*, Periodic Email	Alarm Email – Send an email when the report is generated. Periodic Email – Send an email if an evaluation result in the report is fail.

Table 4-23 IEEE Std 519 Report Parameters Configuration

Notes:

- In **Standard** mode, for a new installation, the monthly maximum current demand is not available.
 - If Preset IL ≠ 0: the meter will use Preset IL for SCR calculation and determining the current harmonic distortion limits in the first month (M < 1),
 - If Preset IL = 0: the meter will use the greater of **This Max. Current Demand** and **I Nominal*CT Ratio** for SCR cal. and for determining the current harmonic distortion limits in the first month (M < 1).
- It is necessary to reboot the device to allow the new changes to **Preset IL** to take effect. The harmonic current distortion limits will be updated accordingly after reboot.
- Modification of the **Max. Short Circuit Current** (Isc) may change the SCR (Isc/IL) ratio and result in a change in the harmonic current distortion limits.
- Before a new round commissioning test after installation, it is recommended to perform the **Clear All Demands** and **Reset IL** to clear the historical demand and IL record for generating a report for verification purpose.

4.3.20.4 Report Generation

The iMeter 7A generates the IEEE Std 519 Daily Report and the Weekly Report on the basis of the 3-second interval data measured in one day and the 10-min interval data measured in one week, respectively. Each of the daily/weekly reports consists of a voltage compliance report and a current compliance report. The iMeter 7A can store up to 356 daily reports and 52 weekly reports on a first-in-first-out basis.

4.3.20.4.1 Daily Report Displayed on Web Server

- Voltage Harmonic Compliance Report**

As shown in the following figure, the IEEE Std 519 Daily Voltage Harmonic Compliance Report begins with the **Voltage Level**, then the **99th percentile** values for **THD** and **Individual Harmonics** from 2nd to 7th, along with the IEEE Std 519 specified limits and a pass/fail conclusion where **✓** denotes the positive evaluation while **✗** denotes the negative evaluation.

Order (h)	CP99 (%)			Limit (%)	Conclusion
	Ua	Ub	Uc		
THD	9.13	9.13	9.13	12.000	✓
TOHD	9.05	9.05	9.05	--	--
TEHD	1.21	1.21	1.21	--	--
Individual Harmonics					
H02	1.00	1.00	1.00	7.500	✓
H03	6.40	6.40	6.40	7.500	✓
H04	0.50	0.50	0.50	7.500	✓
H05	4.00	4.00	4.00	7.500	✓
H06	0.26	0.26	0.26	7.500	✓
H07	2.80	2.80	2.80	7.500	✓

Figure 4-21 IEEE Std 519 Daily Voltage Harmonics Compliance Report

- Current Harmonic Compliance Report**

As shown in the following figure, the IEEE Std 519 Daily Current Harmonic Compliance Report begins with the **Voltage Level**, **Isc**, **IL** and **Isc/IL** then the **99th percentile** values for the **TDD**, and **Individual Harmonics** from 2nd to 7th, along with the IEEE Std 519 specified limits and a pass/fail conclusion where **✓** denotes the positive evaluation while **✗** denotes the negative evaluation.

Order (h)	CP99 (%)			Limit (%)	Conclusion
	Ia	Ib	Ic		
TDD	0.11	0.11	0.11	10.000	✓
TDD Odd	0.11	0.11	0.11	--	--
TDD Even	0.02	0.02	0.02	--	--
Individual Harmonics					
H02	0.01	0.01	0.01	4.000	✓
H03	0.08	0.08	0.08	8.000	✓
H04	0.01	0.01	0.01	4.000	✓
H05	0.05	0.05	0.05	8.000	✓
H06	0.00	0.00	0.00	4.000	✓
H07	0.04	0.04	0.04	8.000	✓

Figure 4-22 IEEE Std 519 Daily Current Harmonics Compliance Report

4.3.20.4.2 Weekly Report Displayed on Web Server

• Voltage Harmonic Compliance Report

Similar to the Daily Report, the Weekly Voltage Harmonic Compliance Report provides the **Voltage Level**, the **95th** percentile values for **THD** and **Individual Harmonics** from 2nd to 7th, along with the IEEE Std 519 specified limits and a pass/fail conclusion.

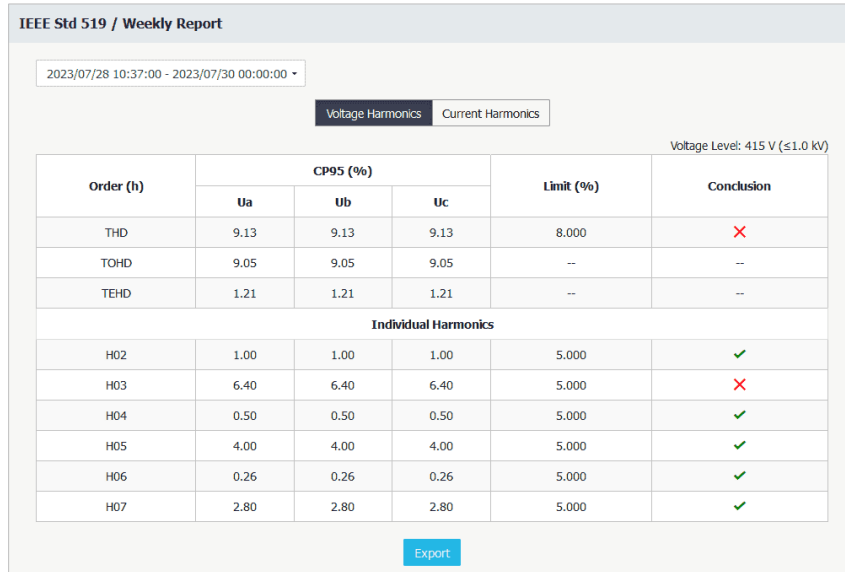

Order (h)	CP95 (%)			Limit (%)	Conclusion
	Ua	Ub	Uc		
THD	9.13	9.13	9.13	8.000	✗
TOHD	9.05	9.05	9.05	--	--
TEHD	1.21	1.21	1.21	--	--
Individual Harmonics					
H02	1.00	1.00	1.00	5.000	✓
H03	6.40	6.40	6.40	5.000	✗
H04	0.50	0.50	0.50	5.000	✓
H05	4.00	4.00	4.00	5.000	✓
H06	0.26	0.26	0.26	5.000	✓
H07	2.80	2.80	2.80	5.000	✓

Figure 4-23 IEEE Std 519 Weekly Voltage Harmonics Compliance Report

• Current Harmonic Compliance Report

The IEEE Std 519 Weekly Current Harmonic Compliance Report provides the **Voltage Level**, **Isc**, **IL**, and **Isc/IL**, then the **95th** and **99th** percentile values for the **TDD**, and **Individual Harmonics** from 2nd to 7th, along with the IEEE Std 519 specified limits and a pass/fail conclusion.

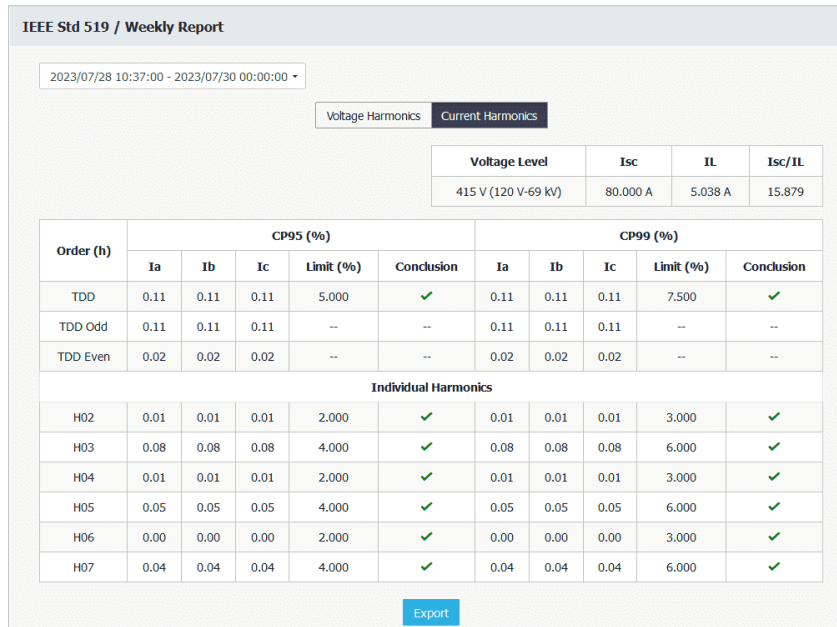

Order (h)	CP95 (%)					CP99 (%)				
	Ia	Ib	Ic	Limit (%)	Conclusion	Ia	Ib	Ic	Limit (%)	Conclusion
TDD	0.11	0.11	0.11	5.000	✓	0.11	0.11	0.11	7.500	✓
TDD Odd	0.11	0.11	0.11	--	--	0.11	0.11	0.11	--	--
TDD Even	0.02	0.02	0.02	--	--	0.02	0.02	0.02	--	--
Individual Harmonics										
H02	0.01	0.01	0.01	2.000	✓	0.01	0.01	0.01	3.000	✓
H03	0.08	0.08	0.08	4.000	✓	0.08	0.08	0.08	6.000	✓
H04	0.01	0.01	0.01	2.000	✓	0.01	0.01	0.01	3.000	✓
H05	0.05	0.05	0.05	4.000	✓	0.05	0.05	0.05	6.000	✓
H06	0.00	0.00	0.00	2.000	✓	0.00	0.00	0.00	3.000	✓
H07	0.04	0.04	0.04	4.000	✓	0.04	0.04	0.04	6.000	✓

Figure 4-24 IEEE Std 519 Weekly Current Harmonics Compliance Report

The entire IEEE Std 519 Daily/Weekly Compliance Report provided by iMeter 7A includes the **Min.**, **Max.**, **Avg.** and percentile values for voltage **THD** and **Individual Harmonics** from 2nd to 50th, as well as current **TDD** and **Individual Harmonics** from 2nd to 50th. The user may obtain the entire report for a given date by exporting it from the Web/FTP server or by communication or receive it by e-mail via the SMTPS service as soon as it is generated or if the evaluation result of any item in the report is fail.

4.4 Motor Start Monitoring

4.4.1 Motor State

The iMeter 7A considers 4 conditions for the monitored motor, Start, Running, Stop and Non-supervision.

4.4.1.1 Start State

The initial state of a motor is stop. The iMeter 7A considers a motor starting from stop based on any of the following criteria:

- 1) The maximum value of 3-phase RMS current, I_{max} , exceeds motor starting current threshold ($1.2I_e$)
- 2) The I_{max} exceeds $0.004I_n$ (I_n stands for nominal current of iMeter 7A) with a specified delay of 0.1s.

4.4.1.2 Running State

The meter considers a motor transition to running state based on the detection of the I_{max} falls below $1.2I_e$ but still exceeds $0.02I_n$ for at least 60ms.

4.4.1.3 Non-supervision State

When the meter is restarting or the Motor Start Monitoring is disabled, the iMeter 7A considers the motor as non-supervised.

4.4.1.4 Stop State

The iMeter 7A considers a motor stop based on the detection of I_{max} falling below $0.02I_n$ with a specified delay of 0.1s.

4.4.2 Motor Start Monitoring

The iMeter 7A can monitor the **Motor Startup** procedure with the recording of the characteristic information such as I_{max} , U_{min} and Duration in the SOE Log as well as triggering DO, DR, WFR, DWR, iTrigger and RMSR.

I_{max} – Maximum start current

U_{min} – Minimum start voltage

Duration – Time differences between the motor start detection and motor running/stop state detection.

The following table illustrates the ranges and default values for **Motor Start Monitoring** parameters.

Parameter	Options/Range, Default*	Parameter	Options/Range, Default*
Enable	Yes, No*	Motor Inom. Sec. (Ie)	0.01 - 6.00A, 5.00A*
Trigger	DO, iTrigger, DWR*, WFR, RMSR*		

Table 4-24 Motor Start Monitoring Parameters

4.5 Setpoint

The iMeter 7A comes with 64 programmable Setpoints which allow users to initiate an action in response to a specific condition. Typical setpoint applications include alarming, control and power quality monitoring.

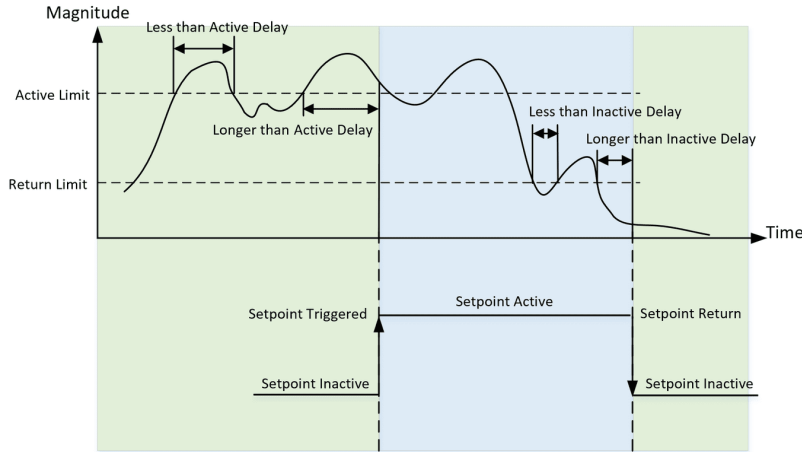

Figure 4-25 Over Setpoint

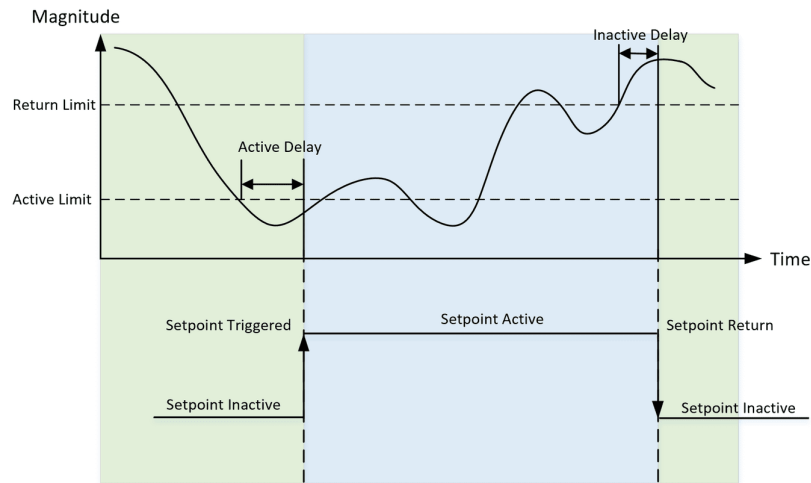

Figure 4-26 Under Setpoint

The Setpoints can be programmed via the Web Interface or communications and have the following setup parameters:

Parameters	Definition	Options/Default*
Type	Disabled, Over or Under Setpoint.	0=Disabled* 1=Over, 2=Under
Parameter	Specify the parameter to be monitored.	See Table 4-26
Active Limit	Specify the value that the setpoint parameter must exceed for Over Setpoint or go below for Under Setpoint for the setpoint to become active.	-2147483647 to 2147483647, Null*
Return Limit	Specify the value that the setpoint parameter must go below for Over Setpoint or exceed for Under Setpoint for the setpoint to become inactive.	-2147483647 to 2147483647, Null*
Active Delay	Specify the minimum duration that the setpoint condition must be met before the setpoint becomes active. An event will be generated and stored in the SOE Log.	0 to 9999.99 (s), 10*
Inactive Delay	Specify the minimum duration that the setpoint return condition must be met before the setpoint becomes inactive. An event will be generated and stored in the SOE Log.	0 to 9999.99 (s), 10*
Trigger	Specify what action a setpoint can take when it becomes active.	None*, DR, DO, DWR, WFR, RMSR, iTrigger

Table 4-25 Description of Setpoint Parameters

The iMeter 7A provides the following Setpoint parameters. Parameter 1 to 19 can be set with a shorter Active/Inactive Delay duration from 0.01s to 0.99s (i.e., 1/2 cycle to 49.5 cycles) for a high-speed setpoint action.

CET Electric Technology

ID	Parameter	Resolution	ID	Parameter	Resolution
0	Null	--			
Basic (~ Available in Firmware V2.50.08 or later)					
1	Uln	0.1V	101	U2 Unbalance	0.1%
2	Ull	0.1V	102	I0 Unbalance	0.1%
3	U4	0.1V	103	I2 Unbalance	0.1%
4	I	0.1A	104	U Fund.	0.1V
5	I4	0.1A	105	I Fund.	0.1A
6	Reserved	--	106	U Deviation	0.1%
7	P Total	0.1W	107	U Over Deviation	0.1%
8	Q Total	0.1var	108	U Under Deviation	0.1%
9	S Total	0.1VA	109	Frequency	0.01Hz
10	PF Total	0.001	110	Frequency Deviation	0.01Hz
11	U1	0.1V	212	Phase Loss	--
12	U2	0.1V	213	Phase Reversal	--
13	U0	0.1V	214	AI1	0.1
14	I1	0.1A	215	AI2	0.1
15	I2	0.1A	216	TC1	°C
16	I0	0.1A	217	TC2	°C
17	Rapid Freq. (HS Freq.)~	0.01Hz	218	2kHz-150kHz C.E.	0.1V
18	Freq. Deviation~	0.01Hz	219	Pst	0.1
19	Rate of Freq. Change~	0.01Hz/s	220	Plt	0.1
100	U0 Unbalance	0.1%	222	Reserved	--
Harmonics					
Harmonics Distortion					
111	U THD	0.1%	116	I TEHD	0.1%
112	U TOHD	0.1%	135	U TOHD	0.1%
113	U TEHD	0.1%	136	U TEHD	0.1%
114	I THD	0.1%	137	I TOHD	0.1%
115	I TOHD	0.1%	138	I TEHD	0.1%
Individual Harmonics Distortion					
0x20000	U HD02	0.1%	0x40000000	I HD02	0.1%
0x30000	U HD03	0.1%	0x41000000	I HD03	0.1%
...
0x3F0000	U HD63	0.1%	0x7D000000	I HD63	0.1%
Harmonics RMS					
123	U TH RMS	0.1V	126	I TH RMS	0.1A
124	U TOH RMS	0.1V	127	I TOH RMS	0.1A
125	U TEH RMS	0.1V	128	I TEH RMS	0.1A
Individual Harmonics RMS					
0x400000	U H02 RMS	0.1V	0x20000000	I H02 RMS	0.1A
0x410000	U H03 RMS	0.1V	0x30000000	I H03 RMS	0.1A
...
0x7D0000	U H63 RMS	0.1V	0x3F000000	I H63 RMS	0.1A
Interharmonics					
Interharmonics Distortion			Interharmonics RMS		
117	U TIHD	0.1%	129	U TIH RMS	0.1V
118	U TOIHD	0.1%	130	U TOIH RMS	0.1V
119	U TEIHD	0.1%	131	U TEIH RMS	0.1V
120	I TIHD	0.1%	132	I TIH RMS	0.1A
121	I TOIHD	0.1%	133	I TOIH RMS	0.1A
122	I TEIHD	0.1%	134	I TEIH RMS	0.1A
Individual Interharmonics Distortion			Individual Interharmonics RMS		
0x810000	U IHD01	0.1%	0x81000000	I IH01 RMS	0.1A
0x820000	U IHD02	0.1%	0x82000000	I IH02 RMS	0.1A
...
0xBF0000	U IHD63	0.1%	0xBF000000	I IH63 RMS	0.1A
Demand					
Present			Predicted		
200	P Total Imp. DMD	0.1W	206	P Total Imp. DMD	0.1W
201	Q Total Imp. DMD	0.1var	207	Q Total Imp. DMD	0.1var
202	P Total Exp. DMD	0.1W	208	P Total Exp. DMD	0.1W
203	Q Total Exp. DMD	0.1var	209	Q Total Exp. DMD	0.1var
204	S Total Exp. DMD	0.1VA	210	S Total Exp. DMD	0.1VA
205	PF Total DMD	0.001	211	PF Total DMD	0.001

Table 4-26 Setpoint Parameters

4.6 Data Logging

4.6.1 IER/AER

The iMeter 7A provides a fixed capacity of 65535 entries for both IER (Interval Energy Recorder) and AER (Accumulative Energy Recorder) Logs for the parameters specified in **Table 4-27 IER/AER Parameters**.

The IER records the amount of energy consumed during the last completed interval while the AER records a snapshot of the accumulated energy at the time of recording. The IER/AER Logs can only be retrieved through communications.

3-phase Total		
RMS kWh Import	RMS kvarh Import	kVAh Total
RMS kWh Export	RMS kvarh Export	
RMS kWh Net	RMS kvarh Net	
RMS kWh Total	RMS kvarh Total	
Fundamental kWh Import	Fundamental kvarh Import	
Fundamental kWh Export	Fundamental kvarh Export	
Harmonic kWh Import	Harmonic kvarh Import	
Harmonic kWh Export	Harmonic kvarh Export	
Per-phase		
kWh Import	kvarh Import	kVAh Total
kWh Export	kvarh Export	
kWh Net	kvarh Net	
kWh Total	kvarh Total	

Table 4-27 IER/AER Parameters

The IER/AER setup parameters, which include **Recording Mode**, **Recording Interval**, **Start Date** and **Start Time**, can be programmed from the Front Panel, Web Interface or communications. Please note that changing any of the setup parameters would reset the IER/AER Logs. The following table illustrates the range of the Energy Log parameters where * indicates the default value.

Parameter	Range/Default*	Parameter	Range/Default*
Interval/Accumulative Energy			
Record Mode	Disable, Stop When Full, FIFO*	Interval	1 to 65535 min, 15 min*
Start Date	2000-01-01*	Start Time	00:00:00*
Per-phase Interval/Accumulative Energy			
Record Mode	Disable*, Stop When Full, FIFO	Interval	1 to 65535 min, 15 min*
Start Date	2000-01-01*	Start Time	00:00:00*

Table 4-28 Energy Log Parameters

4.6.2 WFR (Waveform Recorder)

The iMeter 7A supports the waveform recording of 4-phase Voltages and Currents at a maximum resolution of 1024 samples/cycle. WFR on the iMeter 7A can be triggered by PQ Disturbance (Dips/Swells/Interruptions), Transients, Rapid Voltage Changes, Inrush Current, Setpoints, iTrigger, DI Status Changes or even manually triggered through the Front Panel, Web Interface and communications. The manual trigger command has a higher priority. When a WFR is already in progress, other WFR commands will be ignored until the present recording has completed. The WFR has a capacity of 128 entries organized on a FIFO basis, with the newest WFR log replacing the oldest one. The WFR log is stored in the device's non-volatile memory in COMTRADE file format and will not suffer any loss in the event of power failure.

The WFR log can be viewed directly on the Front Panel and Web Interface as well as downloaded from the on-board FTPS/Web Server or via communications. The programming of the WFR is supported via the Front Panel (Please refer to **Section 3.1.3.5.5**), Web Interface (Please refer to **Section 3.2.3.5.5.1**) or communications.

The following table illustrates the ranges and default values of the WFR parameters.

Parameter	Options/Range, Default*	Parameter	Options/Range, Default*
Pre-Fault Cycles	2-16 Cycles, 5*	No. of Cycles	Range of Cycles @ Samples/Cycle, 100* • (40-3200) @128 • (40-800) @ 512 • (40-1600) @ 256 • (40-400) @ 1024
Post-Fault Cycles			
Samples/Cycle			
Adaptive WFR			

Table 4-29 WFR Setup Parameters

The iMeter 7A also provides the following settings for Scheduled WFR to trigger the WFR on the hour as pre-configured. The programming of the Scheduled WFR is supported via the Web Interface or Communications.

Parameter	Options/Value, Default*	Parameter	Options/Value, Default*
Enable	Yes, No*	Interval	1 to 65535 min, 1440*
Recording Interval (Repetition)	0 to 10000, 1* (0 means disabled)	Start Date	2000-01-01*
		Start Time	00:00:00*

Table 4-30 Scheduled WFR Setup Parameters

4.6.3 DWR (Disturbance Waveform Recorder)

The iMeter 7A supports the Disturbance Waveform Recording of 4-phase Voltages and Currents at a maximum resolution of 512 samples/cycle. The DWR can be triggered by Dips, Swells, Interruptions, Transients, RVC, Inrush Current, Setpoints, iTrigger, DI Status Changes or even manually triggered via the Web Interface and communications. The DWR log is stored in the device’s non-volatile memory in COMTRADE file format and will not suffer any loss in the event of power failure. The DWR has a capacity of 128 entries organized on a FIFO basis, with the newest DWR log replacing the oldest one. Each DWR log consists of the following stages:

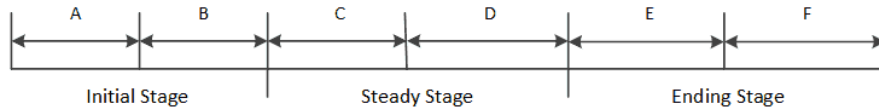
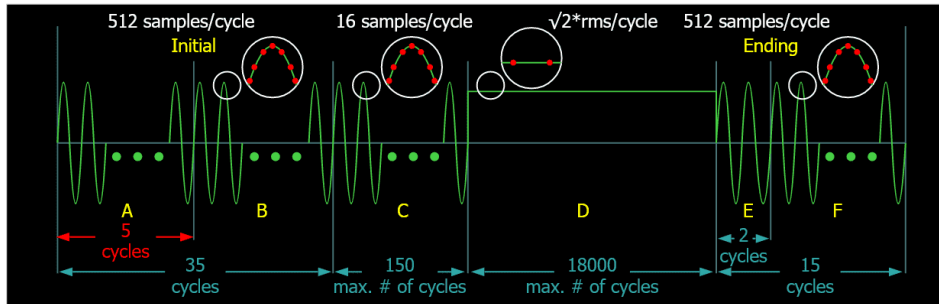

Figure 4-27 DWR Stages



Stage	Description	Recording Length	Recording Frequency
A	Pre-Fault cycles for the Initial Stage	5 to 10 cycles	512 Samples/Cycle
B	Post-Fault cycles for the Initial Stage	25 to 30 cycles	512 Samples/Cycle
C	Extended WFR during the Steady Stage	0 to 150 cycles	16 Samples/Cycle
D	RMS Recording during the Steady Stage	0 to 18,000 cycles	1 Sample/Cycle
E	Pre-Fault cycles of the Ending Stage	2 cycles	512 Samples/Cycle
F	Post-Fault cycles of the Ending Stage	13 cycles	512 Samples/Cycle

Table 4-31 Detailed Description of the DWR Stages

Notes:

- 1) The data for Stages A, B, E and F are always recorded.
- 2) For stages C and D:
 - If **C** < 150 cycles, then **D** would be 0.
 - If **C** = 150 cycles, then the data for stage **D** will be recorded.
 - If **D** = 18,000 cycles, the recording of the stage **D** data ends even if the disturbance is not finished.
- 2) The following figure shows an example of Disturbance Waveform Recording.

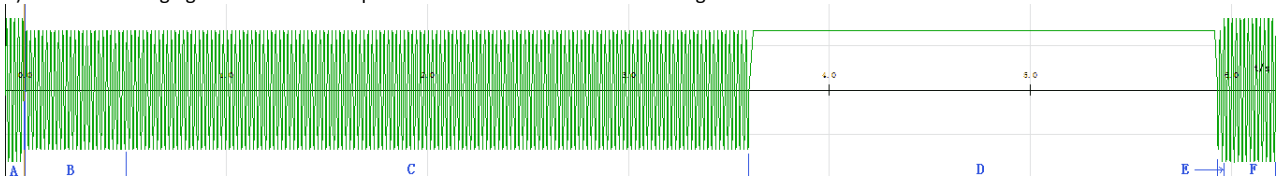

Figure 4-28 An Example of DWR

4.6.4 RMSR (RMS Recorder)

The iMeter 7A provides high-speed RMS recording which can be triggered by Dips, Swells, Interruptions, Transients, RVC, Inrush Current, Setpoints, iTrigger, DI status changes or manually via communications. The RMSR Logs are stored in the device’s non-volatile memory in COMTRADE file format and will not suffer any loss in the event of a power failure. The RMSR has a capacity of 128 entries on a FIFO basis.

All RMSR can be accessible via the on-board Web Server, FTPS Server or through communications by our PecStar® iEMS. The programming of the RMSR is supported via the Front Panel, Web Server or through communications.

The **Recording Width** for RMSR is fixed at 7200 samples per parameter. The following table illustrates the ranges and default values for the RMSR parameters.

Parameter	Options/Value, Default*	Parameter	Options/Value, Default*
Pre-fault Samples	100 to 500, 300*	Sample Interval	0 to 60, 0* (0 represents 0.5 cycle)

Table 4-32 RMSR Parameters

Table 4-33 below illustrates the available source parameters for RMSR recording.

ID	Parameter	ID	Parameter	ID	Parameter	ID	Parameter
0	Null	9	Ic	18	Qb	27	Ull Avg.
1	Ua	10	U4	19	Qc	28	I Avg.
2	Ub	11	I4	20	Sa	29	P Total
3	Uc	12	Frequency	21	Sb	30	Q Total
4	Uab	13	Freq. Dev.	22	Sc	31	S Total
5	Ubc	14	Pa	23	PFa	32	PF Total
6	Uca	15	Pb	24	PFb	33	Fast Freq. (HS Freq.)
7	Ia	16	Pc	25	PFc	34	Reserved
8	Ib	17	Qa	26	Uln Avg.		

Table 4-33 Available Parameters for RMSR

4.6.5 Pst Log

iMeter 7A’s Pst Log can store up to 52560 entries (i.e. 1-year: 365x24x6) about Voltage Pst in its non-volatile memory. Each record includes the timestamp in 1ms resolution, flagging status and the 3-phase Voltage Pst measurements.

The Pst Log can be retrieved via communications for display. If there are more than 52560 events, the newest event will replace the oldest event on a FIFO basis. The Pst Log can be reset from the Web Server (See **Section 3.2.3.5.10.2**) or via communications.

4.6.6 Plt Log

iMeter 7A’s Plt Log can store up to 4380 entries (i.e. 1-year: 365x12) about Voltage Plt in its non-volatile memory. Each record includes the timestamp in 1ms resolution, flagging status and the 3-phase Voltage Plt measurements.

The Plt Log can be retrieved via communications for display. If there are more than 4380 events, the newest event will replace the oldest event on a first-in-first-out basis. The Plt Log can be reset from the Web Server (See **Section 3.2.3.5.10.2**) or via communications.

4.6.7 SDR (Statistical Data Recorder)

The iMeter 7A provides 8 groups of SDRs of 64 parameters each to record the Max./Min./Average/CP95 measurements with a recording depth of 43200 and configurable recording interval from 0 (disabled) to 60 mins. The SDR Logs are stored in non-volatile memory and will not suffer any loss in the event of a power failure.

The programming of the **SDR** is supported via the Web Server or through communications. Each **SDR** provides the following setup parameters:

Setup Parameters	Range/Default*
Record Interval	0 (disabled) to 60 min, 10 min*
Record Mode	0=Stop-when-Full, 1=First-In-First-Out*
# of Parameters	0 (invalid) to 64, please refer to Section 5.17.17.2 for the default values
Parameter 1 to 64	See Appendix A

Table 4-34 Setup Parameters for SDR

The **SDR** is operational when the values of the **Record Interval** and **Number of Parameters** are both non-zero.

4.6.8 DR (Data Recorder)

The iMeter 7A provides 8 Data Recorders (**DR**) capable of recording 64 parameters each. The recorded data is stored in non-volatile memory and will not suffer any loss in the event of a power failure.

The programming of the Data Recorder is supported via the on-board Web Server or through communications. Each Data Recorder provides the following setup parameters:

Parameter	Options/Range, Default*
Triggered Mode	Disabled, Triggered by Timer*, Triggered by Setpoint
Recording Interval	0 to 3,456,000 (seconds), 900*
Recording Mode	Stop-When-Full, First-In-First-Out*
Offset Time	0* (no offset) to 43200 If the Trigger Mode is set to Triggered by Setpoint , the Offset Time will be disregarded.
Parameters	Please refer to Appendix A

Table 4-35 Setup Parameters for DR

The DR Log is only operational when the values of **Triggered Mode**, **Recording Mode** and **Recording Interval** are all non-zero.

Data Recorder #X can be triggered by clearing the Data Recorder #X when it is full in Stop-When-Full mode.

The **Recording Offset** parameter can be used to delay the recording by a fixed time from the **Recording Interval**. For example, if the **Recording Interval** parameter is set to 3600 (hourly) and the **Recording Offset** parameter is set to 300 (5 minutes), the recording will take place at 5 minutes after the hour every hour, i.e. 00:05, 01:05, 02:05...etc. The programmed value of the **Recording Offset** parameter should be less than that of the **Recording Interval** parameter.

4.6.9 Max./Min. Recorder

The iMeter 7A provides 4 **Max./Min. Recorders** of 20 parameters each for **This Month (Since Last Reset)** and **Last Month (Before Last Reset)**. Each log includes the relevant Max./Min. values and timestamps. The recorded data is stored in non-volatile memory and will not suffer any loss in the event of a power failure.

The programming of the Max/Min recorders is supported via Web Server or through communications. Each Max./Min. recorder provides the following setup parameters:

Parameters	Value
Self-Read time	The same Self-Read Time for the Max. Demand Recorder is used to specify the time and day of the month for the Max./Min. Self-Read operation. Please refer to Section 4.2.4.2 for a complete description of the Self-Read Time and its operation.
# of Parameters	0 to 20
Parameter 1 to 20	See Appendix A

Table 4-36 Setup Parameters for Max./Min. Log

The Front Panel supports the display for This Max/Min logs since the last reset.

Both This Max/Min logs and the Last Max/Min logs can be accessed via web server or through communications. And the Max./Min. logs can be reset via Front Panel or Web Interface.

4.6.10 SOE Log & Device Log

The SOE and Device Logs can be retrieved via the Front Panel, Web Interface or communications.

The SOE Log and Device Log can be reset via the Front Panel and Web Server with the **Clear All Events** option.

The following sections address the basic properties of the SOE Log and Device Log.

4.6.10.1 SOE Log

The SOE Log can store up to 1024 events such as Setpoints, Digital Input status changes, Relay actions, Dips, Swells, Interruptions, Transient, Inrush Current, Rapid Voltage Changes, Motor Start and iTrigger based on a First-In-First-Out principle. Each event record includes the event classification, its relevant parameter values and a timestamp in 1ms resolution.

Please refer to **Appendix C** for the SOE Classification.

4.6.10.2 Device Log

The Device Log can store up to 1024 events such as Power-on, Power-off, Setup Changes, Clear operations and TOU Schedule Switch in its non-volatile memory on a FIFO basis. Each event record includes the event classification, its relevant parameter values and timestamp in 1ms resolution.

Please refer to **Appendix B** for the Device Log Classification.

4.6.11 PQ Counters

The iMeter 7A supports the counting of the different PQ Events as illustrated in Table 4-37 below. When a particular event is detected, the corresponding counter will be incremented by one. The maximum value of the PQ Counter is $2^{32}(4,294,967,296)$, and it will automatically roll over to 0 when the maximum value has been reached. The counter can be reset from the Front Panel, Web Server or communications.

No	Event	No	Event	No	Event
1	Dip	5	Rapid Voltage Change	9	MSV#3
2	Swell	6	Inrush Current	10	Total
3	Interruption	7	MSV#1		
4	Transient	8	MSV#2		

Table 4-37 PQ Event Counter

4.7 iTrigger

The WFR/DWR/RMSR/DO of iMeter 7A can be cross-triggered with by other iTrigger-enabled devices residing on the same subnet of the LAN (Local Area Network) and configured with the same iTrigger Group ID. The Actions can be configured as WFR, DWR, RMSR and/or DO via the Web Interface.

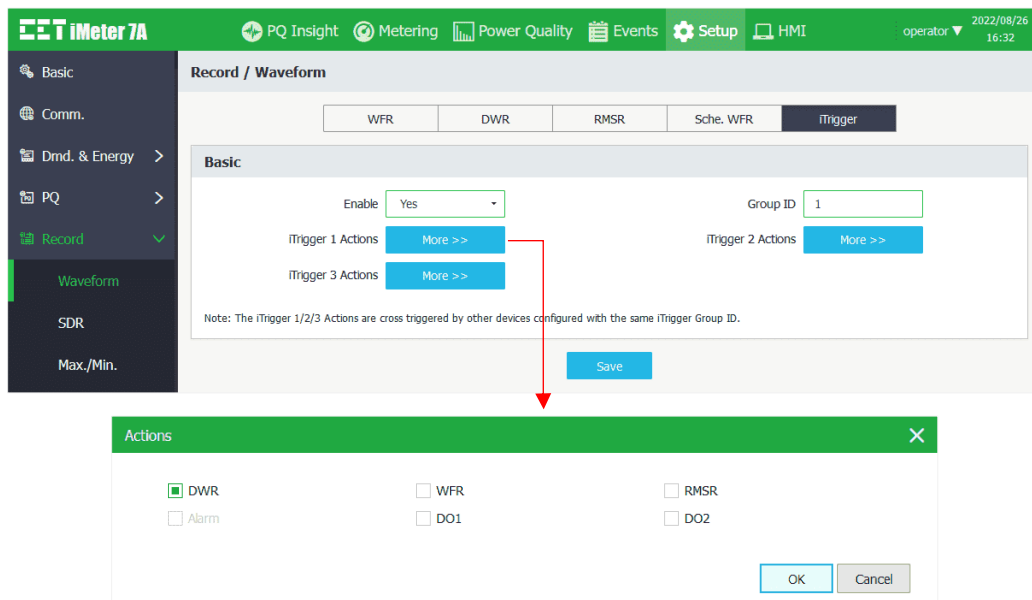

Figure 4-29 iTrigger Settings Interface via Web Interface

As a result, the iMeter 7A provides Source MAC Address and Source Group ID in its SOE details.

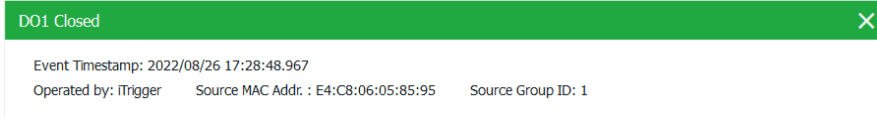

Figure 4-30 Trigger Source

Vice versa, the iMeter 7A can also cross-trigger other iMeter’s iTrigger when it is triggered manually or by a Setpoint (control setpoint, PQD setpoint and etc.) with iTrigger 1, 2 and/or 3 set as the Trigger Actions.

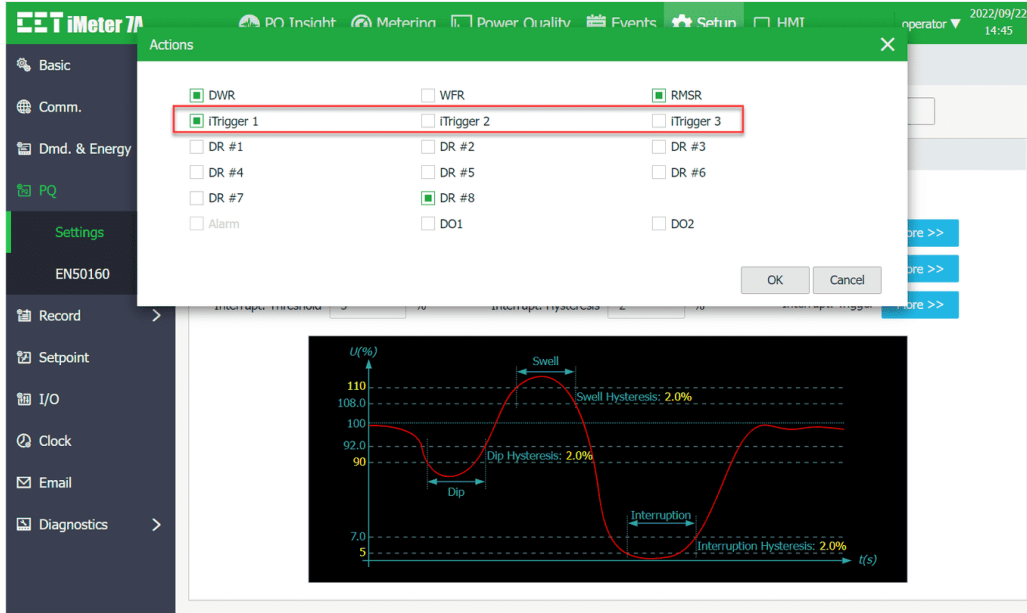

Figure 4-31 Configure iTrigger as PQD Trigger Actions on iMeter 7A

4.8 Time of Use (TOU)

TOU is used for electricity pricing that varies depending on the time of day, day of week and season. The TOU system allows the user to configure an electricity price schedule with accumulated energy consumption into different TOU tariffs based on the time of consumption.

The TOU feature supports two TOU schedules, which can be switched at a pre-defined time. Each TOU schedule supports:

- Up to 12 seasons
- 90 Holidays or Alternate Days
- 20 Daily Profiles, each with 12 Periods in 15-minute intervals
- 8 Tariffs

Instead of using the TOU schedule to switch between Tariffs, the iMeter 7A supports Tariff switching based on the status of DI1 to DI3.

The 3 Digital Inputs (DI1, DI2 and DI3) represent 3 binary digits where Tariff 1=000, Tariff 2=001, Tariff 3=010, ...Tariff 7=110 and Tariff 8=111 where DI1 represents the least significant digit and DI3 represents the most significant digit. As soon as DI1, DI2 and/or DI3 are configured as **Tariff Switches**, the current **TOU Tariff** will be determined by the status of the DIs and the TOU Schedule will be ignored. The **DI1 Function** setup register must first be programmed as a **Tariff Switch** before configuring DI2 and DI3 with the same function. In other words, if DI1 is configured as a **Status Input** or **Pulse Counter** and DI2 is configured as a **Tariff Switch**, the TOU will continue to function based on the TOU Schedule. The number of Tariffs supported depends on how many DIs are programmed as a Tariff Switch as indicated in the following table.

Tariff	DI Function		
	DI1 = Tariff Switch	DI2 & DI1 = Tariff Switch	DI3, DI2 & DI1 = Tariff Switch
T1	DI1 (0=T1)	DI2 + DI1 (00=T1)	DI3 + DI2 + DI1 (000=T1)
T2	DI1 (1=T2)	DI2 + DI1 (01=T2)	DI3 + DI2 + DI1 (001=T2)
T3	Not Available	DI2 + DI1 (10=T3)	DI3 + DI2 + DI1 (010=T3)
T4	Not Available	DI2 + DI1 (11=T4)	DI3 + DI2 + DI1 (011=T4)

T5	Not Available	Not Available	D13 + D12 + D11 (100=T5)
T6	Not Available	Not Available	D13 + D12 + D11 (101=T6)
T7	Not Available	Not Available	D13 + D12 + D11 (110=T7)
T8	Not Available	Not Available	D13 + D12 + D11 (111=T8)

Table 4-38 DIs and the Number of Tariffs Setup

Each TOU schedule has the following setup parameters and can be programmed via the Web Server or communications:

Parameters	Definition	Options
Daily Profile #	Specify a daily rate schedule which can be divided into a maximum of 12 periods in 15-min intervals. Up to 20 Daily Profiles can be programmed for each TOU schedule.	1 to 20, the first period starts at 00:00 and the last period ends at 24:00.
Season #	A year can be divided into a maximum of 12 seasons. Each season is specified with a Start Date and ends with the next season's Start Date.	1 to 12, starting from any date.
Alternate Days #	A day can be defined as an Alternate Day, such as May 1 st . Each Alternate Day is assigned a Daily Profile.	1 to 90.
Day Types	Specify the day type of the week. Each day of a week can be assigned a day type such as Weekday1, Weekday2, Weekday3 and Alternate Days. The Alternate Day has the highest priority.	Weekday1, Weekday2, Weekday3 and Alternate Days
Switching Time	Specify when to switch from one TOU schedule to another. Writing 0xFFFFFFFF to this parameter disables switching between TOU schedules.	Format: YYYYMMDDHH Default=0xFFFFFFFF

Table 4-39 TOU Setup Parameters

For each of the 8 Tariff Rates, the iMeter 7A provides the following measurements: kWh Import/Export, kvarh Import/Export, kVAh, P/Q/S Max. Demand with their timestamps. All these data are available via the Front Panel, Web Interface, and communications. The TOU Logs can be reset through the Web Server or via communications.

4.9 Time Synchronization

The iMeter 7A provides timestamps for all recorded data so it's extremely important for the clock to be properly synchronized to achieve precise time stamping for Energy, Power Quality and Event analysis. The iMeter 7A supports time synchronization with auto-selection among RTC, Modbus RTU, NTP, GPS 1PPS, IRIG-B and IEEE 1588 (PTP) for best precision.

The iMeter 7A displays the Time Sync. status with Clock Source and the difference between the meter clock and the GPS receiver/PTP Grand Master.

Self Diagnostics	
Self Diagnostics	Normal
Wiring Status	Normal
Temperature	34.00°C
Time Sync.	Synced (Clock Source: NTP, Diff.: 0.22ms)
Cloud	Offline
Memory	4804MB Available (Total 6196MB)

Figure 4-32 Time Sync. Status

The different time sync. options are discussed in the following sections.

4.9.1 RTC

The iMeter 7A is equipped with a 6ppm, battery-backed real-time clock that has a maximum error of 0.5s per day. If the supply power is lost or removed, the internal backup battery keeps the real-time clock running until power is restored.

4.9.2 GPS

GPS receivers often provide a 1PPS (1 Pulse per Second) output which the iMeter 7A can be connected to synchronize its millisecond clock via its Clock Input terminals. Please refer to Figure 2-16 for the 1PPS wiring diagram. An incoming PPS signal on an input time synchronization connector can be repeated to one or two output time synchronization. The iMeter 7A can automatically detect and accept both RS-485 and RS-232 signals from the GPS receiver.

Only the precise PPS second tick is transmitted over the cabling, the time-of-day information shall be provided via another communication path, for example, Modbus RTU over RS-485 or NTP over Ethernet.

4.9.3 IRIG-B

The IRIG-B time codes, originally developed by the Inter-Range Instrumentation Group (IRIG), is a standard format for transferring serial timing information once a second. IRIG-B has a pulse rate of 100 pulses per second.

The iMeter 7A accepts an IRIG-B signal as a time source to provide a precision time reference. The iMeter 7A can automatically detect the RS-485 differential signal carrying the IRIG-B full date/time information via its Clock Input terminals. Please refer to Figure 2-15 for the wiring. The IRIG-B time source (i.e., GPS receiver/clock) shall support **IEEE C37.118** (also called **IEEE 1344 Extensions**) for time code.

Since the UTC time is transported by the IRIG-B frame, the **IRIG-B Time Zone** can be used to determine the Local Time for the iMeter 7A providing the meter and the time source are in the same time zone. The programming of the IRIG-B Time Zone is supported via the Front Panel, Web Interface or through Communications.

4.9.4 IEEE 1588 (PTP)

IEEE 1588v2 Precision Time Protocol depends on time-stamped frames exchanged between a timing master clock and a timing slave clock, with intermediate boundary and/or transparent clocks to maintain the time accuracy in the sub-microsecond range.

The iMeter 7A supports the PTP time synchronization over its dual Ethernet ports, P1 and/or P2 with a maximum error of 200us.

The related terms and parameter definitions are described as follows:

Master – Clocks are typically synchronized to a master clock whose time is accurate, stable and traceable to a known standard (usually GPS).

Slave – Slave devices are remote from the Master and are synchronizing with it.

Domain Number – PTP provides for scalability by allowing each PTP clock group to be assigned to a logical group called a domain. The domain number is an integer from 0 to 127, with a default value of 0.

Protocol – PTP supports network transport over Layer 2 (802.3), or Layer 3 (UDP/IPv4).

PTP Priority 1 – A configurable clock priority for the Master-Slave Hierarchy. A clock with a lower value has a higher priority. 255 for Slave-only clock.

PTP Priority 2 – A configurable second-order clock priority.

PTP Delay – The iMeter 7A only supports a peer-to-peer mechanism.

Parameters	Options	Default
Enable	0=Disabled, 1=P1, 2=P2, 3=P1 & P2	Disabled
Protocol	0=PTP over UDP, 1=PTP over 802.3	PTP over UDP
Domain	0 to 127	0
PTP Priority 1 / 2	0 to 255	255

Table 4-40 Setup Parameters for IEEE 1588

The programming of the **IEEE 1588** setup parameters is supported via the Front Panel, Web Server or communications.

4.9.5 NTP

NTP (Network Time Protocol) can be used to synchronize the iMeter 7A's clock with an external **NTP Server** through its Ethernet port providing that the network has been properly configured. The programming of the **NTP Server** is supported via the Front Panel, Web Server, or communications.

4.9.6 Modbus RTU/TCP

The iMeter 7A's clock can be synchronized through communications using the Modbus RTU /TCP protocol. Please refer to **Section 5.19** for a detailed description.

4.9.7 PecStar iEMS

PecStar® iEMS can be configured to provide regular time synchronization by broadcasting time-sync packets over the connected medium, whether it is RS-485 or Ethernet. The default time synchronization interval is 60 minutes. Please consult the PecStar iEMS's user manual for a complete description.

4.10 Alarm Email (SMTP)

iMeter 7A can be configured to send Alarm Emails based on the Simple Mail Transfer Protocol (SMTP), which may be triggered by Setpoints, Dips, Swells, Interruptions, Transients, etc.

The Alarm Email provides the following information in a text format:

- 1) iMeter 7A's serial number and an event counter indicating the number of events in the email
- 2) Event Description and Characteristic values
- 3) Event timestamp

The programming of the Alarm Email setup parameters is supported via the Web Server and communications. The iMeter 7A provides the following SMTP setup parameters:

Parameters	Definition/Option
SMTP Server	IP/domain name of the SMTP Server, e.g., smtp.gmail.com (up to 31 characters long).
SMTP IP Port	0 to 65535 (Default=25)
Username	The Username should not exceed 39 characters.
Password	Login password for the sender's email address. This string is up to 19 characters long.
Sender Email	Sender's Email Address. This string is up to 39 characters long.
Receiver Email	Receiver's Email address. This string is up to 89 characters long. Different receivers should be separated by the ";" symbol. For example, xxxx@gmail.com; xxxx@outlook.com
SSL/TLS Enable	Enable the Secure Socket Layer encryption protocol for SMTP - Yes/No.
Trigger Source	System, Setpoint, I/O, Record, Dip/Swell, Transient, Inrush Current, RVC, MSV, Motor Start, EN 50160

Table 4-41 Email Setup Parameters

Here is an example of how to configure a PQ Disturbance to trigger an Alarm Email.

1. Click on **Setup-> PQ -> Settings** as shown below. Enable the PQ Disturbance detection and configure the Threshold, and Hysteresis properly.

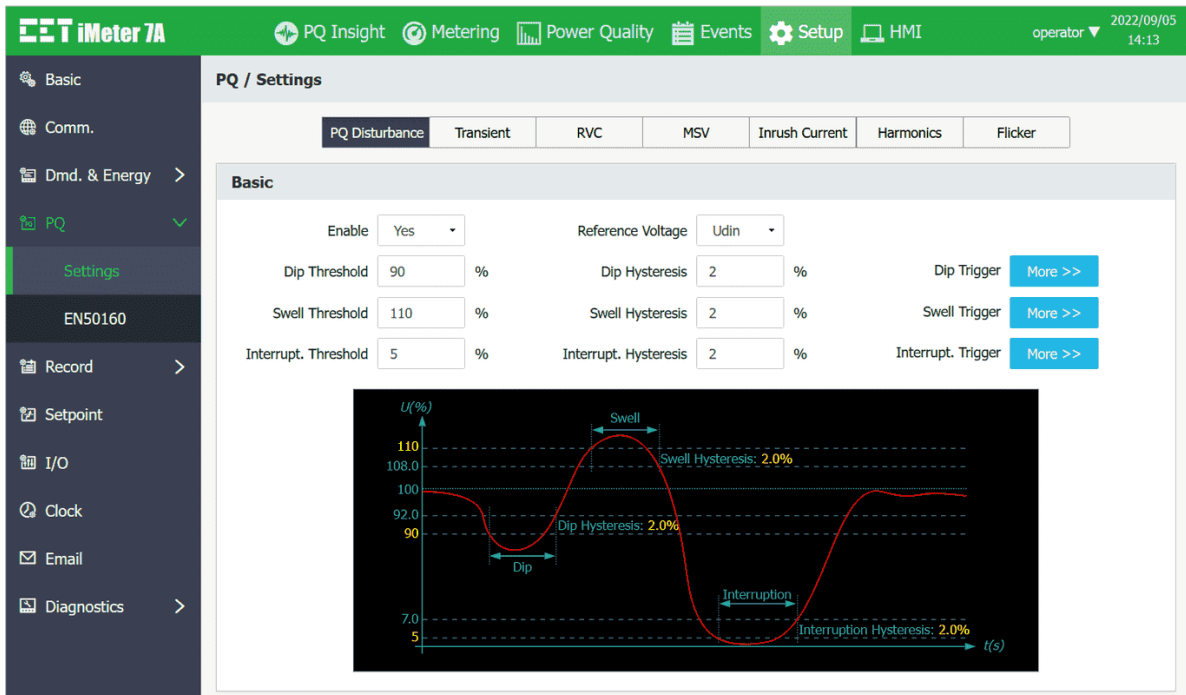

Figure 4-33 Setpoint Settings

- Click Setup-> Comm.-> Basic as shown below. Please configure the IP Address, Subnet Mask, Gateway and DNS Server properly to make sure the meter can be connected to the Internet.

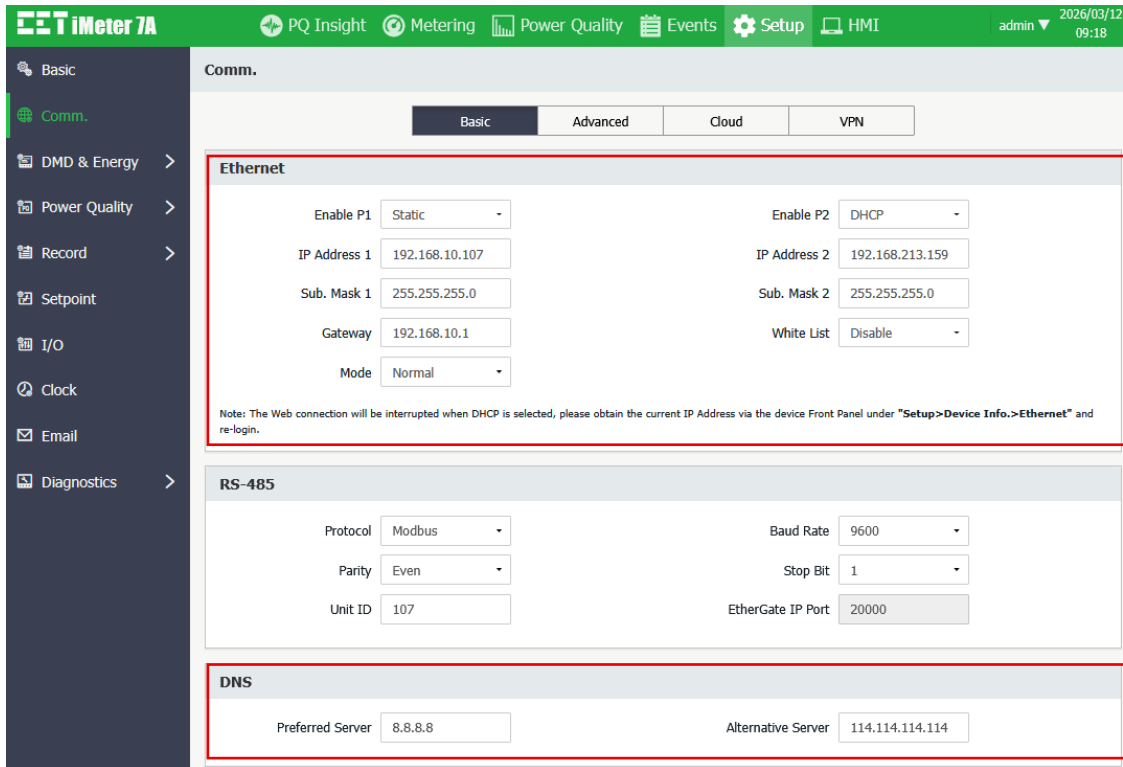

Figure 4-34 Communication Settings Interface

- Click on **Setup-> Others-> Alarm Email-> Settings** as shown below. Please note that all the SMTP information should be entered correctly (please log into the Sender Email account to confirm the SMTP settings).

Please refer to Google’s official documentation for 2-Step Verification and App Passwords at [Use app passwords with apps that don't support 2-step verification.](#)

Please refer to Microsoft’s official documentation for Two-step verification and App Passwords at [Manage app passwords for two-step verification.](#)

Here are two examples of the SMTP configuration for Gmail and Outlook.

For Gmail:

SMTP Server – smtp.gmail.com

SMTP IP Port – 465

Sender E-mail – example@gmail.com

Receiver Email – ****@***.com

SSL Enable – Yes

Password – Please see the following guide (the Google account password could not work due to the verification mechanism of Google).

- a. Please log into **Google Account** and under **Security** settings, ensure the 2-Step Verification is turned on as Google suggested.

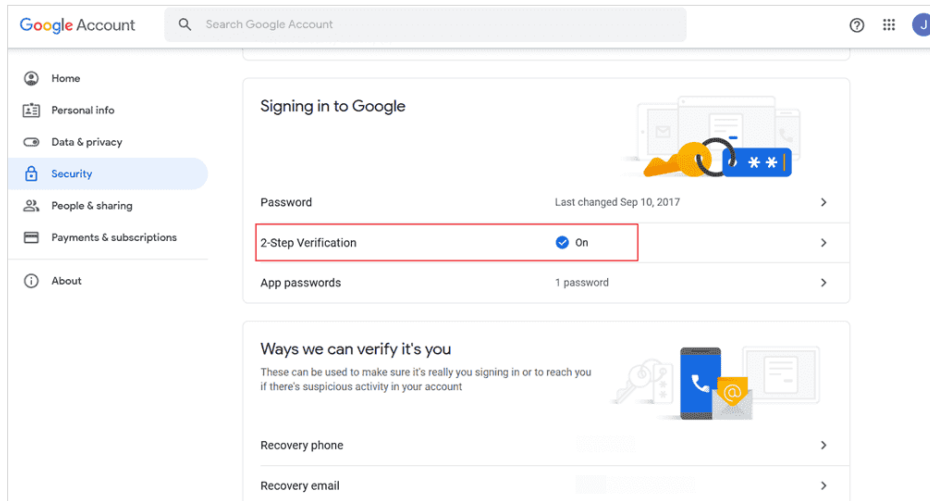

Figure 4-35 2-Step Verification on Google Account

- b. Since iMeter 7A doesn't support **2-Step Verification** with web direction to Gmail, please create an item under **App passwords** (under **2-Step Verification** in the above figure), and Google will provide you with a 16-character app password. Please use this app password in the SMTP configuration of iMeter 7A.

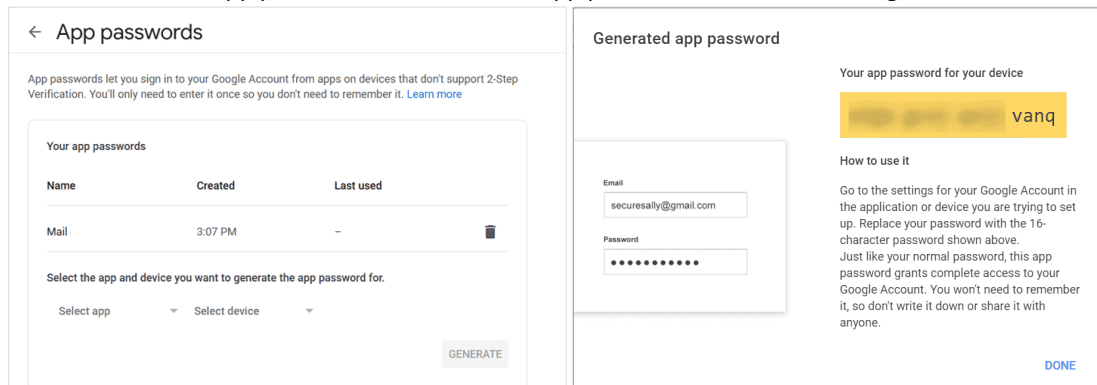

Figure 4-36 Retrieve App Password for Google Account

For Outlook:

SMTP Server – smtp.office365.com

SMTP IP Port – 587

Sender E-mail – example@outlook.com

Receiver E-mail – ****@***.com

SSL Enable: No (Outlook uses STARTTLS for SMTP service so there is no need to enable SSL).

Password: Please see the following guide (Similarly, the password of Outlook account could not work due to the Verification mechanism of Microsoft).

- a. Please log into **Microsoft account** and go to **Advanced security options** under the **Security** tab.

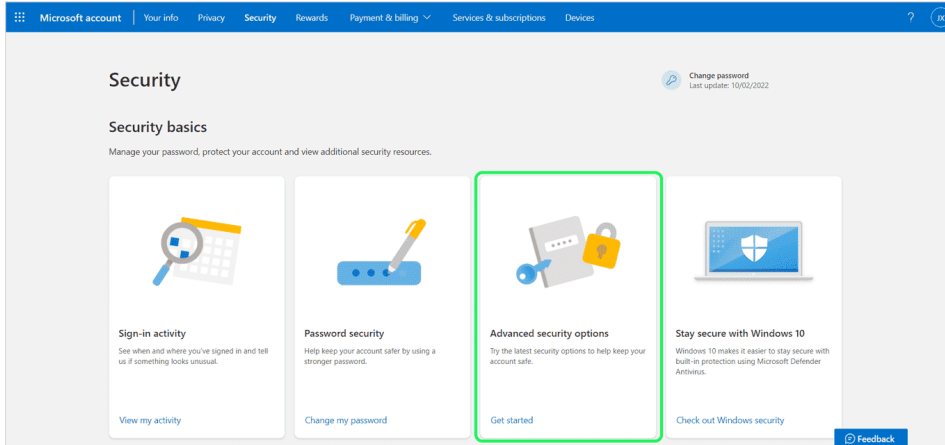

Figure 4-37 Security Setting for Microsoft Account

- b. Ensure the **Two-step verification** is turned on as Microsoft suggested. Create a new app password under **App passwords**. Please use this provided App password in the SMTP configuration of iMeter 7A.

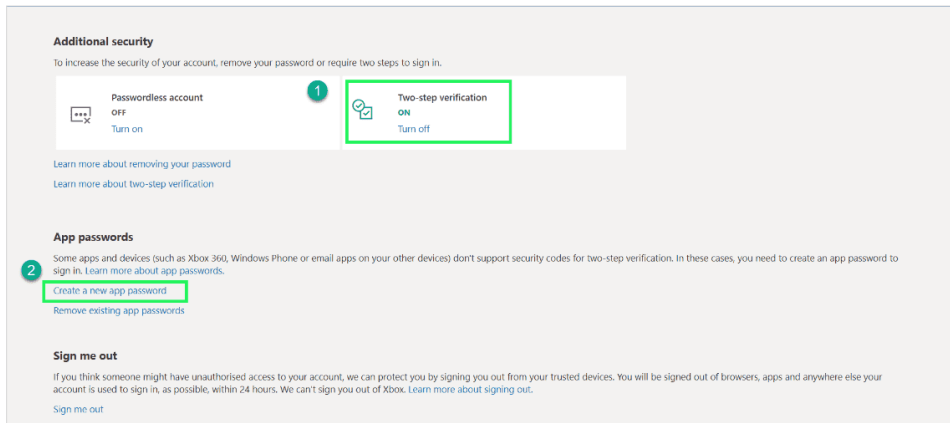

Figure 4-38 Retrieve App Password for Microsoft Account

2. Enter the App Password created from the Google or Microsoft account into the Password setting. Click **Save** to store the configuration in the iMeter 7A. The message “**Set Succeeded**” will appear if the configuration is accepted by the meter.

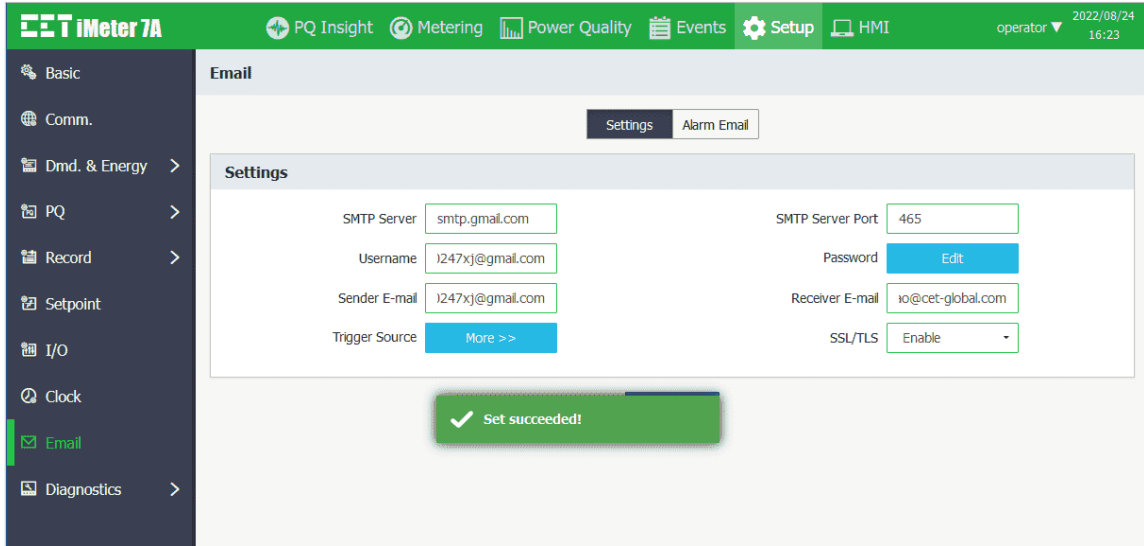

Figure 4-39 Alarm Email Setting via Web Server

4. Select the **Alarm Email** tab to send a Test Email by clicking on **Test**. The message “Email has been sent to the specified address” will appear if a test email has been successfully sent to the Receiver. However, if the Receiver didn’t receive the test email, the Alarm Email settings should be verified to make sure that they are correct and the iMeter 7A should be checked that it is connected to the Internet.

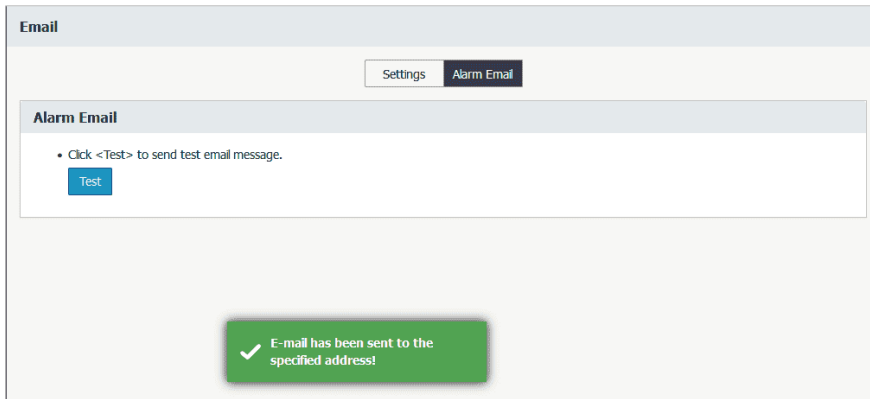

Figure 4-40 Send Test Email



Figure 4-41 An Example of Test Email

- If the Receiver receives the test email successfully, please return to **Alarm Email Settings** and click on **“More >>”** to open the **Trigger Source** dialog box. Check the Setpoint selection box and click **OK** to confirm the changes. Click **Save** to keep the changes.

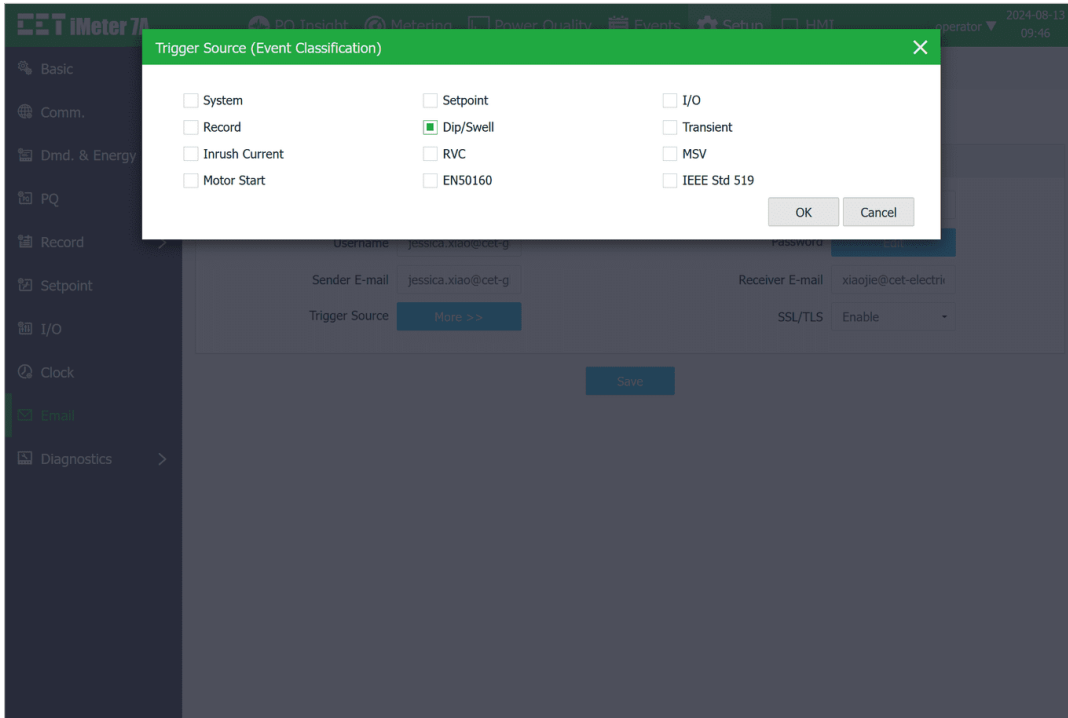

Figure 4-42 Trigger Source Dialog

- When the Setpoint is activated, an Alarm Email will be sent to the Receiver by the iMeter 7A, providing the SMTP configuration is correct.

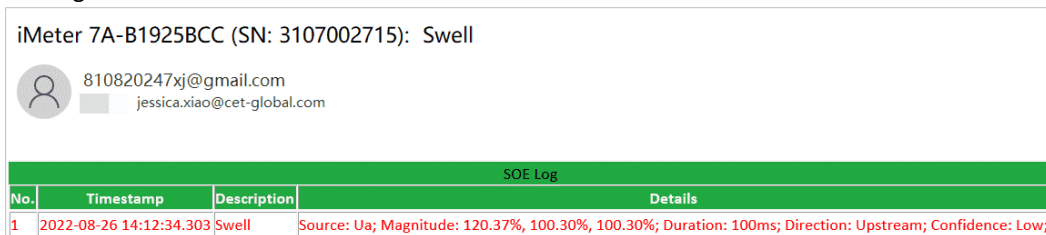

Figure 4-43 Alarm Email

4.11 Ethernet Gateway

The iMeter 7A's **Ethernet Gateway** feature supports the gateway function for Modbus communications between the Master Software (e.g. PecStar iEMS) on a Local Area Network and other RS-485-enabled devices (e.g. PMC-53A) via the iMeter 7A's Ethernet (P1/P2) and RS-485 ports (P3). This eliminates the need for an additional, external Ethernet-to-RS-485 Gateway, simplifies the overall network design and saves cost. The Master Software sends a "Modbus RTU over TCP/IP" packet (Modbus RTU packet, i.e. the payload, encapsulated in a TCP/IP frame) to the iMeter 7A's Ethernet port at its IP Address and the default IP Port No. 20000. The iMeter 7A receives this "Modbus RTU over TCP/IP" packet at its Ethernet port, extracts the "encapsulated" Modbus RTU packet, i.e. the payload, from the TCP/IP frame and then in turn forwards it to its RS-485 port. The RS-485-enabled device receives the Modbus RTU packet and sends its response back to the iMeter 7A, which in turn encapsulates the Modbus RTU response packet in a TCP/IP frame and then sends it back to the Master Software over Ethernet to complete the transaction.

The following illustrates the steps of configuring the iMeter 7A's Ethernet Gateway via P1:

- 1) Go to **Setup-> Basic-> Comm.-> RS-485** to change the **Protocol** setup parameter from the default setting of **Modbus** to **Gateway**, either via the Web Interface or Front Panel.

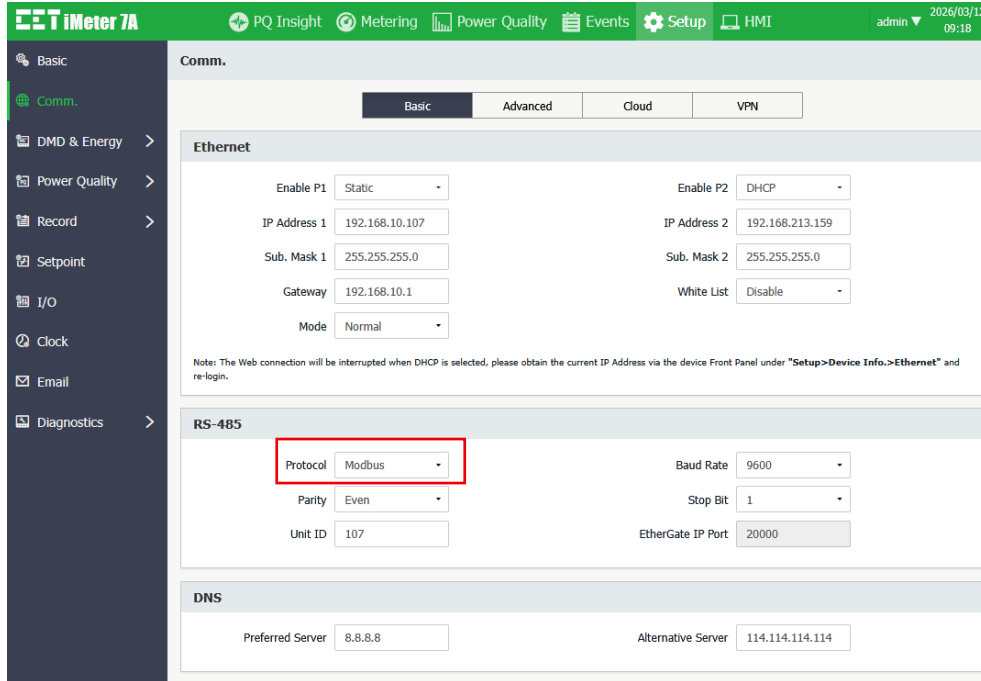

Figure 4-44 Select “EtherGate” Mode on the Web Server

- 2) Connect the RS-485-enabled devices (i.e. PMC-53A) to the RS-485 port of the iMeter 7A.

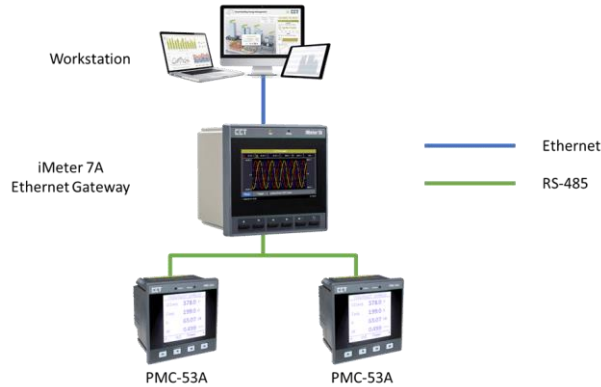

Figure 4-45 Typical Application for Ethernet Gateway

- 3) Configure the Master Software (e.g. PecStar iEMS) on the WorkStation to communicate with the RS-485-enabled devices via iMeter 7A’s Ethernet port at IP port No. 20000. It should be noted that the Master Software must support the **Modbus RTU over TCP/IP** protocol for this to work.
- 4) Make sure the serial port settings such as Baud Rate and Data Format are identical between the iMeter 7A’s RS-485 port and the RS-485-enabled devices.
- 5) The Master Software should be able to communicate with the RS-485-enabled devices via the iMeter 7A’s Ethernet Gateway, providing that all the necessary configuration is correct.

4.12 SNMP

4.12.1 Overview

Simple Network Management Protocol (SNMP) is widely used in Network Management Systems (NMS) to monitor and manage network devices for conditions that deserve administrative attention.

There are three main components in an SNMP-managed network: Network Management System, Agent and Managed Device.

- A **Network Management System (NMS)** is a piece of software or hardware that executes applications to monitor and control network devices. It serves as the human-machine interface in an SNMP-managed network.
- An **Agent** is a software module that resides in a managed device and serves as an interface between NMS and the physical device.
- A **Managed Device** is a network node that resides on a managed network and contains an SNMP agent. Managed devices collect and store information which is then made available to NMS via SNMP.

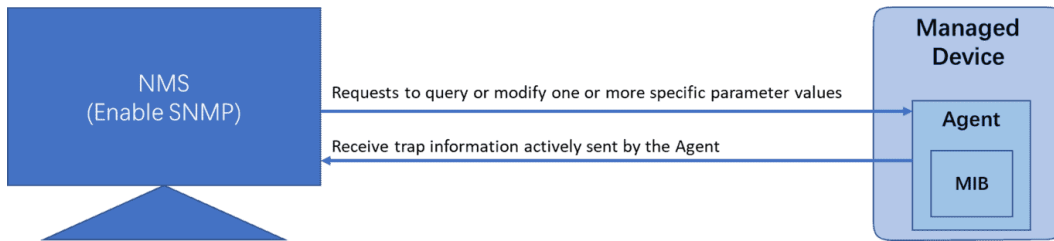

Figure 4-46 SNMP Structure

iMeter 7A’s basic measurements can be read and sent via SNMP. In addition, event records can be sent to an NMS in Trap format. The iMeter 7A provides the following information via SNMP.

	Parameters
Device Info.	Device Name, Firmware Version, Firmware Date, Device SN, Device Temperature, Self-diagnostic, Total Memory, Available Memory, Device Model
Status	Setpoint Status, DI Status, DO Status
Real-time Data	Primary Ua/Ub/Uc/Uln Avg. RMS, Primary Uab/Ubc/Uca/Ull Avg. RMS, Primary Ia/Ib/Ic/I Avg. RMS, Primary I4/U4 RMS, Pa/Pb/Pc/P Total RMS, Qa/Qb/Qc/Q Total RMS, Sa/Sb/Sc/ S Total RMS, Pfa/Pfb/Pfc/PF Total RMS, TC1, TC2, AI1, AI2
Energy Data	Σ kWh Import/Export/Net/Total, Σ kvarh Import/Export/Net/Total, Σ kVAh
Harmonic Distortion	Ua/Ub/Uc/U4/Ia/Ib/Ic/I4 THD, TOHD, TEHD, Ua/Ub/Uc HD00 to HD63

Table 4-42 Data Provided by the iMeter 7A via SNMP

4.12.2 Using SNMP

This section provides the guideline for communicating with the iMeter 7A in SNMP protocol using MG-SOFT MIB Browser as the NMS software. It’s assumed that the reader is somewhat familiar with SNMP.

Please execute the steps below.

1. Enable the SNMP service on the iMeter 7A via the Web Interface under **Setup -> Comm. -> Advanced** menu.

Figure 4-47 Enable SNMP

- Download the MIB definition (source) file for iMeter 7A from [here](#) and save it to the **SMI** folder under the installation path of MG-SOFT.

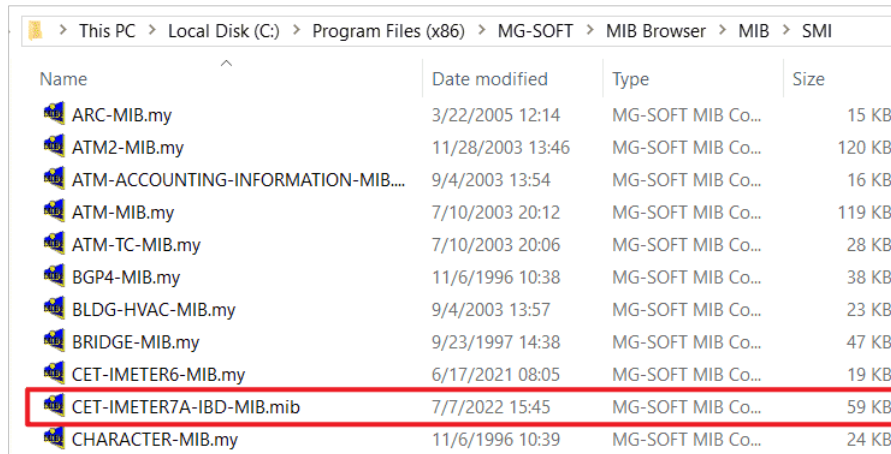

Figure 4-48 Save the MIB Definition File to SMI Folder

- Run the **MIB Compiler**. Click on in the toolbar and select the CET-IMETER7A-IBD-MIB.my file to compile.

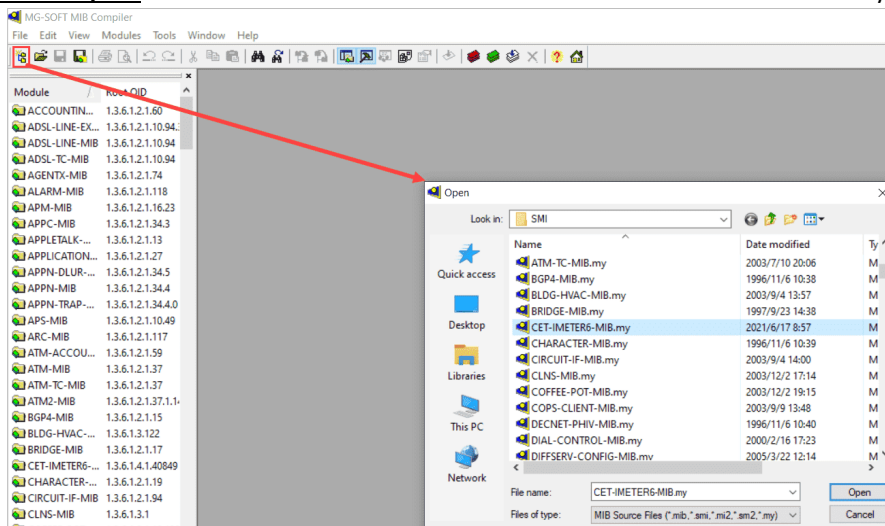

Figure 4-49 Compiler MIB Definition File

- After a successful compilation, the Compiled MIB Modules dialog box appears which allows the user to save the compiled MIB file.

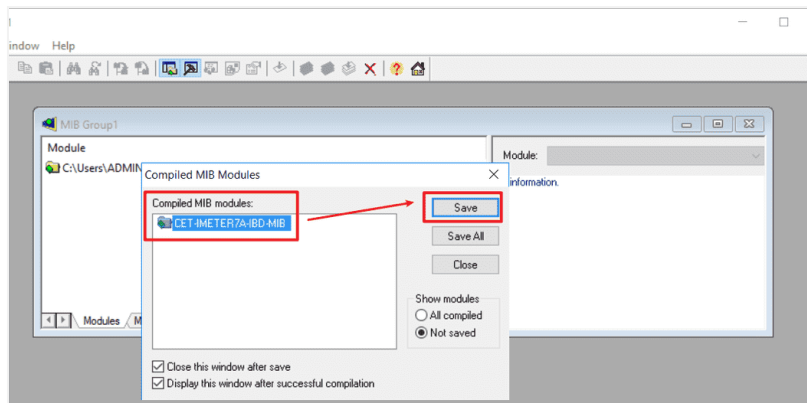

Figure 4-50 Compiled MIB Modules dialog box

The **Save As** dialog box appears to prompt the user where to save the compiled file. It's recommended to save the file to the default folder of the MIB Browser.

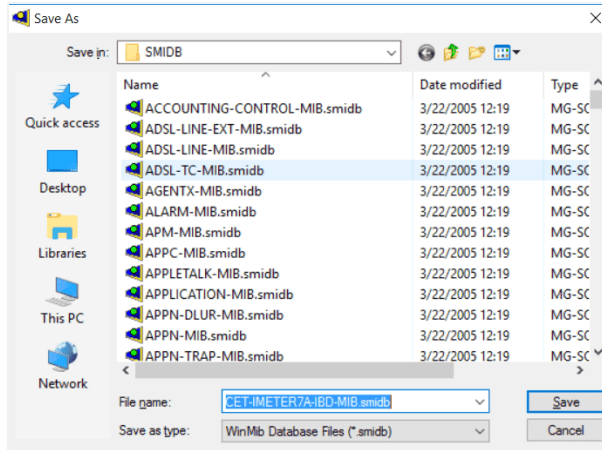



Figure 4-51 Save the Compiled File

- Run the MIB Browser as Administrator. Click the **MIB** tab and select CET-IMETER6-MIB in the **MIB Modules** window and click  to upload the selected MIB module.

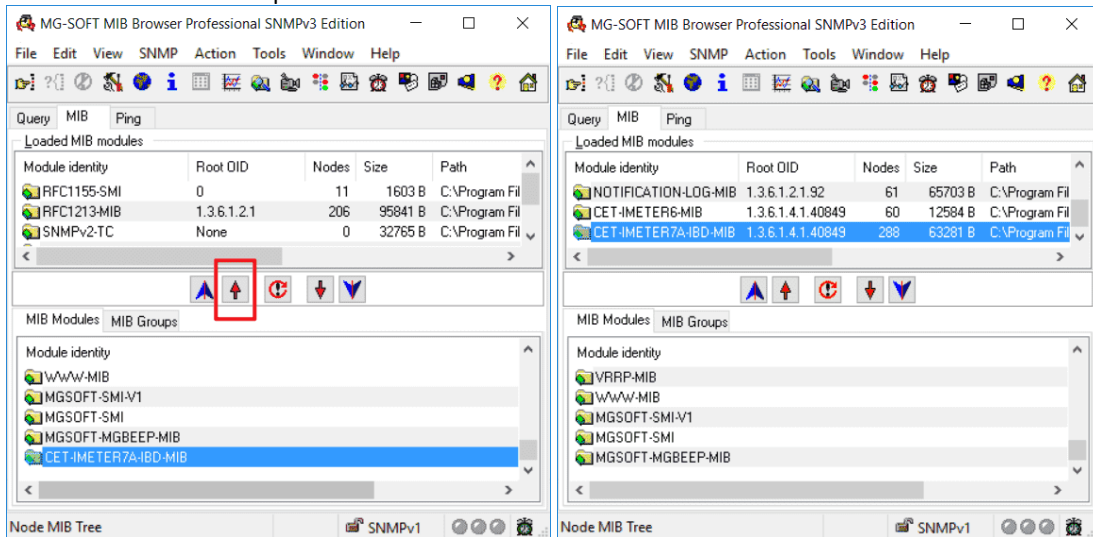



Figure 4-52 Upload MIB Module

- Click the **Query** tab and enter the IP address of iMeter 7A. Click  to set the SNMP version and Port number in the SNMP Protocol Preferences dialog box.

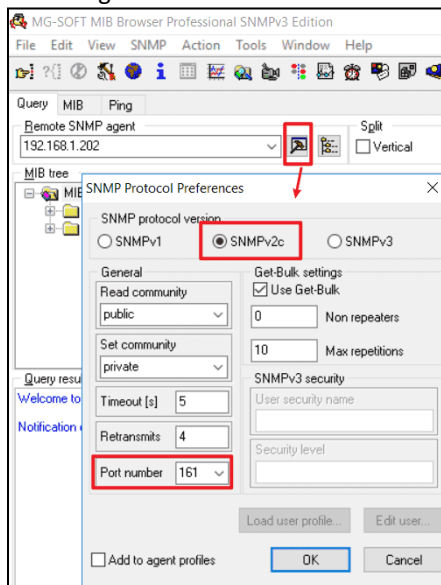

Figure 4-53 Set IP & SNMP Protocol Preferences

- In the **MIB Tree** panel, expand the MIB Tree and select the iMeter7A node to connect it by right-clicking it and choosing **Contact** from the pop-up context menu.

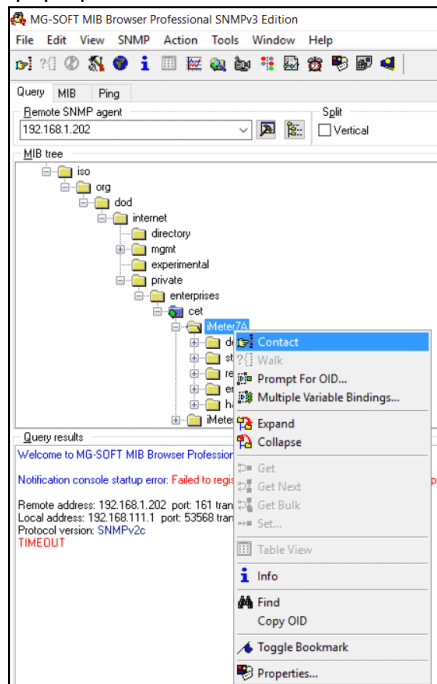

Figure 4-54 Connect the iMeter 7A via SNMP

- The user can query the Real-time measurements by Walk / Get command. For more instructions on MIB Browser, please refer to the [User Manual of MIB Browser](#).

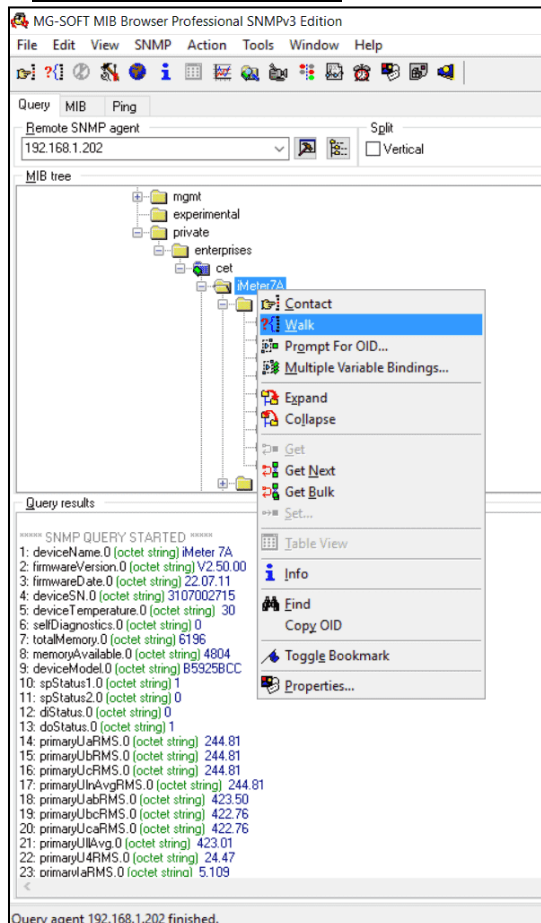

Figure 4-55 Query Measurements

4.13 On-board FTPS Server

File Transfer Protocol Secure (FTPS) is used to download COMTRADE files and other logged measurement data, such as the EN 50160 report, IEEE Std 519 report and the 2kHz to 150kHz Supraharmonic C.E. daily report, from the meter using an FTPS client software, such as FileZilla.

The iMeter 7A can support 5 FTPS connection simultaneously. And the FTPS timeout period is 5 minutes. Please note that the file structure of the FTPS files on the iMeter 7A is not permitted to change.

4.13.1 Access the FTPS Server

The following section illustrates the steps for accessing the iMeter 7A’s FTPS Server via FileZilla.

- 1) Configure the FTPS settings at **Setup -> Comm. -> Advanced** on the Web Server of the iMeter 7A.

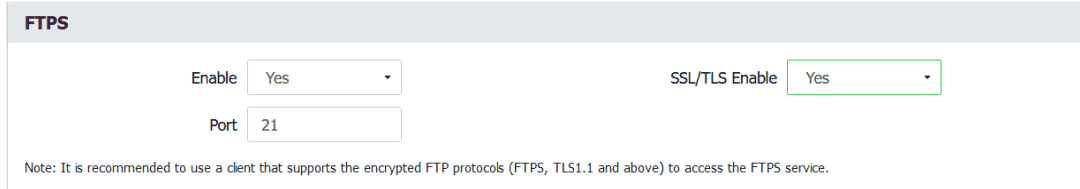

Figure 4-56 FTPS Settings on Web

- 2) Connect to the FTPS Server.
 - a. Enter the IP address, Username, Password and Port information for verification. Please note the Username/Password for FTPS and Web servers are identical. Click on the **Quickconnect** button.



Figure 4-57 FileZilla Connection

- b. Please tick on the selection box for **Always trust this certificate in future sessions** as shown in the following pop window and click on **OK**.

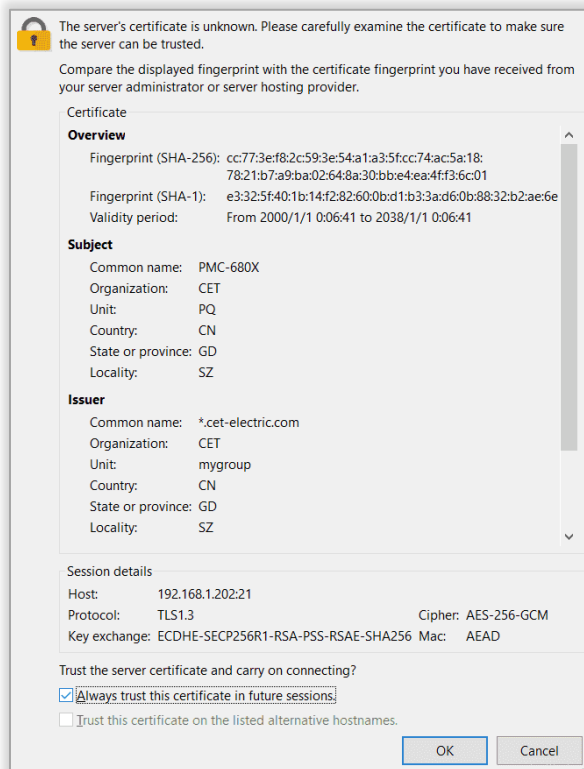

Figure 4-58 Trust Certificate

- 3) If the FTPS Server is connected successfully, the iMeter 7A’s FTPS site is displayed as shown in the following screenshot.



Figure 4-59 iMeter 7A’s FTPS Server

4.13.2 Quick Overview for FTPS Files

The following section provides a quick overview of the disturbRecord, faultRecord, rmsRecord in the **/comtrade** folder as well as the EN 50160 report, the IEEE Std 519 report and the 2kHz to 150kHz Supraharmonic C.E. daily report. Please copy the required files to your local computer before opening them with the appropriate application.

4.13.2.1 COMTRADE Files

COMTRADE (IEEE Standard Common Format for Transient Data Exchange) is a file format for storing oscillography and status data related for transient power system disturbance.

Three folders, **/disturbRecord**, **/rmsRecord** and **/waveRecord**, are discussed here under the **/comtrade** folder. In each folder, a set of COMTRADE files for a given event consists of two to four files with the same filename but different extensions, *.HDR (optional), *.CFG, *.DAT and *.INF (optional).

- HDR (Header) – contains general information about the event. It is written in ASCII format and its contents do not need to be stored in any particular order.
- CFG (Configuration) – a text file in ASCII or binary format. It contains only numbers and corresponds to samples taken of analog and digital channels, channel names, units, conversion factors, electrical system frequency, sampling frequency, sampling rates, date and time, and the format in which the data file was recorded.
- DAT (Data) – a text file in ASCII or binary format. It contains only numbers and corresponds to samples taken of analog and digital quantities. Its correct interpretation depends on the information contained in the configuration file. In the configuration file are specified means to translate these values accordingly to real quantities, such as volts and amperes.
- INF (Information) – a text file in ASCII or UTF-8 format. It contains extra information beyond the minimum required for the application of the dataset.

/disturbRecord saves the disturbance waveform recordings.

Filename	Filesize	Filetype	Last modified
disturbRecord-001-20220719_165945_681.dat	614,400	DAT File	2022/7/19 16:59:46
disturbRecord-001-20220719_165945_681.hdr	294	HDR File	2022/7/19 16:59:46
disturbRecord-001-20220719_165945_681.inf	115	Setup Inf...	2022/7/19 16:59:46
disturbRecord-002-20220719_165950_901.cfg	764	Configur...	2022/7/19 16:59:51
disturbRecord-002-20220719_165950_901.dat	614,400	DAT File	2022/7/19 16:59:51
disturbRecord-002-20220719_165950_901.hdr	294	HDR File	2022/7/19 16:59:51
disturbRecord-002-20220719_165950_901.inf	112	Setup Inf...	2022/7/19 16:59:51
disturbRecord-003-20220719_165956_811.cfg	764	Configur...	2022/7/19 16:59:57

Figure 4-60 disturbRecord Files

/faultRecord saves the waveform recordings including the scheduled waveform recording with fixed sampling rate configuration.

Filename	Filesize	Filetype	Last modified
waveRecord-001-20220719_170011_161.dat	1,228,800	DAT File	2022/7/19 17:00:13
waveRecord-001-20220719_170011_161.hdr	308	HDR File	2022/7/19 17:00:13
waveRecord-001-20220719_170011_161.inf	115	Setup Inf...	2022/7/19 17:00:13
waveRecord-002-20220719_170028_173.cfg	768	Configur...	2022/7/19 17:00:30
waveRecord-002-20220719_170028_173.dat	1,228,800	DAT File	2022/7/19 17:00:30
waveRecord-002-20220719_170028_173.hdr	314	HDR File	2022/7/19 17:00:30
waveRecord-002-20220719_170028_173.inf	115	Setup Inf...	2022/7/19 17:00:30

Figure 4-61 faultRecord Files

/rmsRecord saves the RMS recordings.

Filename	Filesize	Filetype	Last modified
rmsRecord-001-20220719_165945_681.dat	216,000	DAT File	2022/7/19 17:00:54
rmsRecord-002-20220720_104231_064.cfg	1,005	Configur...	2022/7/20 10:43:40
rmsRecord-002-20220720_104231_064.dat	216,000	DAT File	2022/7/20 10:43:40
rmsRecord-003-20220722_094501_025.cfg	1,005	Configur...	2022/7/22 9:46:10
rmsRecord-003-20220722_094501_025.dat	216,000	DAT File	2022/7/22 9:46:10

Figure 4-62 rmsRecord Files

4.13.2.2 EN 50160 Report

/en50160/report saves the latest 53 EN 50160 reports in .xls format. The downloaded .xls spreadsheets can be open in Excel.

Filename	Filesize	Filetype	Last modified
..			
en50160Report_0.xls	66,168	Microsof...	2021/12/26 0:00:06
en50160Report_1.xls	66,165	Microsof...	2022/1/9 0:00:06
en50160Report_10.xls	66,181	Microsof...	2022/3/21 8:20:04
en50160Report_11.xls	66,181	Microsof...	2022/3/27 0:00:05
en50160Report_12.xls	66,181	Microsof...	2022/4/3 0:00:05
en50160Report_13.xls	66,181	Microsof...	2022/4/10 0:00:06

Figure 4-63 EN 50160 Report

4.13.2.3 IEEE Std 519 Report

/ieee519/report saves the latest 365 daily reports and 53 weekly reports in a chronological order. The downloaded report in .xls format can be open in Excel.

Filename	Filesize	Filetype	Last modified
IEEE519Report_Day_9.xls	131,089	Microsof...	2023/1/9 0:00:05
IEEE519Report_Day_10.xls	131,089	Microsof...	2023/1/10 0:00:05
IEEE519Report_Day_11.xls	131,089	Microsof...	2023/1/11 0:00:05
IEEE519Report_Day_12.xls	131,089	Microsof...	2023/1/12 0:00:05
IEEE519Report_Day_13.xls	131,089	Microsof...	2023/1/13 0:00:05
IEEE519Report_Day_14.xls	131,089	Microsof...	2023/1/14 0:00:05
IEEE519Report_Day_15.xls	131,089	Microsof...	2023/1/15 0:00:05
IEEE519Report_Week_7.xls	196,465	Microsof...	2023/1/15 0:00:06

Figure 4-64 IEEE Std 519 Report

4.13.2.4 2kHz – 150kHz Supraharmonic C.E. Daily Report

/shr/ saves 4 files in .gz format for the Daily Amplitudes reports of Max./Min./Average/CP95 values in 2kHz - 150kHz every day. The .csv spreadsheets can be open in Excel after downloading and then decompressing the .gz files.

Filename	Filesize	Filetype	Last modified
CE_2KHz-150KHz_20230110_max.csv.gz	40,537	WinRAR ...	2023/1/11 0:00:06
CE_2KHz-150KHz_20230110_min.csv.gz	40,537	WinRAR ...	2023/1/11 0:00:12
CE_2KHz-150KHz_20230110_avg.csv.gz	40,537	WinRAR ...	2023/1/11 0:00:17
CE_2KHz-150KHz_20230110_CP95.csv.gz	40,537	WinRAR ...	2023/1/11 0:00:23
CE_2KHz-150KHz_20230111_max.csv.gz	40,537	WinRAR ...	2023/1/12 0:00:06
CE_2KHz-150KHz_20230111_min.csv.gz	40,537	WinRAR ...	2023/1/12 0:00:12
CE_2KHz-150KHz_20230111_avg.csv.gz	40,537	WinRAR ...	2023/1/12 0:00:17
CE_2KHz-150KHz_20230111_CP95.csv.gz	40,537	WinRAR ...	2023/1/12 0:00:23

Figure 4-65 2kHz – 150kHz Supraharmonic C.E. Daily Report

4.14 IPsec VPN

The iMeter 7A supports the implementation of the Internet Key Exchange (IKE) protocols which is required for Internet Protocol Security (IPsec) to protect data traffic between network peers. IPsec Tunnel is usually built to communicate hosts privately in two or more remote LANs via Internet as if the hosts are all in the same LAN. For more details about IPsec VPN, please refer to [Wikipedia](#).

Terms Glossary

IPsec – Internet Protocol Security is a series of open network security protocols and services provided on an IP network.

Security Protocol	ESP			AH		
Encryption	DES	3DES	AES			
Authentication	MD5	SHA1	SHA2	MD5	SHA1	SHA2
Key Exchange	IKE (ISAKMP, DH)					

Figure 4-66 IPsec Framework

IPsec protects IP packets using two security protocols: Authentication Header (AH) and Encapsulating Security Payload (ESP).

- AH provides data origin authentication, data integrity check and anti-replay.
- ESP provides encryption, data origin authentication, data integrity check and anti-replay.

SA – Security Association. A security association needs to be established between IPsec peers (two IPsec endpoints) before IPsec can implement secure data transmission. An SA defines a set of parameters for data transmission between two IPsec peers, including the security protocols, characteristics of data flows to be protected, data encryption mode, encryption algorithms, authentication algorithms, Key Exchange, IKE and SA lifetime.

Common encryption algorithms include Data Encryption Standard (DES), Tripple Data Encryption Standard (3DES), Advanced Encryption Standard (AES).

Common authentication algorithms include MD5, SHA1 and SHA2.

Encapsulation Mode – Encapsulation is a process of adding AH or ESP fields to original IP packets for packet authentication and encryption. This process is implemented in either transport or tunnel mode. The tunnel mode is more secure because original IP packets are completely authenticated and encrypted. This mode hides the IP address, protocol type and port number in an original IP packet. But the tunnel mode generates an additional IP header, occupying more bandwidth than the transport mode.

IKE – Internet Key Exchange is a UDP-based application layer protocol built on the Internet Security Association and Key Management Protocol (ISAKMP) framework. It implements automatic key negotiation and IPsec SA setup, to simplify IPsec use and management, facilitate IPsec configuration and maintenance.

IKE Authentication Mode – Two peers authenticate the identity (IP address or name) of each other, using pre-shared key (PSK) authentication or RSA signature authentication.

IKE Version – IKE has two versions: V1 and V2. V2 has the following advantages over V1.

- Simplifies SA negotiation and improves negotiation efficiency.
- Fixes many cryptographic vulnerabilities, enhancing security.

IKEv1 Two Phases – IKEv1 goes through two phases to establish SA (security association). In phase 1, two peers negotiate and establish a secure tunnel, which is an IKE SA. In phase 2, the peers establish a pair of IPsec SAs for secure data transmission through the secure tunnel established in phase 1.

IKEv1 Exchange Mode – IKEv1 phase 1 can use either main mode or aggressive mode. The main mode requires three exchanges between the peers, totally six ISAKMP messages. The aggressive mode requires only two exchanges, totally three messages.

The VPN parameters are programmable via Web server or through communications. The following table illustrates the detailed definition and setup range of the iMeter 7A VPN parameters.

Parameters	Definition	Options/Default*
Basic		
Operating Mode	Specify the working mode of the iMeter 7A in the virtual network	Disabled*, Terminal, Gateway
Start Mode	Specify the starting mode of IKE negotiation. Auto – initiate the IKE negotiation as an initiator. Manual – respond to the IKE negotiation as a responder. Flow Activated – initiate the IKE negotiation when IPsec traffic is received.	Auto, Manual*, Flow Activated
Local Subnet Address	Specify the local network address to which the policy is applied.	xxx.xxx.xxx.xxx, null*
Local Subnet Mask	Specify the local network subnet mask	xxx.xxx.xxx.xxx, null*
Peer Address	Specify the remote peer address to which the policy is applied.	xxx.xxx.xxx.xxx, null*
Exchange Mode	Specify the main mode or aggressive mode for IKE phase 1.	Main, Aggressive*
Peer Subnet Address	Specify the remote network address to which the policy is applied.	xxx.xxx.xxx.xxx, null*
Peer Subnet Mask	Specify the remote network subnet mask	xxx.xxx.xxx.xxx, null*
IKE Parameters		
Protocol Version	Specify the IKE protocol version.	IKE, IKEv1, IKEv2
Local Identity Mode	Specify the Local Identity Mode for IKE negotiation. IP Address - use an IP address as the ID for IKE negotiation. FQDN (fully qualified domain name) – use a DNS as the ID for IKE negotiation, e.g., iMeter 7A.example.com User FQDN – use an email address as the ID for IKE negotiation, e.g., iMeter 7A@example.com	IP*, User FQDN, FQDN
Authentication Mode	Specify the IKE authentication mode is Preshared Key or Digital Certificate.	Preshared Key*, Digital Certificate
Lifetime	Specify the ISAKMP SA Lifetime in IKE negotiation.	60-86400 (s), 28800*
Proposal	Select the proposal for IKE negotiation phase 1 to specify the encryption algorithms, authentication algorithms and DH group.	See Note 1
Local Identity	Enter the IP or the name as the ID for the IKE negotiation.	Null*
Peer Identity	Enter the IP or the name as the ID for the IKE negotiation.	Null*
Key	Enter the Preshared key for peer’s authentication.	Null*
IPsec Parameters		
Protocol	Specify the protocol used for IPsec encapsulation.	ESP*, AH
Proposal	Select the proposal for IKE negotiation phase 2 to specify the encryption algorithms, authentication algorithms and DH group.	See Note 1
Lifetime	Specify the IPsec SA lifetime in IKE negotiation.	60-86400 (s), 28800*
Keep-Alive Parameters		
PING Interval	Specify the interval to send the Echo request to the PING target address	0-86400 (s), 0*

PING Target Address	Enter the target address for PING diagnostic tool	Null*
Reconnection Interval	Specify the time interval for IPsec VPN reconnection	0-86400 (s), 0*

Table 4-43 VPN Setup Parameters

Note:

1. The iMeter 7A supports the following proposals for Encryption Algorithms, Authentication Algorithms and DH Group.

ID	Proposal	ID	Proposal	ID	Proposal
0	3DES_MD5_DH1	6	AES_MD5_DH1	12	DES_MD5_DH1
1	3DES_MD5_DH2	7	AES_MD5_DH2	13	DES_MD5_DH2
2	3DES_MD5_DH5	8	AES_MD5_DH5	14	DES_MD5_DH5
3	3DES_SHA1_DH1	9	AES_SHA1_DH1	15	DES_SHA1_DH1
4	3DES_SHA1_DH2	10	AES_SHA1_DH2	16	DES_SHA1_DH2
5	3DES_SHA1_DH5	11	AES_SHA1_DH5	17	DES_SHA1_DH5

Table 4-44 Proposal Options

4.15 Cloud

The iMeter 7A supports the Cloud feature which allows the user to access the measurements remotely and securely. The user can view the Cloud connection status via the Front Panel, Web Interface or through communications.

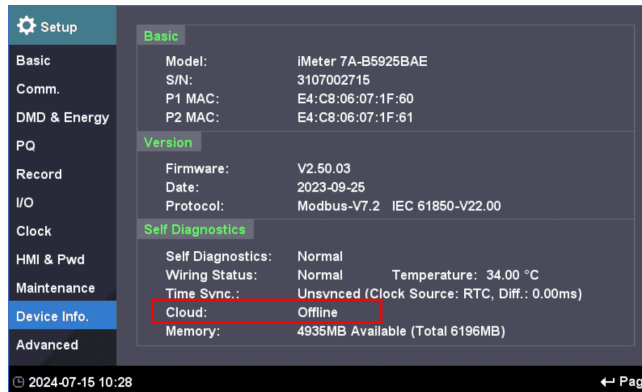

Figure 4-67 Cloud connection status

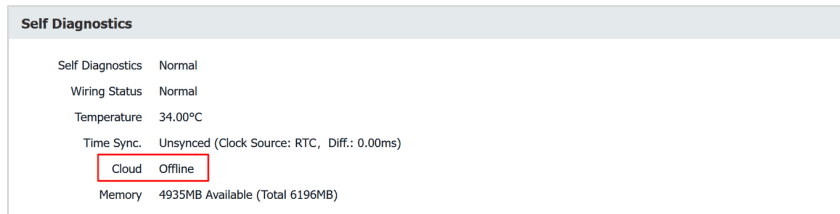

Figure 4-68 Cloud Connection Status

The following table illustrates the basic and upload parameters for Cloud feature.

Parameters	Definition	Options/Default*
Basic Settings		
Enable	Enable or Disable Cloud feature.	0=No*, 1=Yes
Encryption	Specify whether the data uploaded to the cloud is encrypted.	0=No, 1=Yes*
File Upload Port	Specify the port ID used for log file upload service.	1 to 65535, 30080*
Upload Port	Specify the port ID used for data upload service.	1 to 65535, 38084*
Server Address	Specify the Cloud Server IP address.	0.0.0.0*
Upload Settings		
Upload Interval	Specify the interval between uploading the data to the Cloud.	3 to 7200 (s), 10*
Real Time	Select the type of Real Time measurement uploaded to the Cloud.	See Table 5-86, 0*
Harmonics	Select the type of Harmonics measurement uploaded to the Cloud.	See Table 5-86, 0*
Interharmonics	Select the type of Interharmonics measurement uploaded to the Cloud.	See Table 5-86, 0*
2k-150kHz C.E.	Select the type of 2kHz-150kHz C.E. measurement uploaded to the Cloud.	See Table 5-86, 0*
Log	Select the type of Log uploaded to the Cloud.	See Table 5-87, 0*

Table 4-45 Cloud Setup Parameters

Chapter 5 Modbus Map

This chapter provides a complete description of the Modbus register map (**Protocol Version 7.4**) for the iMeter 7A to facilitate the development of 3rd party Modbus RTU communications driver for accessing the information on the meter.

The iMeter 7A supports the following Modbus functions:

- 1) Read Holding Registers (Function Code 0x03)
- 2) Force Single Coil (Function Code 0x05)
- 3) Preset Multiple Registers (Function Code 0x10)

For a complete Modbus Protocol Specification, please visit <http://www.modbus.org>.

5.1 Function Code and Data Format

5.1.1 03 (0x03) Read Holding Registers

The following table illustrates the Data Format for Read Holding Registers Request/Response packet.

Request Packet (Master Station to iMeter 7A)		Response Packet (iMeter 7A to Master Station)	
Field Name	Bytes	Field Name	Bytes
Slave Address	1 Byte	Slave Address	1 Byte
Function Code (0x03)	1 Byte	Function Code (0x03)	1 Byte
Starting Address Hi	1 Byte	Byte Count N	1 Byte
Starting Address Lo	1 Byte	Data 1 Hi	1 Byte
No. of Registers Hi	1 Byte	Data 1 Lo	1 Byte
No. of Registers Lo	1 Byte	...	
Error Check (CRC)	2 Bytes	Data N/2 Hi	1 Byte
		Data N/2 Lo	1 Byte
		Error Check (CRC)	2 Bytes

Table 5-1 Data Format for 0x03 Request/Response Packet

5.1.2 05 (0x05) Force Single Coil

The following table illustrates the Data Format for Force Single Coil Arm/Execute Request/Response packet.

Arm Request/Response

Request Packet (Master Station to iMeter 7A)		Response Packet (iMeter 7A to Master Station)	
Field Name	Bytes	Field Name	Bytes
Slave Address	1 Byte	Slave Address	1 Byte
Function Code (0x05)	1 Byte	Function Code (0x05)	1 Byte
Output Address Hi	1 Byte	Output Address Hi	1 Byte
Output Address Lo	1 Byte	Output Address Lo	1 Byte
Output Value Hi (0xFF)	1 Byte	Output Value Hi (0xFF)	1 Byte
Output Value Lo (0x00)	1 Byte	Output Value Lo (0x00)	1 Byte
Error Check (CRC)	2 Bytes	Error Check (CRC)	2 Bytes

Table 5-2 Data Format for 0x05 Arm Request/Response Packet

Execute Request/Response

Request Packet (Master Station to iMeter 7A)		Response Packet (iMeter 7A to Master Station)	
Field Name	Bytes	Field Name	Bytes
Slave Address	1 Byte	Slave Address	1 Byte
Function Code (0x05)	1 Byte	Function Code (0x05)	1 Byte
Output Address Hi	1 Byte	Output Address Hi	1 Byte
Output Address Lo	1 Byte	Output Address Lo	1 Byte
Output Value Hi (0xFF)	1 Byte	Output Value Hi (0xFF)	1 Byte
Output Value Lo (0x00)	1 Byte	Output Value Lo (0x00)	1 Byte
Error Check (CRC)	2 Bytes	Error Check (CRC)	2 Bytes

Table 5-3 Data Format for 0x05 Execute Request/Response Packet

The iMeter 7A adopts the ARM before EXECUTE operation for the remote control of its Digital Outputs if this function is enabled through the **Arm Before Execute Enable** Setup register (40301), which is enabled by default. Before executing an OPEN or CLOSE command on a Relay Output, it must be “Armed” first. This is achieved by writing the value 0xFF00 to the appropriate register to “Arm” a particular DO operation. The DO will be “Disarmed” automatically if an “Execute” command is not received within 15 seconds after it has been “Armed”. If an “Execute” command is received without first having received

an “Arm” command, the meter ignores the “Execute” command and returns the 0x04 exception code.

5.1.3 16 (0x10) Write Multiple Registers

The following table illustrates the Data Format for Write Multiple Registers request/response packet.

Request Packet (Master Station to iMeter 7A)		Response Packet (iMeter 7A to Master Station)	
Field Name	Bytes	Field Name	Bytes
Slave Address	1 Byte	Slave Address	1 Byte
Function Code (0x10)	1 Byte	Function Code (0x10)	1 Byte
Starting Address Hi	1 Byte	Starting Address Hi	1 Byte
Starting Address Lo	1 Byte	Starting Address Lo	1 Byte
No. of Registers Hi	1 Byte	No. of Registers Hi	1 Byte
No. of Registers Lo	1 Byte	No. of Registers Lo	1 Byte
Byte Count N	1 Byte	Error Check (CRC)	2 Bytes
Data 1 Hi	1 Byte		
Data 1 Lo	1 Byte		
...			
Data N/2 Hi	1 Byte		
Data N/2 Lo	1 Byte		
Error Check (CRC)	2 Bytes		

Table 5-4 Data Format for 0x10 Request/Response Packet

5.2 Register Format

The following table provides a description of the different data formats used for the Modbus registers.

Format	Description
UINT16/INT16	Unsigned/signed 16-bit integer
UINT32/INT32	Unsigned/signed 32-bit integer
INT64	Signed 64-bit integer
FLOAT	IEEE 754 32-bit floating point number (single precision)
BITMAP	16-bit or 32-bit binary register where each bit represents a specific quantity
CHAR	16-bit binary register which represents a single Unicode character.

Table 5-5 Register Format

5.3 Data Encoding

The iMeter 7A uses the Big-Endian byte ordering system. This means that when a numeric quantity larger than a single byte is transmitted, the most significant byte is sent first. For example, value of Register 0000 is “0x44 71 13 88”, the first byte sent is “0x44”, then “0x71”, “0x13” and finally “0x88”.

5.4 Basic Measurement

Register	Property	Description	Format	Unit
0000	RO	Ua ¹	FLOAT	V
0002	RO	Ub ¹	FLOAT	V
0004	RO	Uc ¹	FLOAT	V
0006	RO	UIn Avg. ¹	FLOAT	V
0008	RO	Uab	FLOAT	V
0010	RO	Ubc	FLOAT	V
0012	RO	Uca	FLOAT	V
0014	RO	UII Avg.	FLOAT	V
0016	RO	Ia	FLOAT	A
0018	RO	Ib	FLOAT	A
0020	RO	Ic	FLOAT	A
0022	RO	I Avg.	FLOAT	A
0024	RO	Pa (kW) ¹	FLOAT	W
0026	RO	Pb (kW) ¹	FLOAT	W
0028	RO	Pc (kW) ¹	FLOAT	W
0030	RO	P (kW) Total	FLOAT	W
0032	RO	Qa (kvar) ¹	FLOAT	var
0034	RO	Qb (kvar) ¹	FLOAT	var
0036	RO	Qc (kvar) ¹	FLOAT	var
0038	RO	Q (kvar) Total	FLOAT	var

CET Electric Technology

0040	RO	Sa (kVAa) ¹	FLOAT	VA
0042	RO	Sb (kVAb) ¹	FLOAT	VA
0044	RO	Sc (kVAc) ¹	FLOAT	VA
0046	RO	S (kVA) Total	FLOAT	VA
0048	RO	PFa ¹	FLOAT	--
0050	RO	PFb ¹	FLOAT	--
0052	RO	PFc ¹	FLOAT	--
0054	RO	PF Total	FLOAT	--
0056	RO	Frequency	FLOAT	Hz
0058	RO	U4	FLOAT	V
0060	RO	I4	FLOAT	A
0062	RO	Ung	FLOAT	V
0064	RO	Real-time Data Timestamp - Second (UNIX Time) ²	UINT32	s
0066	RO	Real-time Data Timestamp - Millisecond (UNIX Time) ²	UINT32	ms
0068	RO	Frequency Timestamp - Second (UNIX Time) ²	UINT32	s
0070	RO	Frequency Timestamp - Millisecond (UNIX Time) ²	UINT32	ms
0072	RO	Pst Timestamp - Second (UNIX Time) ²	UINT32	s
0074	RO	Pst Timestamp - Millisecond (UNIX Time) ²	UINT32	ms
0076	RO	Plt Timestamp - Second (UNIX Time) ²	UINT32	s
0078	RO	Plt Timestamp - Millisecond (UNIX Time) ²	UINT32	ms
0080	RO	Flagging Status of Real-time Voltage Data ²	BITMAP	
0081	RO	Flagging Status of Real-time Current Data ²	BITMAP	
0082	RO	Flagging Status of Frequency Measurements ²	BITMAP	
0083	RO	Flagging Status of Pst Measurements ²	BITMAP	
0084	RO	Flagging Status of Plt Measurements ²	BITMAP	
0085~0092	--	Reserved	--	
0093~0094	RO	Setpoint Status 1 ⁴	BITMAP	
0095~0096	RO	Setpoint Status 2 ⁴	BITMAP	
0097~0113	--	Reserved	--	
0115	RO	Dips Counter	UINT32	
0117	RO	Swells Counter	UINT32	
0119	RO	Interruption Counter	UINT32	
0121	RO	Transient Counter	UINT32	
0123	RO	RVC (Rapid Voltage Change) Counter	UINT32	
0125	RO	Inrush Current Counter	UINT32	
0127	--	Reserved	--	
0129	RO	Mains Signalling Voltage #1 Event Counter	UINT32	
0131	RO	Mains Signalling Voltage #2 Event Counter	UINT32	
0133	RO	Mains Signalling Voltage #3 Event Counter	UINT32	
0135	RO	Total PQ Counter	UINT32	
0137	RO	Device Log Pointer ⁵	UINT32	
0139	RO	SOE Log Pointer ⁵	UINT32	
0141	RO	WFR Log Pointer ⁵	UINT32	
0143	RO	RMSR Log Pointer ⁵	UINT32	
0145	RO	DWR Log Pointer ⁵	UINT32	
0147~0157	--	Reserved	--	
0159	RO	SDR Log #1 Pointer ⁵	UINT32	
0161	RO	SDR Log #2 Pointer ⁵	UINT32	
0163	RO	SDR Log #3 Pointer ⁵	UINT32	
0165	RO	SDR Log #4 Pointer ⁵	UINT32	
0167	RO	SDR Log #5 Pointer ⁵	UINT32	
0169	RO	SDR Log #6 Pointer ⁵	UINT32	
0171	RO	SDR Log #7 Pointer ⁵	UINT32	
0173	RO	SDR Log #8 Pointer ⁵	UINT32	
0175~0205	--	Reserved	--	
0207	RO	DR Log #1 Pointer ⁵	UINT32	
0209	RO	DR Log #2 Pointer ⁵	UINT32	
0211	RO	DR Log #3 Pointer ⁵	UINT32	
0213	RO	DR Log #4 Pointer ⁵	UINT32	
0215	RO	DR Log #5 Pointer ⁵	UINT32	

0217	RO	DR Log #6 Pointer ⁵	UINT32	
0219	RO	DR Log #7 Pointer ⁵	UINT32	
0221	RO	DR Log #8 Pointer ⁵	UINT32	
0223~0237	--	Reserved	--	
0239	RO	Pst Log Pointer ⁵	UINT32	
0241	RO	Plt Log Pointer ⁵	UINT32	
0243	--	Reserved	--	
0245	RO	3-phase Total IER Log Pointer ⁵	UINT32	
0247	RO	EN 50160 Report Pointer ⁵	UINT32	
0249	RO	Reserved	UINT32	
0251	RO	Historical TOU Log Pointer ⁵	UINT32	
0253	--	Reserved	--	
0255	RO	Device Running Hour	UINT32	x0.1 H
0257	RO	3-phase Total AER Log Pointer ⁵	UINT32	
0259	--	Reserved	--	
0261	RO	Conduct Emissions in the 2-150kHz Range Recorder Pointer ⁵	UINT32	
0263	RO	IR	FLOAT	A
0265	RO	IEEE Std 519-2022 Daily Report Log Pointer	UINT32	
0267	RO	IEEE Std 519-2022 Weekly Report Log Pointer	UINT32	
0269	RO	Per-phase AER Log Pointer	UINT32	
0271	RO	Per-phase IER Log Pointer	UINT32	
0273~0293	--	Reserved	--	
0294	RO	HS Frequency	FLOAT	Hz
0296	RO	dFreq.	FLOAT	Hz/s
0300	RO	A1 ⁶	FLOAT	
0302	RO	A2 ⁶	FLOAT	
0304~0306	--	Reserved	--	
0308	RO	DI Status ⁷	BITMAP	
0309	--	Reserved	--	
0310	RO	DO Status ⁸	BITMAP	
0311~0316	--	Reserved	--	
0318	RO	TC1 ⁶	FLOAT	°C
0320	RO	TC2 ⁶	FLOAT	°C
0322	RO	Cloud Connection Status	UINT16	

Table 5-6 Basic Measurement

Notes:

1. When the **Wiring Mode** is **3P3W**, the per phase Uln, P (kW), Q (kvar), S (kVA) and PF have no meaning, and their registers are reserved.
2. The Second register and the Millisecond register must be read in a single transaction.
3. The bit value of "1" for **Flagging Status of Real-time Current Data** register (0081) means the measurement is flagged due to overcurrent. The table below lists details of the **Flagging Status** registers (0080, 0082 to 0084).

Flagging Status

BIT	Description	BIT	Description
B0	Real-time Voltage Data (Register 0080)	B0	Dip
B1		B1	Swell
B2		B2	Interruption
B0	Frequency (Register 0082)	B0	Dip
B1		B1	Swell
B2		B2	Interruption

Table 5-7 Flagging Status

4. The BIT0 to BIT31 of Setpoint Status 1 (0093) and Setpoint Status 2 (0095) stand for the status of Setpoint 1 to Setpoint 64, respectively, with a bit value of "1" meaning active, while "0" meaning inactive.
5. The **Log Pointer** indicates its current logging position with a range of 0 and 0xFFFFFFFF, and it is incremented by one for every new log generated and will roll over to 0 if its current value is 0xFFFFFFFF. A value of 0 indicates that the recorder doesn't contain any logs. If a **Clear xxx Log** is performed from the Front Panel, Web Page or via communications, its corresponding **Log Pointer** will be reset to zero, which will be recorded into SOE Log and the SOE Log Pointer will be immediately incremented by one. When the Log Pointer is larger than the respective Log Depth, the latest logs are stored on a FIFO (if Record Mode = FIFO).

The following table lists the Log Depth for each Log Recorder:

Recorder	Depth	Recorder	Depth	Recorder	Depth	Recorder	Depth	Recorder	Depth
Device Log	1024	DWR	128	Plt	4380	DR	65535	SDR (1-8)	43200
SOE	1024	RMSR	128	IER	65535	EN 50160	53		
WFR	128	Pst	52560	AER	65535	Historical TOU	12		

Table 5-8 Log Depth

6. Valid only when the device is equipped with a corresponding option.
7. For the DI Status register, the bit values of B0 to B7 represent the states of DI1 to DI8, respectively, with “1” meaning Active (Closed) and “0” meaning Inactive (Open).
8. For the DO Status register, the bit value of B0 represents the Alarm state while the bit values of B1 to B4 represent the states of DO1 to DO4, respectively, with “1” meaning Operated (Closed) and “0” meaning Released (Open).

5.5 High-Speed Measurement

Register	Property	Description	Format	Unit
0350	RO	High-Speed Measurement Timestamp – Second (UNIX Time)		
0352	RO	High-Speed Measurement Timestamp – Millisecond (UNIX Time)		
0354	RO	Ua ¹	FLOAT	V
0356	RO	Ub ¹	FLOAT	V
0358	RO	Uc ¹	FLOAT	V
0360	RO	Uln Avg. ¹	FLOAT	V
0362	RO	Uab	FLOAT	V
0364	RO	Ubc	FLOAT	V
0366	RO	Uca	FLOAT	V
0368	RO	Ull Avg.	FLOAT	V
0370	RO	Ia	FLOAT	A
0372	RO	Ib	FLOAT	A
0374	RO	Ic	FLOAT	A
0376	RO	I Avg.	FLOAT	A
0378	RO	Pa (kWa) ¹	FLOAT	W
0380	RO	Pb (kWb) ¹	FLOAT	W
0382	RO	Pc (kWc) ¹	FLOAT	W
0384	RO	P (kW) Total	FLOAT	W
0386	RO	Qa (kvara) ¹	FLOAT	var
0388	RO	Qb (kvarb) ¹	FLOAT	var
0390	RO	Qc (kvarc) ¹	FLOAT	var
0392	RO	Q (kvar) Total	FLOAT	var
0394	RO	Sa (kVAa) ¹	FLOAT	VA
0396	RO	Sb (kVAb) ¹	FLOAT	VA
0398	RO	Sc (kVAc) ¹	FLOAT	VA
0400	RO	S (kVA) Total	FLOAT	VA
0402	RO	PFa ¹	FLOAT	--
0404	RO	PFb ¹	FLOAT	--
0406	RO	PFc ¹	FLOAT	--
0408	RO	PF Total	FLOAT	--
0410	RO	Frequency	FLOAT	Hz
0412	RO	U4	FLOAT	V
0414	RO	I4	FLOAT	A
0416	RO	dFreq.	FLOAT	Hz/s

Table 5-9 High-Speed Measurement

Note:

1) When the **Wiring Mode** is **3P3W**, the per phase Uln, P (kW), Q (kvar), S (kVA) and PF have no meaning, and their registers are reserved.

5.6 3-Phase Total Energy Measurement (INT64)

The Energy registers will roll over to zero automatically when the maximum value is reached, which depends on the **Energy Short Rollover’s** (Register 40758) setting:

- 0: maximum value of 100,000,000,000,000 (default)
- 1: maximum value of 1,000,000,000,000

Register	Property	Description	Format	Scale	Unit
0500	RW	∑kWh Imp.	INT64	1	wh
0504	RW	∑kWh Exp.	INT64	1	wh
0508	RW	∑kvarh Imp.	INT64	1	varh
0512	RW	∑kvarh Exp.	INT64	1	varh
0516	RW	∑kVAh	INT64	1	VAh
0520	RO	∑kWh Net	INT64	1	wh
0524	RO	∑kWh Total	INT64	1	wh
0528	RO	∑kvarh Net	INT64	1	varh
0532	RO	∑kvarh Total	INT64	1	varh

Table 5-10 3-phase Total Energy Measurement (INT64)

5.7 3-Phase Total Energy Measurement (INT32)

The Energy measurement should be calculated based on E1 & E2:

$$\begin{aligned} \sum kxh \text{ (Import/Export/Net/Total)} &= E1 \times 100 \text{ GWh} + E2 \times 0.1 \text{ kWh} \\ &= E1 \times 10^8 \text{ kWh} + E2 \times 0.1 \text{ kWh} \end{aligned}$$

The E1 and E2 registers have a maximum value of 100 and 1000,000,000, respectively, and will roll over to zero automatically when it is reached. The E1 register will be incremented by 1 when the E2 register rolls over. The calculated Total kXh (Import/Export/Net/Total) has a maximum value of 1×10^{11} kxh. The E1 and E2 registers must be written simultaneously.

Register	Property	Description	Format	Scale	Unit
0550	RW	\sum kWh Import E1	INT32	1	100 GWh
0552	RW	\sum kWh Import E2	INT32	0.1	kWh
0554	RW	\sum kWh Export E1	INT32	1	100 GWh
0556	RW	\sum kWh Export E2	INT32	0.1	kWh
0558	RW	\sum kvarh Import E1	INT32	1	100 Gvarh
0560	RW	\sum kvarh Import E2	INT32	0.1	kvarh
0562	RW	\sum kvarh Export E1	INT32	1	100 Gvarh
0564	RW	\sum kvarh Export E2	INT32	0.1	kvarh
0566	RW	\sum kVAh E1	INT32	1	100 GVAh
0568	RW	\sum kVAh E2	INT32	0.1	kVAh
0570	RO	\sum kWh Net E1	INT32	1	100 GWh
0572	RO	\sum kWh Net E2	INT32	0.1	kWh
0574	RO	\sum kWh E1	INT32	1	100 GWh
0576	RO	\sum kWh E2	INT32	0.1	kWh
0578	RO	\sum kvarh Net E1	INT32	1	100 Gvarh
0580	RO	\sum kvarh Net E2	INT32	0.1	kvarh
0582	RO	\sum kvarh Total E1	INT32	1	100 Gvarh
0584	RO	\sum kvarh Total E2	INT32	0.1	kvarh

Table 5-11 3-phase Total Energy Measurement (INT32)

5.8 Per-phase Energy Measurements (INT64)

The Energy registers will roll over to zero automatically when the maximum value is reached, which depends on the **Energy Short Rollover's** (Register 40758) setting:

- 0: maximum value of 100,000,000,000,000 (default)
- 1: maximum value of 1,000,000,000,000

Register	Property	Description	Format	Scale	Unit
7500	RW	Phase A kWh Import	INT64	1	wh
7504	RW	Phase A kWh Export	INT64	1	wh
7508	RO	Phase A kWh Net	INT64	1	wh
7512	RO	Phase A kWh Total	INT64	1	wh
7516	RW	Phase A kvarh Import	INT64	1	varh
7520	RW	Phase A kvarh Export	INT64	1	varh
7524	RW	Phase A kvarh Net	INT64	1	varh
7528	RW	Phase A kvarh Total	INT64	1	varh
7532	RW	Phase A kVAh Total	INT64	1	VAh
7536	RW	Phase B kWh Import	INT64	1	wh
7540	RW	Phase B kWh Export	INT64	1	wh
7544	RO	Phase B kWh Net	INT64	1	wh
7548	RO	Phase B kWh Total	INT64	1	wh
7552	RW	Phase B kvarh Import	INT64	1	varh
7556	RW	Phase B kvarh Export	INT64	1	varh
7560	RW	Phase B kvarh Net	INT64	1	varh
7564	RW	Phase B kvarh Total	INT64	1	varh
7568	RW	Phase B kVAh Total	INT64	1	VAh
7572	RW	Phase C kWh Import	INT64	1	wh
7576	RW	Phase C kWh Export	INT64	1	wh
7580	RO	Phase C kWh Net	INT64	1	wh
7584	RO	Phase C kWh Total	INT64	1	wh

7588	RW	Phase C kvarh Import	INT64	1	varh
7592	RW	Phase C kvarh Export	INT64	1	varh
7596	RW	Phase C kvarh Net	INT64	1	varh
7600	RW	Phase C kvarh Total	INT64	1	varh
7604	RW	Phase C kVAh Total	INT64	1	VAh

Table 5-12 Per-phase Energy Measurements

5.9 Per-phase Energy Measurements (INT32)

The Energy measurement should be calculated based on E1 & E2:

$$\begin{aligned} \sum kxh \text{ (Import/Export/Net/Total)} &= E1 \times 100 \text{ GWh} + E2 \times 0.1 \text{ kWh} \\ &= E1 \times 10^8 \text{ kWh} + E2 \times 0.1 \text{ kWh} \end{aligned}$$

The E1 and E2 registers have a maximum value of 100 and 1000,000,000, respectively, and will roll over to zero automatically when it is reached. The E1 register will be incremented by 1 when the E2 register rolls over. The calculated Total kXh (Import/Export/Net/Total) has a maximum value of 1×10^{11} kXh. The E1 and E2 registers must be written simultaneously.

Register	Property	Description	Format	Scale	Unit
7650	RW	Phase A kWh Import E1	INT32	1	100 GWh
7652	RW	Phase A kWh Import E2	INT32	0.1	kWh
7654	RW	Phase A kWh Export E1	INT32	1	100 GWh
7656	RW	Phase A kWh Export E2	INT32	0.1	kWh
7658	RO	Phase A kWh Net E1	INT32	1	100 GWh
7660	RO	Phase A kWh Net E2	INT32	0.1	kWh
7662	RO	Phase A kWh Total E1	INT32	1	100 GWh
7664	RO	Phase A kWh Total E2	INT32	0.1	kWh
7666	RW	Phase A kvarh Import E1	INT32	1	100 Gvarh
7668	RW	Phase A kvarh Import E2	INT32	0.1	kvarh
7670	RW	Phase A kvarh Export E1	INT32	1	100 Gvarh
7672	RW	Phase A kvarh Export E2	INT32	0.1	kvarh
7674	RO	Phase A kvarh Net E1	INT32	1	100 Gvarh
7676	RO	Phase A kvarh Net E2	INT32	0.1	kvarh
7678	RO	Phase A kvarh Total E1	INT32	1	100 Gvarh
7680	RO	Phase A kvarh Total E2	INT32	0.1	kvarh
7682	RW	Phase A kVAh Total E1	INT32	1	100 GVAh
7684	RW	Phase A kVAh Total E2	INT32	0.1	kVAh
7686	RW	Phase B kWh Import E1	INT32	1	100 GWh
7688	RW	Phase B kWh Import E2	INT32	0.1	kWh
7690	RW	Phase B kWh Export E1	INT32	1	100 GWh
7692	RW	Phase B kWh Export E2	INT32	0.1	kWh
7694	RO	Phase B kWh Net E1	INT32	1	100 GWh
7696	RO	Phase B kWh Net E2	INT32	0.1	kWh
7698	RO	Phase B kWh Total E1	INT32	1	100 GWh
7700	RO	Phase B kWh Total E2	INT32	0.1	kWh
7702	RW	Phase B kvarh Import E1	INT32	1	100 Gvarh
7704	RW	Phase B kvarh Import E2	INT32	0.1	kvarh
7706	RW	Phase B kvarh Export E1	INT32	1	100 Gvarh
7708	RW	Phase B kvarh Export E2	INT32	0.1	kvarh
7710	RO	Phase B kvarh Net E1	INT32	1	100 Gvarh
7712	RO	Phase B kvarh Net E2	INT32	0.1	kvarh
7714	RO	Phase B kvarh Total E1	INT32	1	100 Gvarh
7716	RO	Phase B kvarh Total E2	INT32	0.1	kvarh
7718	RW	Phase B kVAh Total E1	INT32	1	100 GVAh
7720	RW	Phase B kVAh Total E2	INT32	0.1	kVAh
7722	RW	Phase C kWh Import E1	INT32	1	100 GWh
7724	RW	Phase C kWh Import E2	INT32	0.1	kWh
7726	RW	Phase C kWh Export E1	INT32	1	100 GWh
7728	RW	Phase C kWh Export E2	INT32	0.1	kWh
7730	RO	Phase C kWh Net E1	INT32	1	100 GWh
7732	RO	Phase C kWh Net E2	INT32	0.1	kWh
7734	RO	Phase C kWh Total E1	INT32	1	100 GWh
7736	RO	Phase C kWh Total E2	INT32	0.1	kWh

7738	RW	Phase C kvarh Import E1	INT32	1	100 Gvarh
7740	RW	Phase C kvarh Import E2	INT32	0.1	kvarh
7742	RW	Phase C kvarh Export E1	INT32	1	100 Gvarh
7744	RW	Phase C kvarh Export E2	INT32	0.1	kvarh
7746	RO	Phase C kvarh Net E1	INT32	1	100 Gvarh
7748	RO	Phase C kvarh Net E2	INT32	0.1	kvarh
7750	RO	Phase C kvarh Total E1	INT32	1	100 Gvarh
7752	RO	Phase C kvarh Total E2	INT32	0.1	kvarh
7754	RW	Phase C kVAh Total E1	INT32	1	100 GVAh
7756	RW	Phase C kVAh Total E2	INT32	0.1	kVAh

Table 5-13 Per-phase Energy Measurements (INT32)

5.10 DI Pulse Counter

The DI Counters have a maximum value of 999,999,999 and will roll over to zero automatically when it is reached.

Register	Property	Description	Format	Range
0650	RW	DI1 Counter	INT32	0 to 999,999,999
0652	RW	DI2 Counter	INT32	
0654	RW	DI3 Counter	INT32	
0656	RW	DI4 Counter	INT32	
0658	RW	DI5 Counter	INT32	
0660	RW	DI6 Counter	INT32	
0662	RW	DI7 Counter	INT32	
0664	RW	DI8 Counter	INT32	

Table 5-14 DI Pulse Counter

5.11 PQ Measurement

Register	Property	Description	Format	Unit
0700	RO	Ua Deviation ¹	FLOAT	
0702	RO	Ub Deviation ¹	FLOAT	
0704	RO	Uc Deviation ¹	FLOAT	
0706	RO	Uab Deviation	FLOAT	
0708	RO	Ubc Deviation	FLOAT	
0710	RO	Uca Deviation	FLOAT	
0712	RO	Ua Over Deviation ¹	FLOAT	
0714	RO	Ub Over Deviation ¹	FLOAT	
0716	RO	Uc Over Deviation ¹	FLOAT	
0718	RO	Uab Over Deviation	FLOAT	
0720	RO	Ubc Over Deviation	FLOAT	
0722	RO	Uca Over Deviation	FLOAT	
0724	RO	Ua Under Deviation ¹	FLOAT	
0726	RO	Ub Under Deviation ¹	FLOAT	
0728	RO	Uc Under Deviation ¹	FLOAT	
0730	RO	Uab Under Deviation	FLOAT	
0732	RO	Ubc Under Deviation	FLOAT	
0734	RO	Uca Under Deviation	FLOAT	
0736	RO	Freq. Deviation	FLOAT	Hz
0738~0748	--	Reserved	--	
0750	RO	U0 Unbal.	FLOAT	
0752	RO	U2 Unbal.	FLOAT	
0754	RO	I0 Unbal.	FLOAT	
0756	RO	I2 Unbal.	FLOAT	
0758	RO	U0	FLOAT	V
0760	RO	U1	FLOAT	V
0762	RO	U2	FLOAT	V
0764	RO	I0	FLOAT	A
0766	RO	I1	FLOAT	A
0768	RO	I2	FLOAT	A
0770	RO	Ua/Uab Pst	FLOAT	
0772	RO	Ub/Ubc Pst	FLOAT	
0774	RO	Uc/Uca Pst	FLOAT	
0776	RO	Ua/Uab Plt	FLOAT	

CET Electric Technology

0778	RO	Ub/Ubc Plt	FLOAT	
0780	RO	Uc/Uca Plt	FLOAT	
0782	--	Reserved	--	
0784	RO	Ia TDD	FLOAT	
0786	RO	Ib TDD	FLOAT	
0788	RO	Ic TDD	FLOAT	
0790	RO	I4 TDD	FLOAT	
0792	--	Reserved	--	
0794	RO	Ia TDD Odd	FLOAT	
0796	RO	Ib TDD Odd	FLOAT	
0798	RO	Ic TDD Odd	FLOAT	
0800	RO	I4 TDD Odd	FLOAT	
0802	--	Reserved	--	
0804	RO	Ia TDD Even	FLOAT	
0806	RO	Ib TDD Even	FLOAT	
0808	RO	Ic TDD Even	FLOAT	
0810	RO	I4 TDD Even	FLOAT	
0812	--	Reserved	--	
0814	RO	Ia K-Factor	FLOAT	
0816	RO	Ib K-Factor	FLOAT	
0818	RO	Ic K-Factor	FLOAT	
0820	RO	I4 K-Factor	FLOAT	
0822	--	Reserved	--	
0824	RO	Ia Crest Factor	FLOAT	
0826	RO	Ib Crest Factor	FLOAT	
0828	RO	Ic Crest Factor	FLOAT	
0830	RO	I4 Crest Factor	FLOAT	
0832	--	Reserved	--	
0834	RO	Ua Crest Factor	FLOAT	
0836	RO	Ub Crest Factor	FLOAT	
0838	RO	Uc Crest Factor	FLOAT	
0840	RO	U4 Crest Factor	FLOAT	
0842	RO	Ua/Uab MSV #1	FLOAT	V
0844	RO	Ub/Ubc MSV #1	FLOAT	V
0846	RO	Uc/Uca MSV #1	FLOAT	V
0848	RO	Ua/Uab MSV #2	FLOAT	V
0850	RO	Ub/Ubc MSV #2	FLOAT	V
0852	RO	Uc/Uca MSV #2	FLOAT	V
0854	RO	Ua/Uab MSV #3	FLOAT	V
0856	RO	Ub/Ubc MSV #3	FLOAT	V
0858	RO	Uc/Uca MSV #3	FLOAT	V

Table 5-15 PQ Measurement

Note:

1) When the **Wiring Mode** is **3P3W**, the per phase Uln, P (kW), Q (kvar), S (kVA) and PF have no meaning, and their registers are reserved.

5.12 Harmonic & Interharmonic Measurement

5.12.1 Harmonic Distortion

Register	Property	Description	Format	Unit/Scale
1000	RO	Ua/Uab THD ¹	FLOAT	%/x100
1002	RO	Ub/Ubc THD ¹	FLOAT	%/x100
1004	RO	Uc/Uca THD ¹	FLOAT	%/x100
1006	RO	U4 THD	FLOAT	%/x100
1008	RO	Ia THD	FLOAT	%/x100
1010	RO	Ib THD	FLOAT	%/x100
1012	RO	Ic THD	FLOAT	%/x100
1014	RO	I4 THD	FLOAT	%/x100
1016	--	Reserved	--	
1018	RO	Ua/Uab TOHD ¹	FLOAT	%/x100
1020	RO	Ub/Ubc TOHD ¹	FLOAT	%/x100
1022	RO	Uc/Uca TOHD ¹	FLOAT	%/x100
1024	RO	U4 TOHD	FLOAT	%/x100
1026	RO	Ia TOHD	FLOAT	%/x100
1028	RO	Ib TOHD	FLOAT	%/x100
1030	RO	Ic TOHD	FLOAT	%/x100
1032	RO	I4 TOHD	FLOAT	%/x100
1034	--	Reserved	--	
1036	RO	Ua/Uab TEHD ¹	FLOAT	%/x100
1038	RO	Ub/Ubc TEHD ¹	FLOAT	%/x100
1040	RO	Uc/Uca TEHD ¹	FLOAT	%/x100
1042	RO	U4 TEHD	FLOAT	%/x100
1044	RO	Ia TEHD	FLOAT	%/x100
1046	RO	Ib TEHD	FLOAT	%/x100
1048	RO	Ic TEHD	FLOAT	%/x100
1050	RO	I4 TEHD	FLOAT	%/x100
1052	--	Reserved	--	
1054	RO	Ua/Uab DC Component ¹	FLOAT	%/x100
1056	RO	Ub/Ubc DC Component ¹	FLOAT	%/x100
1058	RO	Uc/Uca DC Component ¹	FLOAT	%/x100
1060	RO	U4 DC Component	FLOAT	%/x100
1062	RO	Ia DC Component	FLOAT	%/x100
1064	RO	Ib DC Component	FLOAT	%/x100
1066	RO	Ic DC Component	FLOAT	%/x100
1068	RO	I4 DC Component	FLOAT	%/x100
1070	--	Reserved	--	
1072	RO	Ua/Uab HD01 ¹	FLOAT	%/x100
1074	RO	Ub/Ubc HD01 ¹	FLOAT	%/x100
1076	RO	Uc/Uca HD01 ¹	FLOAT	%/x100
1078	RO	U4 HD01	FLOAT	%/x100
1080	RO	Ia HD01	FLOAT	%/x100
1082	RO	Ib HD01	FLOAT	%/x100
1084	RO	Ic HD01	FLOAT	%/x100
1086	RO	I4 HD01	FLOAT	%/x100
1088	--	Reserved	--	
...	%/x100
2188	RO	Ua/Uab HD63 ¹	FLOAT	%/x100
2190	RO	Ub/Ubc HD63 ¹	FLOAT	%/x100
2192	RO	Uc/Uca HD63 ¹	FLOAT	%/x100
2194	RO	U4 HD63	FLOAT	%/x100
2196	RO	Ia HD63	FLOAT	%/x100
2198	RO	Ib HD63	FLOAT	%/x100
2200	RO	Ic HD63	FLOAT	%/x100
2202	RO	I4 HD63	FLOAT	%/x100
2204	--	Reserved	--	

Table 5-16 Harmonic Distortion

Note:

- 1) When the Wiring Mode is 3P3W, the Ua/Ub/Uc THD, TOHD, TEHD and Individual Harmonics mean Uab/Ubc/Uca THD, TOHD, TEHD and Individual Harmonics.

5.12.2 Harmonic RMS Measurement

Register	Property	Description	Format	Unit
2300	RO	Ua/Uab TH RMS ¹	FLOAT	V
2302	RO	Ub/Ubc TH RMS ¹	FLOAT	V
2304	RO	Uc/Uca TH RMS ¹	FLOAT	V
2306	RO	U4 TH RMS	FLOAT	V
2308	RO	Ia TH RMS	FLOAT	A
2310	RO	Ib TH RMS	FLOAT	A
2312	RO	Ic TH RMS	FLOAT	A
2314	RO	I4 TH RMS	FLOAT	A
2316	--	Reserved	--	
2318	RO	Ua/Uab TOH RMS ¹	FLOAT	V
2320	RO	Ub/Ubc TOH RMS ¹	FLOAT	V
2322	RO	Uc/Uca TOH RMS ¹	FLOAT	V
2324	RO	U4 TOH RMS	FLOAT	V
2326	RO	Ia TOH RMS	FLOAT	A
2328	RO	Ib TOH RMS	FLOAT	A
2330	RO	Ic TOH RMS	FLOAT	A
2332	RO	I4 TOH RMS	FLOAT	A
2334	--	Reserved	--	
2336	RO	Ua/Uab TEH RMS ¹	FLOAT	V
2338	RO	Ub/Ubc TEH RMS ¹	FLOAT	V
2340	RO	Uc/Uca TEH RMS ¹	FLOAT	V
2342	RO	U4 TEH RMS	FLOAT	V
2344	RO	Ia TEH RMS	FLOAT	A
2346	RO	Ib TEH RMS	FLOAT	A
2348	RO	Ic TEH RMS	FLOAT	A
2350	RO	I4 TEH RMS	FLOAT	A
2352	--	Reserved	--	
2354	RO	Ua/Uab DC Component RMS ¹	FLOAT	V
2356	RO	Ub/Ubc DC Component RMS ¹	FLOAT	V
2358	RO	Uc/Uca DC Component RMS ¹	FLOAT	V
2360	RO	U4 DC Component RMS	FLOAT	V
2362	RO	Ia DC Component RMS	FLOAT	A
2364	RO	Ib DC Component RMS	FLOAT	A
2366	RO	Ic DC Component RMS	FLOAT	A
2368	RO	I4 DC Component RMS	FLOAT	A
2370	--	Reserved	--	
2372	RO	Ua/Uab H01 RMS ¹	FLOAT	V
2374	RO	Ub/Ubc H01 RMS ¹	FLOAT	V
2376	RO	Uc/Uca H01 RMS ¹	FLOAT	V
2378	RO	U4 H01 RMS	FLOAT	V
2380	RO	Ia H01 RMS	FLOAT	A
2382	RO	Ib H01 RMS	FLOAT	A
2384	RO	Ic H01 RMS	FLOAT	A
2386	RO	I4 H01 RMS	FLOAT	A
2388	--	Reserved	--	
...	RO
3488	RO	Ua/Uab H63 RMS ¹	FLOAT	V
3490	RO	Ub/Ubc H63 RMS ¹	FLOAT	V
3492	RO	Uc/Uca H63 RMS ¹	FLOAT	V
3494	RO	U4 H63 RMS	FLOAT	V
3496	RO	Ia H63 RMS	FLOAT	A
3498	RO	Ib H63 RMS	FLOAT	A
3500	RO	Ic H63 RMS	FLOAT	A
3502	RO	I4 H63 RMS	FLOAT	A
3504	--	Reserved	--	

Table 5-17 Harmonic RMS Measurement

Note:

- 1) When the Wiring Mode is 3P3W, the TH/TOH/TEH RMS and Individual Harmonic RMS for Ua/Ub/Uc mean the TH/TOH/TEH RMS and Individual Harmonic RMS for Uab/Ubc/Uca, respectively.

5.12.3 Individual Total Harmonic Power

Register	Property	Description	Format	Unit
27000	RO	ΣP Fund.	FLOAT	W
27002	RO	ΣQ Fund.	FLOAT	var
27004	RO	ΣS Fund.	FLOAT	VA
27006	RO	dPF	FLOAT	
27008	RO	ΣP H02	FLOAT	W
27010	RO	ΣQ H02	FLOAT	var
27012	RO	ΣS H02	FLOAT	VA
27014	RO	PF H02	FLOAT	
...		...		
27496	RO	ΣP H63	FLOAT	W
27498	RO	ΣQ H63	FLOAT	var
27500	RO	ΣS H63	FLOAT	VA
27502	RO	PF H63	FLOAT	

Table 5-18 Individual Total Harmonic Power

5.12.4 Harmonic Power

Register	Property	Description	Format	Unit
28000	RO	Pa TH ¹	FLOAT	W
28002	RO	Pb TH ¹	FLOAT	W
28004	RO	Pc TH ¹	FLOAT	W
28006	RO	P TH	FLOAT	W
28008	RO	Qa TH ¹	FLOAT	var
28010	RO	Qb TH ¹	FLOAT	var
28012	RO	Qc TH ¹	FLOAT	var
28014	RO	Q TH	FLOAT	var
28016	RO	Sa TH ¹	FLOAT	VA
28018	RO	Sb TH ¹	FLOAT	VA
28020	RO	Sc TH ¹	FLOAT	VA
28022	RO	S TH	FLOAT	VA
28024	RO	PFa TH ¹	FLOAT	
28026	RO	PFb TH ¹	FLOAT	
28028	RO	PFc TH ¹	FLOAT	
28030	RO	PF TH	FLOAT	
28032~28038	--	Reserved	--	
28040	RO	Pa H01 ¹	FLOAT	W
28042	RO	Pb H01 ¹	FLOAT	W
28044	RO	Pc H01 ¹	FLOAT	W
28046	RO	Qa H01 ¹	FLOAT	var
28048	RO	Qb H01 ¹	FLOAT	var
28050	RO	Qc H01 ¹	FLOAT	var
28052	RO	Sa H01 ¹	FLOAT	VA
28054	RO	Sb H01 ¹	FLOAT	VA
28056	RO	Sc H01 ¹	FLOAT	VA
28058	RO	PFa H01 ¹	FLOAT	
28060	RO	PFb H01 ¹	FLOAT	
28062	RO	PFc H01 ¹	FLOAT	
...	RO	...	FLOAT	
29528	RO	Pa H63 ¹	FLOAT	W
29530	RO	Pb H63 ¹	FLOAT	W
29532	RO	Pc H63 ¹	FLOAT	W
29534	RO	Qa H63 ¹	FLOAT	var
29536	RO	Qb H63 ¹	FLOAT	var
29538	RO	Qc H63 ¹	FLOAT	var
29540	RO	Sa H63 ¹	FLOAT	VA
29542	RO	Sb H63 ¹	FLOAT	VA
29544	RO	Sc H63 ¹	FLOAT	VA
29546	RO	PFa H63 ¹	FLOAT	
29548	RO	PFb H63 ¹	FLOAT	
29550	RO	PFc H63 ¹	FLOAT	

Table 5-19 Harmonic Power

Note:

- 1) When the Wiring Mode is 3P3W, the Total Harmonics and Individual Harmonics for Phase A/B/C P, Q, S and PF have no meaning and their registers are reserved.

5.12.5 Harmonic Angle

Register	Property	Description	Format	Unit
30018	RO	Ua/Uab H01 Angle ¹	FLOAT	°
30020	RO	Ub/Ubc H01 Angle ¹	FLOAT	
30022	RO	Uc/Uca H01 Angle ¹	FLOAT	
30024	RO	U4 H01 Angle	FLOAT	
30026	RO	Ia H01 Angle	FLOAT	
30028	RO	Ib H01 Angle	FLOAT	
30030	RO	Ic H01 Angle	FLOAT	
30032	RO	I4 H01 Angle	FLOAT	
30034	--	Reserved	--	
...	RO	...	FLOAT	
31134	RO	Ua/Uab H63 Angle ¹	FLOAT	
31136	RO	Ub/Ubc H63 Angle ¹	FLOAT	
31138	RO	Uc/Uca H63 Angle ¹	FLOAT	
31140	RO	U4 H63 Angle	FLOAT	
31142	RO	Ia H63 Angle	FLOAT	
31144	RO	Ib H63 Angle	FLOAT	
31146	RO	Ic H63 Angle	FLOAT	
31148	RO	I4 H63 Angle	FLOAT	
31150	--	Reserved	--	

Table 5-20 Harmonic Angle

Note:

1) When the Wiring Mode is 3P3W, the Phase A/B/C Voltage Individual Angles mean Phase AB/BC/CA Voltage Individual Angles, respectively.

5.12.6 Harmonic Energy (INT64)

The Energy registers will roll over to zero automatically when the maximum value is reached, which depends on the **Energy Short Rollover's** (Register 40758) setting:

- 0: maximum value of 100,000,000,000,000 (Default)
- 1: maximum value of 1,000,000,000,000

Register	Property	Description	Format	Unit
31500	RW	Total Harmonic kWh Import	INT64	wh
31504	RW	Total Harmonic kWh Export	INT64	wh
31508	RW	Total Harmonic kvarh Import	INT64	varh
31512	RW	Total Harmonic kvarh Export	INT64	varh
31516	RO	Total Harmonic kWh Net	INT64	wh
31520	RO	Total Harmonic kWh Total	INT64	wh
31524	RO	Total Harmonic kvarh Net	INT64	varh
31528	RO	Total Harmonic kvarh Total	INT64	varh
31532~31598	--	Reserved	--	
31600	RW	Fundamental kWh Import	INT64	wh
31604	RW	Fundamental kWh Export	INT64	wh
31608	RW	Fundamental kvarh Import	INT64	varh
31612	RW	Fundamental kvarh Export	INT64	varh
31616	RO	Fundamental kWh Net	INT64	wh
31620	RO	Fundamental kWh Total	INT64	wh
31624	RO	Fundamental kvarh Net	INT64	varh
31628	RO	Fundamental kvarh Total	INT64	varh
31632	RW	kWh Imp. H02	INT64	wh
31636	RW	kWh Exp. H02	INT64	wh
31640	RW	kvarh Imp. H02	INT64	varh
31644	RW	kvarh Exp. H02	INT64	varh
...	RW	...	INT64	
32608	RW	kWh Imp. H63	INT64	Wh
32612	RW	kWh Exp. H63	INT64	Wh
32616	RW	kvarh Imp. H63	INT64	varh
32620	RW	kvarh Exp. H63	INT64	varh

Table 5-21 Harmonic Energy (INT64)

5.12.7 Harmonic Energy (INT32)

The Energy measurement should be calculated based on E1 & E2:

$$\sum kxh \text{ (Import/Export/Net/Total)}$$

$$= E1 \times 100 \text{ GWh} + E2 \times 0.1 \text{ kWh}$$

$$= E1 \times 10^8 \text{ kWh} + E2 \times 0.1 \text{ kWh}$$

The E1 and E2 registers have a maximum value of 100 and 1000,000,000, respectively, and will roll over to zero automatically when it is reached. The E1 register will be incremented by 1 when the E2 register rolls over. The calculated Total kWh (Import/Export/Net/Total) has a maximum value of 1×10^{11} kWh. The E1 and E2 registers must be written simultaneously.

Register	Property	Description	Format	Scale	Unit
32800	RW	Total Harmonic kWh Import E1	INT32	1	100 GWh
32802	RW	Total Harmonic kWh Import E2	INT32	0.1	kWh
32804	RW	Total Harmonic kWh Export E1	INT32	1	100 GWh
32806	RW	Total Harmonic kWh Export E2	INT32	0.1	kWh
32808	RW	Total Harmonic kvarh Import E1	INT32	1	100 Gvarh
32810	RW	Total Harmonic kvarh Import E2	INT32	0.1	kvarh
32812	RW	Total Harmonic kvarh Export E1	INT32	1	100 Gvarh
32814	RW	Total Harmonic Export E2	INT32	0.1	kvarh
32816	RO	Total Harmonic kWh Net E1	INT32	1	100 GWh
32818	RO	Total Harmonic kWh Net E2	INT32	0.1	kWh
32820	RO	Total Harmonic kWh Total E1	INT32	1	100 GWh
32822	RO	Total Harmonic kWh Total E2	INT32	0.1	kWh
32824	RO	Total Harmonic kvarh Net E1	INT32	1	100 Gvarh
32826	RO	Total Harmonic kvarh Net E2	INT32	0.1	kvarh
32828	RO	Total Harmonic kvarh Total E1	INT32	1	100 Gvarh
32830	RO	Total Harmonic kvarh Total E2	INT32	0.1	kvarh
32832	RW	Fundamental kWh Import E1	INT32	1	100 GWh
32834	RW	Fundamental kWh Import E2	INT32	0.1	kWh
32836	RW	Fundamental kWh Export E1	INT32	1	100 GWh
32838	RW	Fundamental kWh Export E2	INT32	0.1	kWh
32840	RW	Fundamental kvarh Import E1	INT32	1	100 Gvarh
32842	RW	Fundamental kvarh Import E2	INT32	0.1	kvarh
32844	RW	Fundamental kvarh Export E1	INT32	1	100 Gvarh
32846	RW	Fundamental kvarh Export E2	INT32	0.1	kvarh
32848	RO	Fundamental kWh Net E1	INT32	1	100 GWh
32850	RO	Fundamental kWh Net E2	INT32	0.1	kWh
32852	RO	Fundamental kWh Total E1	INT32	1	100 GWh
32854	RO	Fundamental kWh Total E2	INT32	0.1	kWh
32856	RO	Fundamental kvarh Net E1	INT32	1	100 Gvarh
32858	RO	Fundamental kvarh Net E2	INT32	0.1	kvarh
32860	RO	Fundamental kvarh Total E1	INT32	1	100 Gvarh
32862	RO	Fundamental kvarh Total E2	INT32	0.1	kvarh

Table 5-22 Harmonic Energy (INT32)

5.12.8 Interharmonic Distortion Measurement

Register	Property	Description	Format	Unit/Scale
33100	RO	Ua/Uab TIHD ¹	FLOAT	%, x100
33102	RO	Ub/Ubc TIHD ¹	FLOAT	%, x100
33104	RO	Uc/Uca TIHD ¹	FLOAT	%, x100
33106	RO	U4 TIHD	FLOAT	%, x100
33108	RO	Ia TIHD	FLOAT	%, x100
33110	RO	Ib TIHD	FLOAT	%, x100
33112	RO	Ic TIHD	FLOAT	%, x100
33114	RO	I4 TIHD	FLOAT	%, x100
33116	--	Reserved	--	
33118	RO	Ua/Uab TOIHD ¹	FLOAT	%, x100
33120	RO	Ub/Ubc TOIHD ¹	FLOAT	%, x100
33122	RO	Uc/Uca TOIHD ¹	FLOAT	%, x100
33124	RO	U4 TOIHD	FLOAT	%, x100
33126	RO	Ia TOIHD	FLOAT	%, x100
33128	RO	Ib TOIHD	FLOAT	%, x100
33130	RO	Ic TOIHD	FLOAT	%, x100
33132	RO	I4 TOIHD	FLOAT	%, x100
33134	--	Reserved	--	
33136	RO	Ua/Uab TEIHD ¹	FLOAT	%, x100
33138	RO	Ub/Ubc TEIHD ¹	FLOAT	%, x100
33140	RO	Uc/Uca TEIHD ¹	FLOAT	%, x100
33142	RO	U4 TEIHD	FLOAT	%, x100
33144	RO	Ia TEIHD	FLOAT	%, x100
33146	RO	Ib TEIHD	FLOAT	%, x100
33148	RO	Ic TEIHD	FLOAT	%, x100
33150	RO	I4 TEIHD	FLOAT	%, x100
33152	--	Reserved	--	
33154	RO	Ua/Uab IHD00 ¹	FLOAT	%, x100
33156	RO	Ub/Ubc IHD00 ¹	FLOAT	%, x100
33158	RO	Uc/Uca IHD00 ¹	FLOAT	%, x100
33160	RO	U4 IHD00	FLOAT	%, x100
33162	RO	Ia IHD00	FLOAT	%, x100
33164	RO	Ib IHD00	FLOAT	%, x100
33166	RO	Ic IHD00	FLOAT	%, x100
33168	RO	I4 IHD00	FLOAT	%, x100
33170	--	Reserved	--	
33172	RO	Ua/Uab IHD01 ¹	FLOAT	%, x100
33174	RO	Ub/Ubc IHD01 ¹	FLOAT	%, x100
33176	RO	Uc/Uca IHD01 ¹	FLOAT	%, x100
33178	RO	U4 IHD01	FLOAT	%, x100
33180	RO	Ia IHD01	FLOAT	%, x100
33182	RO	Ib IHD01	FLOAT	%, x100
33184	RO	Ic IHD01	FLOAT	%, x100
33186	RO	I4 IHD01	FLOAT	%, x100
33188	--	Reserved	--	
...	
34288	RO	Ua/Uab IHD63 ¹	FLOAT	%, x100
34290	RO	Ub/Ubc IHD63 ¹	FLOAT	%, x100
34292	RO	Uc/Uca IHD63 ¹	FLOAT	%, x100
34294	RO	U4 IHD63	FLOAT	%, x100
34296	RO	Ia IHD63	FLOAT	%, x100
34298	RO	Ib IHD63	FLOAT	%, x100
34300	RO	Ic IHD63	FLOAT	%, x100
34302	RO	I4 IHD63	FLOAT	%, x100
34304	--	Reserved	--	

Table 5-23 Interharmonic Distortion Measurement

Note:

- 1) When the Wiring Mode is 3P3W, the Ua/Ub/Uc TIHD, TOIHD, TEIHD and Individual IHDs mean Uab/Ubc/Uca TIHD, TOIHD, TEIHD and Individual IHDs, respectively.

5.12.9 Interharmonic RMS Measurement

Register	Property	Description	Format	Unit
34500	RO	Ua/Uab TIH RMS ¹	FLOAT	V
34502	RO	Ub/Ubc TIH RMS ¹	FLOAT	V
34504	RO	Uc/Uca TIH RMS ¹	FLOAT	V
34506	RO	U4 TIH RMS	FLOAT	V
34508	RO	Ia TIH RMS	FLOAT	A
34510	RO	Ib TIH RMS	FLOAT	A
34512	RO	Ic TIH RMS	FLOAT	A
34514	RO	I4 TIH RMS	FLOAT	A
34516	--	Reserved	--	
34518	RO	Ua/Uab TOIH RMS ¹	FLOAT	V
34520	RO	Ub/Ubc TOIH RMS ¹	FLOAT	V
34522	RO	Uc/Uca TOIH RMS ¹	FLOAT	V
34524	RO	U4 TOIH RMS	FLOAT	V
34526	RO	Ia TOIH RMS	FLOAT	A
34528	RO	Ib TOIH RMS	FLOAT	A
34530	RO	Ic TOIH RMS	FLOAT	A
34532	RO	I4 TOIH RMS	FLOAT	A
34534	--	Reserved	--	
35436	RO	Ua/Uab TEIH RMS ¹	FLOAT	V
34538	RO	Ub/Ubc TEIH RMS ¹	FLOAT	V
34540	RO	Uc/Uca TEIH RMS ¹	FLOAT	V
34542	RO	U4 TEIH RMS	FLOAT	V
34544	RO	Ia TEIH RMS	FLOAT	A
34546	RO	Ib TEIH RMS	FLOAT	A
34548	RO	Ic TEIH RMS	FLOAT	A
34550	RO	I4 TEIH RMS	FLOAT	A
34552	--	Reserved	--	
34554	RO	Ua/Uab IH00 RMS ¹	FLOAT	V
34556	RO	Ub/Ubc IH00 RMS ¹	FLOAT	V
34558	RO	Uc/Uca IH00 RMS ¹	FLOAT	V
34560	RO	U4 IH00 RMS	FLOAT	V
34562	RO	Ia IH00 RMS	FLOAT	A
34564	RO	Ib IH00 RMS	FLOAT	A
34566	RO	Ic IH00 RMS	FLOAT	A
34568	RO	I4 IH00 RMS	FLOAT	A
34570	--	Reserved	--	
34572	RO	Ua/Uab IH01 RMS ¹	FLOAT	V
34574	RO	Ub/Ubc IH01 RMS ¹	FLOAT	V
34576	RO	Uc/Uca IH01 RMS ¹	FLOAT	V
34578	RO	U4 IH01 RMS	FLOAT	V
34580	RO	Ia IH01 RMS	FLOAT	A
34582	RO	Ib IH01 RMS	FLOAT	A
34584	RO	Ic IH01 RMS	FLOAT	A
34586	RO	I4 IH01 RMS	FLOAT	A
34588	--	Reserved	--	
...	RO	...	FLOAT	
35688	RO	Ua/Uab IH63 RMS ¹	FLOAT	V
35690	RO	Ub/Ubc IH63 RMS ¹	FLOAT	V
35692	RO	Uc/Uca IH63 RMS ¹	FLOAT	V
35694	RO	U4 IH63 RMS	FLOAT	V
35696	RO	Ia IH63 RMS	FLOAT	A
35698	RO	Ib IH63 RMS	FLOAT	A
35700	RO	Ic IH63 RMS	FLOAT	A
35702	RO	I4 IH63 RMS	FLOAT	A
35704	--	Reserved	--	

Table 5-24 Interharmonic RMS Measurement

Note:

- 1) When the Wiring Mode is 3P3W, the TIH/TOIH/TEIH RMS and Individual IH RMS for Ua/Ub/Uc mean TIH/TOIH/TEIH RMS and Individual IH RMS for Uab/Ubc/Uca, respectively.

5.13 Demand

5.13.1 Present Demand

Register	Property	Description	Format	Unit
3600	RO	Ua ¹	FLOAT	V
3602	RO	Ub ¹	FLOAT	V
3604	RO	Uc ¹	FLOAT	V
3606	RO	Uln Avg.	FLOAT	V
3608	RO	U4	FLOAT	V
3610	RO	Uab	FLOAT	V
3612	RO	Ubc	FLOAT	V
3614	RO	Uca	FLOAT	V
3616	RO	Ull Avg.	FLOAT	V
3618	RO	Ia	FLOAT	A
3620	RO	Ib	FLOAT	A
3622	RO	Ic	FLOAT	A
3624	RO	I Avg.	FLOAT	A
3626	RO	I4	FLOAT	A
3628	--	Reserved	--	A
3630	RO	Pa Imp. ¹	FLOAT	W
3632	RO	Pb Imp. ¹	FLOAT	W
3634	RO	Pc Imp. ¹	FLOAT	W
3636	RO	P Total Imp.	FLOAT	W
3638	RO	Pa Exp. ¹	FLOAT	W
3640	RO	Pb Exp. ¹	FLOAT	W
3642	RO	Pc Exp. ¹	FLOAT	W
3644	RO	P Total Exp.	FLOAT	W
3646	RO	Qa Imp. ¹	FLOAT	var
3648	RO	Qb Imp. ¹	FLOAT	var
3650	RO	Qc Imp. ¹	FLOAT	var
3652	RO	Q Total Imp.	FLOAT	var
3654	RO	Qa Exp. ¹	FLOAT	var
3656	RO	Qb Exp. ¹	FLOAT	var
3658	RO	Qc Exp. ¹	FLOAT	var
3660	RO	Q Total Exp.	FLOAT	var
3662	RO	Sa ¹	FLOAT	VA
3664	RO	Sb ¹	FLOAT	VA
3666	RO	Sc ¹	FLOAT	VA
3668	RO	S Total	FLOAT	VA
3670	RO	PFa ¹	FLOAT	--
3672	RO	PFb ¹	FLOAT	--
3674	RO	PFc ¹	FLOAT	--
3676	RO	PF Total	FLOAT	--
3678	RO	Frequency	FLOAT	Hz
3680	RO	Ua Deviation ¹	FLOAT	100%
3682	RO	Ub Deviation ¹	FLOAT	100%
3684	RO	Uc Deviation ¹	FLOAT	100%
3686	RO	Uab Deviation	FLOAT	100%
3688	RO	Ubc Deviation	FLOAT	100%
3690	RO	Uca Deviation	FLOAT	100%
3692	RO	Ua Over Deviation ¹	FLOAT	100%
3694	RO	Ub Over Deviation ¹	FLOAT	100%
3696	RO	Uc Over Deviation ¹	FLOAT	100%
3698	RO	Uab Over Deviation	FLOAT	100%
3700	RO	Ubc Over Deviation	FLOAT	100%
3702	RO	Uca Over Deviation	FLOAT	100%
3704	RO	Ua Under Deviation ¹	FLOAT	100%
3706	RO	Ub Under Deviation ¹	FLOAT	100%
3708	RO	Uc Under Deviation ¹	FLOAT	100%
3710	RO	Uab Under Deviation	FLOAT	100%

CET Electric Technology

3712	RO	Ubc Under Deviation	FLOAT	100%
3714	RO	Uca Under Deviation	FLOAT	100%
3716	RO	Frequency Deviation	FLOAT	100%
3718	RO	U0 Unbal.	FLOAT	
3720	RO	U2 Unbal.	FLOAT	
3722	RO	I0 Unbal.	FLOAT	
3724	RO	I2 Unbal.	FLOAT	
3726	RO	Ia K-Factor	FLOAT	
3728	RO	Ib K-Factor	FLOAT	
3730	RO	Ic K-Factor	FLOAT	
3732	RO	I4 K-Factor	FLOAT	
3734	--	Reserved	--	
3736	RO	Ua/Uab THD ²	FLOAT	
3738	RO	Ub/Ubc THD ²	FLOAT	
3740	RO	Uc/Uca THD ²	FLOAT	
3742	RO	U4 THD	FLOAT	
3744	RO	Ia THD	FLOAT	
3746	RO	Ib THD	FLOAT	
3748	RO	Ic THD	FLOAT	
3750	RO	I4 THD	FLOAT	
3752	--	Reserved	--	
3754	RO	Ua/Uab TOHD ²	FLOAT	
3756	RO	Ub/Ubc TOHD ²	FLOAT	
3758	RO	Uc/Uca TOHD ²	FLOAT	
3760	RO	U4 TOHD	FLOAT	
3762	RO	Ia TOHD	FLOAT	
3764	RO	Ib TOHD	FLOAT	
3766	RO	Ic TOHD	FLOAT	
3768	RO	I4 TOHD	FLOAT	
3770	--	Reserved	--	
3772	RO	Ua/Uab TEHD ²	FLOAT	
3774	RO	Ub/Ubc TEHD ²	FLOAT	
3776	RO	Uc/Uca TEHD ²	FLOAT	
3778	RO	U4 TEHD	FLOAT	
3780	RO	Ia TEHD	FLOAT	
3782	RO	Ib TEHD	FLOAT	
3784	RO	Ic TEHD	FLOAT	
3786	RO	I4 TEHD	FLOAT	
3788	--	Reserved	--	
3790	RO	Ia Fund.	FLOAT	A
3792	RO	Ib Fund.	FLOAT	A
3794	RO	Ic Fund.	FLOAT	A
3796	RO	I4 Fund.	FLOAT	A

Table 5-25 Present Demand

Notes:

- 1) When the Wiring Mode is 3P3W, the Present Demands for Ua/Ub/Uc, Uln Average, P Import/Export, Q Import/Export, S, PF, and Voltage Deviation, have no meaning and their registers are reserved.
- 2) When the Wiring Mode is 3P3W, the Present Demands for Ua/Ub/Uc THD, TOHD and TEHD mean the Demands for Uab/Ubc/Uca THD, TOHD and TEHD.

5.13.2 Predicted Demand

Register	Property	Description	Format	Unit
3900	RO	Ua ¹	FLOAT	V
3902	RO	Ub ¹	FLOAT	V
3904	RO	Uc ¹	FLOAT	V
3906	RO	Uln Avg.	FLOAT	V
3908	RO	U4	FLOAT	V
3910	RO	Uab	FLOAT	V
3912	RO	Ubc	FLOAT	V
3914	RO	Uca	FLOAT	V
3916	RO	Ull Avg.	FLOAT	V
3918	RO	Ia	FLOAT	A
3920	RO	Ib	FLOAT	A
3922	RO	Ic	FLOAT	A
3924	RO	I Avg.	FLOAT	A
3926	RO	I4	FLOAT	A
3928	--	Reserved	--	A
3930	RO	Pa Imp. ¹	FLOAT	W
3932	RO	Pb Imp. ¹	FLOAT	W
3934	RO	Pc Imp. ¹	FLOAT	W
3936	RO	P Total Imp.	FLOAT	W
3938	RO	Pa Exp. ¹	FLOAT	W
3940	RO	Pb Exp. ¹	FLOAT	W
3942	RO	Pc Exp. ¹	FLOAT	W
3944	RO	P Total Exp.	FLOAT	W
3946	RO	Qa Imp. ¹	FLOAT	var
3948	RO	Qb Imp. ¹	FLOAT	var
3950	RO	Qc Imp. ¹	FLOAT	var
3952	RO	Q Total Imp.	FLOAT	var
3954	RO	Qa Exp. ¹	FLOAT	var
3956	RO	Qb Exp. ¹	FLOAT	var
3958	RO	Qc Exp. ¹	FLOAT	var
3960	RO	Q Total Exp.	FLOAT	var
3962	RO	Sa ¹	FLOAT	VA
3964	RO	Sb ¹	FLOAT	VA
3966	RO	Sc ¹	FLOAT	VA
3968	RO	S Total	FLOAT	VA
3970	RO	PFa ¹	FLOAT	-
3972	RO	PFb ¹	FLOAT	-
3974	RO	PFc ¹	FLOAT	-
3976	RO	PF Total	FLOAT	-
3978	RO	Frequency	FLOAT	Hz
3980	RO	Ia Fund.	FLOAT	A
3982	RO	Ib Fund.	FLOAT	A
3984	RO	Ic Fund.	FLOAT	A
3986	RO	I4 Fund.	FLOAT	A

Table 5-26 Predicted Demand

Note:

- 1) When the Wiring Mode is 3P3W, the Predicted Demands for Ua/Ub/Uc, Uln Average, P Import/Export, Q Import/Export, S and PF, have no meaning and their registers are reserved.

5.13.3 Max. Value per Demand Period

Register	Property	Description	Format	Unit
4100	RO	Ua ¹	See Table 5-30	V
4106	RO	Ub ¹		
4112	RO	Uc ¹		
4118	RO	Uln Avg. ¹		
4124	RO	U4		
4130	RO	Uab		
4136	RO	Ubc		
4142	RO	Uca		
4148	RO	Ull Avg.		
4154	RO	Ia		A
4160	RO	Ib		
4166	RO	Ic		
4172	RO	I avg		
4178	RO	I4		
4184	RO	Reserved		
4190	RO	Pa Imp. ¹		W
4196	RO	Pb Imp. ¹		
4202	RO	Pc Imp. ¹		W
4208	RO	P Imp. Total		
4214	RO	Pa Exp. ¹		
4220	RO	Pb Exp. ¹		
4226	RO	Pc Exp. ¹		var
4232	RO	P Exp. Total		
4238	RO	Qa Imp. ¹		
4244	RO	Qb Imp. ¹		
4250	RO	Qc Imp. ¹		
4256	RO	Q Imp. Total		
4262	RO	Qa Exp. ¹		
4268	RO	Qb Exp. ¹		
4274	RO	Qc Exp. ¹		
4280	RO	Q Exp. Total		
4286	RO	Sa ¹		VA
4292	RO	Sb ¹		
4298	RO	Sc ¹		
4304	RO	S Total		
4310	RO	PFa ¹		
4316	RO	PFb ¹		
4322	RO	PFc ¹		
4328	RO	PF Total		
4334	RO	Frequency		Hz
4340	RO	Ua Deviation ¹		100%
4346	RO	Ub Deviation ¹		
4352	RO	Uc Deviation ¹		
4358	RO	Uab Deviation		
4364	RO	Ubc Deviation		
4370	RO	Uca Deviation		
4376	RO	Ua Over Deviation ¹		
4382	RO	Ub Over Deviation ¹		
4388	RO	Uc Over Deviation ¹		
4394	RO	Uab Over Deviation		
4400	RO	Ubc Over Deviation		
4406	RO	Uca Over Deviation		
4412	RO	Ua Under Deviation ¹		
4418	RO	Ub Under Deviation ¹		
4424	RO	Uc Under Deviation ¹		
4430	RO	Uab Under Deviation		
4436	RO	Ubc Under Deviation		
4442	RO	Uca Under Deviation		

CET Electric Technology

4448	RO	Frequency Deviation		
4454	RO	U0 Unbalance		
4460	RO	U2 Unbalance		
4466	RO	I0 Unbalance		
4472	RO	I2 Unbalance		
4478	RO	Ia K-Factor		
4484	RO	Ib K-Factor		
4490	RO	Ic K-Factor		
4496	RO	I4 K-Factor		
4502	RO	Reserved		
4508	RO	Ua/Uab THD ²		
4514	RO	Ub/Ubc THD ²		
4520	RO	Uc/Uca THD ²		
4526	RO	U4 THD		
4532	RO	Ia THD		
4538	RO	Ib THD		
4544	RO	Ic THD		
4550	RO	I4 THD		
4556	RO	Reserved		
4562	RO	Ua/Uab TOHD ²		
4568	RO	Ub/Ubc TOHD ²		
4574	RO	Uc/Uca TOHD ²		
4580	RO	U4 TOHD		
4586	RO	Ia TOHD		
4592	RO	Ib TOHD		
4598	RO	Ic TOHD		
4604	RO	I4 TOHD		
4610	RO	Reserved		
4616	RO	Ua/Uab TEHD ²		
4622	RO	Ub/Ubc TEHD ²		
4628	RO	Uc/Uca TEHD ²		
4634	RO	U4 TEHD		
4640	RO	Ia TEHD		
4646	RO	Ib TEHD		
4652	RO	Ic TEHD		
4658	RO	I4 TEHD		
4664	RO	Reserved		
4670	RO	Ia Fund.		A
4676	RO	Ib Fund.		A
4682	RO	Ic Fund.		A
4688	RO	I4 Fund.		A

Table 5-27 Max. Value per Demand Period

Notes:

- 1) When the Wiring Mode is 3P3W, the Max. Value per Demand Period for Ua/Ub/Uc, Uln Average, P Import/Export, Q Import/Export, S, PF, and Voltage Deviation, have no meaning and their registers are reserved.
- 2) When the Wiring Mode is 3P3W, the Max. Value per Demand Period for Ua/Ub/Uc THD, TOHD and TEHD mean the Demands for Uab/Ubc/Uca THD, TOHD and TEHD.

5.13.4 Min. Value per Demand Period

Register	Property	Description	Format	Unit
4800	RO	Ua ¹	See Table 5-30	V
4806	RO	Ub ¹		
4812	RO	Uc ¹		
4818	RO	Uln Avg. ¹		
4824	RO	U4		
4830	RO	Uab		
4836	RO	Ubc		
4842	RO	Uca		
4848	RO	Ull Avg.		
4854	RO	Ia		
4860	RO	Ib		
4866	RO	Ic		
4872	RO	I Avg.		
4878	RO	I4		
4884	--	Reserved		W
4890	RO	Pa Imp. ¹		
4896	RO	Pb Imp. ¹		
4902	RO	Pc Imp. ¹		
4908	RO	P Imp. Total		
4914	RO	Pa Exp. ¹		W
4920	RO	Pb Exp. ¹		
4926	RO	Pc Exp. ¹		
4932	RO	P Exp. Total		var
4938	RO	Qa Imp. ¹		
4944	RO	Qb Imp. ¹		
4950	RO	Qc Imp. ¹		
4956	RO	Q Imp. Total		
4962	RO	Qa Exp. ¹		
4968	RO	Qb Exp. ¹		
4974	RO	Qc Exp. ¹		
4980	RO	Q Exp. Total		VA
4986	RO	Sa ¹		
4992	RO	Sb ¹		
4298	RO	Sc ¹		Hz
5004	RO	S Total		
5010	RO	PFa ¹		100%
5016	RO	PFb ¹		
5022	RO	PFc ¹		
5028	RO	PF Total		
5034	RO	Freq.		
5040	RO	Ua Deviation ¹		
5046	RO	Ub Deviation ¹		
5052	RO	Uc Deviation ¹		
5058	RO	Uab Deviation		
5064	RO	Ubc Deviation		
5070	RO	Uca Deviation		
5076	RO	Ua Over Deviation ¹		
5082	RO	Ub Over Deviation ¹		
5088	RO	Uc Over Deviation ¹		
5094	RO	Uab Over Deviation		
5100	RO	Ubc Over Deviation		
5106	RO	Uca Over Deviation		
5112	RO	Ua Under Deviation ¹		
5118	RO	Ub Under Deviation ¹		
5124	RO	Uc Under Deviation ¹		
5130	RO	Uab Under Deviation		
5136	RO	Ubc Under Deviation		
5142	RO	Uca Under Deviation		

CET Electric Technology

5148	RO	Freq. Deviation	
5154	RO	U0 Unbalance	
5160	RO	U2 Unbalance	
5166	RO	I0 Unbalance	
5172	RO	I2 Unbalance	
5178	RO	Ia K-Factor	
5184	RO	Ib K-Factor	
5190	RO	Ic K-Factor	
5196	RO	I4 K-Factor	
5202	--	Reserved	
5208	RO	Ua/Uab THD ²	
5214	RO	Ub/Ubc THD ²	
5220	RO	Uc/Uca THD ²	
5226	RO	U4 THD	
5232	RO	Ia THD	
5238	RO	Ib THD	
5244	RO	Ic THD	
5250	RO	I4 THD	
5256	--	Reserved	
5262	RO	Ua/Uab TOHD ²	
5268	RO	Ub/Ubc TOHD ²	
5274	RO	Uc/Uca TOHD ²	
5280	RO	U4 TOHD	
5286	RO	Ia TOHD	
5292	RO	Ib TOHD	
5298	RO	Ic TOHD	
5304	RO	I4 TOHD	
5310	RO	Reserved	
5316	RO	Ua/Uab TEHD ²	
5322	RO	Ub/Ubc TEHD ²	
5328	RO	Uc/Uca TEHD ²	
5334	RO	U4 TEHD	
5340	RO	Ia TEHD	
5346	RO	Ib TEHD	
5352	RO	Ic TEHD	
5358	RO	I4 TEHD	
5364	--	Reserved	
5370	RO	Ia Fund.	A
5376	RO	Ib Fund.	A
5382	RO	Ic Fund.	A
5388	RO	I4 Fund.	A

Table 5-28 Min. Value per Demand Period

Notes:

- 1) When the Wiring Mode is 3P3W, the Min. Value per Demand Period for Ua/Ub/Uc, Uln Average, P Import/Export, Q Import/Export, S, PF, and Voltage Deviation, have no meaning and their registers are reserved.
- 2) When the Wiring Mode is 3P3W, the Min. Value per Demands for Ua/Ub/Uc THD, TOHD and TEHD mean the Demands for Uab/Ubc/Uca THD, TOHD and TEHD.

5.13.5 This/Last Max. Demand Log

This Max.	Last Max.	Property	Description	Format	Unit
5500	5700	RO	P Imp. Total	See Table 5-30	W
5506	5706	RO	P Exp. Total		W
5512	5712	RO	Q Imp. Total		var
5518	5718	RO	Q Exp. Total		var
5524	5724	RO	S Total		VA
5530	5730	RO	Ia		A
5536	5736	RO	Ib		A
5542	5742	RO	Ic		A
5548	5748	RO	Ia Fund.		A
5554	5754	RO	Ib Fund.		A
5560	5760	RO	Ic Fund.		A
5566	5766	RO	I4 Fund.		A
5572	5772	RO	I Avg.		

Table 5-29 This/Last Max. Demand Log

Note:

1) The following table illustrates Demand Data Structure:

Offset	Description
+0	High Year (-2000)
	Low Month
+1	High Day
	Low Hour
+2	High Minute
	Low Second
+3	- Reserved
+4~+5	- Record Value (Float)

Table 5-30 Demand Data Structure

5.14 Real-time IER and AER

5.14.1 Real-time 3-phase Total IER and AER (INT64)

The Energy registers will roll over to zero automatically when the maximum value is reached, which depends on the Energy Short Rollover's (Register 40758) setting:

- 0: maximum value of 100,000,000,000,000 (default)
- 1: maximum value of 1,000,000,000,000

IER	AER	Property	Description	Format	Unit
5800	5900	RO	Total RMS kWh Import	INT64	wh
5804	5904	RO	Total RMS kWh Export	INT64	wh
5808	5908	RO	Total RMS kWh Total	INT64	wh
5812	5912	RO	Total RMS kvarh Import	INT64	varh
5816	5916	RO	Total RMS kvarh Export	INT64	varh
5820	5920	RO	Total RMS kvarh Total	INT64	varh
5824	5924	RO	Total RMS kVAh Total	INT64	VAh
5828	5928	RO	Fundamental kWh Import	INT64	wh
5832	5932	RO	Fundamental kWh Export	INT64	wh
5836	5936	RO	Fundamental kvarh Import	INT64	varh
5840	5940	RO	Fundamental kvarh Export	INT64	varh
5844	5944	RO	Total Harmonic kWh Import	INT64	wh
5848	5948	RO	Total Harmonic kWh Export	INT64	wh
5852	5952	RO	Total Harmonic kvarh Import	INT64	varh
5856	5956	RO	Total Harmonic kvarh Export	INT64	varh
5860	5960	RO	Total RMS kWh Net	INT64	wh
5864	5964	RO	Total RMS kvarh Net	INT64	varh

Table 5-31 Real-time 3-phase Total IER and AER (INT64)

5.14.2 Real-time 3-phase Total IER and AER (INT32)

The Energy measurement should be calculated based on E1 & E2:
 $\sum kxh$ (Import/Export/Net/Total)

$$= E1 \times 100 \text{ GWh} + E2 \times 0.1 \text{ kWh}$$

$$= E1 \times 10^8 \text{ kWh} + E2 \times 0.1 \text{ kWh}$$

The E1 and E2 registers have a maximum value of 100 and 1000,000,000, respectively, and will roll over to zero automatically when it is reached. The E1 register will be incremented by 1 when the E2 register rolls over. The calculated Total kxh (Import/Export/Net/Total) has a maximum value of 1×10^{11} kxh. The E1 and E2 registers must be written simultaneously.

IER	AER	Property	Description	Format	Scale	Unit
6000	6100	RO	Total RMS kWh Import E1	INT32	1	100 GWh
6002	6102	RO	Total RMS kWh Import E2	INT32	0.1	kWh
6004	6104	RO	Total RMS kWh Export E1	INT32	1	100 GWh
6006	6106	RO	Total RMS kWh Export E2	INT32	0.1	kWh
6008	6108	RO	Total RMS kWh Total E1	INT32	1	100 GWh
6010	6110	RO	Total RMS kWh Total E2	INT32	0.1	kWh
6012	6112	RO	Total RMS kvarh Import E1	INT32	1	100 Gvarh
6014	6114	RO	Total RMS kvarh Import E2	INT32	0.1	kvarh
6016	6116	RO	Total RMS kvarh Export E1	INT32	1	100 Gvarh
6018	6118	RO	Total RMS kvarh Export E2	INT32	0.1	kvarh
6020	6120	RO	Total RMS kvarh Total E1	INT32	1	100 Gvarh
6022	6122	RO	Total RMS kvarh Total E2	INT32	0.1	kvarh
6024	6124	RO	Total RMS kVAh Total E1	INT32	1	100 GVAh
6026	6126	RO	Total RMS kVAh Total E2	INT32	0.1	GVAh
6028	6128	RO	Fundamental kWh Import E1	INT32	1	100 GWh
6030	6130	RO	Fundamental kWh Import E2	INT32	0.1	kWh
6032	6132	RO	Fundamental kWh Export E1	INT32	1	100 GWh
6034	6134	RO	Fundamental kWh Export E2	INT32	0.1	kWh
6036	6136	RO	Fundamental kvarh Import E1	INT32	1	100 Gvarh
6038	6138	RO	Fundamental kvarh Import E2	INT32	0.1	kvarh
6040	6140	RO	Fundamental kvarh Export E1	INT32	1	100 Gvarh
6042	6142	RO	Fundamental kvarh Export E2	INT32	0.1	kvarh
6044	6144	RO	Total Harmonic kWh Import E1	INT32	1	100 GWh
6046	6146	RO	Total Harmonic kWh Import E2	INT32	0.1	kWh
6048	6148	RO	Total Harmonic kWh Export E1	INT32	1	100 GWh
6050	6150	RO	Total Harmonic kWh Export E2	INT32	0.1	kWh
6052	6152	RO	Total Harmonic kvarh Import E1	INT32	1	100 Gvarh
6054	6154	RO	Total Harmonic kvarh Import E2	INT32	0.1	kvarh
6056	6156	RO	Total Harmonic kvarh Export E1	INT32	1	100 Gvarh
6058	6158	RO	Total Harmonic kvarh Export E2	INT32	0.1	kvarh
6060	6160	RO	Total RMS kWh Net E1	INT32	1	100 GWh
6062	6162	RO	Total RMS kWh Net E2	INT32	0.1	kWh
6064	6164	RO	Total RMS kvarh Net E1	INT32	1	100 Gvarh
6066	6166	RO	Total RMS kvarh Net E2	INT32	0.1	kvarh

Table 5-32 Real-time 3-phase Total IER and AER (INT32)

5.14.3 Real-time Per-phase IER and AER (INT64)

The Energy registers will roll over to zero automatically when the maximum value is reached, which depends on the **Energy Short Rollover's** (Register 40758) setting:

- 0: maximum value of 100,000,000,000,000 (default)
- 1: maximum value of 1,000,000,000,000

IER	AER	Property	Description	Format	Unit
7800	7950	RW	Phase A kWh Import	INT64	wh
7804	7954	RW	Phase A kWh Export	INT64	wh
7808	7958	RO	Phase A kWh Net	INT64	wh
7812	7962	RO	Phase A kWh Total	INT64	wh
7816	7966	RW	Phase A kvarh Import	INT64	varh
7820	7970	RW	Phase A kvarh Export	INT64	varh
7824	7974	RO	Phase A kvarh Net	INT64	varh
7828	7978	RO	Phase A kvarh Total	INT64	varh
7832	7982	RW	Phase A kVAh Total	INT64	VAh
7836	7986	RW	Phase B kWh Import	INT64	wh
7840	7990	RW	Phase B kWh Export	INT64	wh
7844	7994	RO	Phase B kWh Net	INT64	wh
7848	7998	RO	Phase B kWh Total	INT64	wh

7852	8002	RW	Phase B kvarh Import	INT64	varh
7856	8006	RW	Phase B kvarh Export	INT64	varh
7860	8010	RO	Phase B kvarh Net	INT64	varh
7864	8014	RO	Phase B kvarh Total	INT64	varh
7868	8018	RW	Phase B kVAh Total	INT64	VAh
7872	8022	RW	Phase C kWh Import	INT64	wh
7876	8026	RW	Phase C kWh Export	INT64	wh
7880	8030	RO	Phase C kWh Net	INT64	wh
7884	8034	RO	Phase C kWh Total	INT64	wh
7888	8038	RW	Phase C kvarh Import	INT64	varh
7892	8042	RW	Phase C kvarh Export	INT64	varh
7896	8046	RO	Phase C kvarh Net	INT64	varh
7900	8050	RO	Phase C kvarh Total	INT64	varh
7904	8054	RW	Phase C kVAh Total	INT64	VAh

Table 5-33 Real-time Per-phase IER and AER (INT64)

5.14.4 Real-time Per-phase IER and AER (INT32)

The Energy measurement should be calculated based on E1 & E2:

$$\sum kxh (\text{Import/Export/Net/Total})$$

$$= E1 \times 100 \text{ GWh} + E2 \times 0.1 \text{ kWh}$$

$$= E1 \times 10^8 \text{ kWh} + E2 \times 0.1 \text{ kWh}$$

The E1 and E2 registers have a maximum value of 100 and 1000,000,000, respectively, and will roll over to zero automatically when it is reached. The E1 register will be incremented by 1 when the E2 register rolls over. The calculated Total kXh (Import/Export/Net/Total) has a maximum value of 1×10^{11} kxh. The E1 and E2 registers must be written simultaneously.

IER	AER	Property	Description	Format	Scale	Unit
8100	8250	RW	Phase A kWh Import E1	INT32	1	100 GWh
8102	8252	RW	Phase A kWh Import E2	INT32	0.1	kWh
8104	8254	RW	Phase A kWh Export E1	INT32	1	100 GWh
8106	8256	RW	Phase A kWh Export E2	INT32	0.1	kWh
8108	8258	RO	Phase A kWh Net E1	INT32	1	100 GWh
8110	8260	RO	Phase A kWh Net E2	INT32	0.1	kWh
8112	8262	RO	Phase A kWh Total E1	INT32	1	100 GWh
8114	8264	RO	Phase A kWh Total E2	INT32	0.1	kWh
8116	8266	RW	Phase A kvarh Import E1	INT32	1	100 Gvarh
8118	8268	RW	Phase A kvarh Import E2	INT32	0.1	kvarh
8120	8270	RW	Phase A kvarh Export E1	INT32	1	100 Gvarh
8122	8272	RW	Phase A kvarh Export E2	INT32	0.1	kvarh
8124	8274	RO	Phase A kvarh Net E1	INT32	1	100 Gvarh
8126	8276	RO	Phase A kvarh Net E2	INT32	0.1	kvarh
8128	8278	RO	Phase A kvarh Total E1	INT32	1	100 Gvarh
8130	8280	RO	Phase A kvarh Total E2	INT32	0.1	kvarh
8132	8282	RW	Phase A kVAh Total E1	INT32	1	100 GVAh
8134	8284	RW	Phase A kVAh Total E2	INT32	0.1	kVAh
8136	8286	RW	Phase B kWh Import E1	INT32	1	100 GWh
8138	8288	RW	Phase B kWh Import E2	INT32	0.1	kWh
8140	8290	RW	Phase B kWh Export E1	INT32	1	100 GWh
8142	8292	RW	Phase B kWh Export E2	INT32	0.1	kWh
8144	8294	RO	Phase B kWh Net E1	INT32	1	100 GWh
8146	8296	RO	Phase B kWh Net E2	INT32	0.1	kWh
8148	8298	RO	Phase B kWh Total E1	INT32	1	100 GWh
8150	8300	RO	Phase B kWh Total E2	INT32	0.1	kWh
8152	8302	RW	Phase B kvarh Import E1	INT32	1	100 Gvarh
8154	8304	RW	Phase B kvarh Import E2	INT32	0.1	kvarh
8156	8306	RW	Phase B kvarh Export E1	INT32	1	100 Gvarh
8158	8308	RW	Phase B kvarh Export E2	INT32	0.1	kvarh
8160	8310	RO	Phase B kvarh Net E1	INT32	1	100 Gvarh
8162	8312	RO	Phase B kvarh Net E2	INT32	0.1	kvarh
8164	8314	RO	Phase B kvarh Total E1	INT32	1	100 Gvarh
8166	8316	RO	Phase B kvarh Total E2	INT32	0.1	kvarh
8168	8318	RW	Phase B kVAh Total E1	INT32	1	100 GVAh
8170	8320	RW	Phase B kVAh Total E2	INT32	0.1	kVAh
8172	8322	RW	Phase C kWh Import E1	INT32	1	100 GWh
8174	8324	RW	Phase C kWh Import E2	INT32	0.1	kWh
8176	8326	RW	Phase C kWh Export E1	INT32	1	100 GWh
8178	8328	RW	Phase C kWh Export E2	INT32	0.1	kWh
8180	8330	RO	Phase C kWh Net E1	INT32	1	100 GWh

8182	8332	RO	Phase C kWh Net E2	INT32	0.1	kWh
8184	8334	RO	Phase C kWh Total E1	INT32	1	100 GWh
8186	8336	RO	Phase C kWh Total E2	INT32	0.1	kWh
8188	8338	RW	Phase C kvarh Import E1	INT32	1	100 Gvarh
8190	8340	RW	Phase C kvarh Import E2	INT32	0.1	kvarh
8192	8342	RW	Phase C kvarh Export E1	INT32	1	100 Gvarh
8194	8344	RW	Phase C kvarh Export E2	INT32	0.1	kvarh
8196	8346	RO	Phase C kvarh Net E1	INT32	1	100 Gvarh
8198	8348	RO	Phase C kvarh Net E2	INT32	0.1	kvarh
8200	8350	RO	Phase C kvarh Total E1	INT32	1	100 Gvarh
8202	8352	RO	Phase C kvarh Total E2	INT32	0.1	kvarh
8204	8354	RW	Phase C kVAh Total E1	INT32	1	100 GVAh
8206	8356	RW	Phase C kVAh Total E2	INT32	0.1	kVAh

Table 5-34 Real-time Per-phase IER and AER (INT32)

5.15 2kHz - 150kHz C.E. Real-time Measurement

Register	Property	Description	Format	Unit
6200	RO	Timestamp-sec (UNIX) ¹	UINT32	s
6202	RO	Timestamp-ms (UNIX) ¹	UINT32	ms
6204	RO	Ua 2.1kHz Amplitude	FLOAT	
6206	RO	Ub 2.1kHz Amplitude	FLOAT	
6208	RO	Uc 2.1kHz Amplitude	FLOAT	
6210	RO	Ua 2.3kHz Amplitude	FLOAT	
6212	RO	Ub 2.3kHz Amplitude	FLOAT	
6214	RO	Uc 2.3kHz Amplitude	FLOAT	
6216	RO	Ua 2.5kHz Amplitude	FLOAT	
6218	RO	Ub 2.5kHz Amplitude	FLOAT	
6220	RO	Uc 2.5kHz Amplitude	FLOAT	
...	RO	...	FLOAT	
6408	RO	Ua 8.9kHz Amplitude	FLOAT	
6410	RO	Ub 8.9kHz Amplitude	FLOAT	
6412	RO	Uc 8.9kHz Amplitude	FLOAT	
6414	RO	Ua 10kHz Amplitude	FLOAT	
6416	RO	Ub 10kHz Amplitude	FLOAT	
6418	RO	Uc 10kHz Amplitude	FLOAT	
6420	RO	Ua 12kHz Amplitude	FLOAT	
6422	RO	Ub 12kHz Amplitude	FLOAT	
6424	RO	Uc 12kHz Amplitude	FLOAT	
6426	RO	Ua 14kHz Amplitude	FLOAT	
6428	RO	Ub 14kHz Amplitude	FLOAT	
6430	RO	Uc 14kHz Amplitude	FLOAT	
...	RO	...	FLOAT	
6834	RO	Ua 150kHz Amplitude	FLOAT	
6836	RO	Ub 150kHz Amplitude	FLOAT	
6838	RO	Uc 150kHz Amplitude	FLOAT	
6840	RO	Ia 2.1kHz Amplitude	FLOAT	
6842	RO	Ib 2.1kHz Amplitude	FLOAT	
6844	RO	Ic 2.1kHz Amplitude	FLOAT	
...	RO	...	FLOAT	
7044	RO	Ia 8.9kHz Amplitude	FLOAT	
7046	RO	Ib 8.9kHz Amplitude	FLOAT	
7048	RO	Ic 8.9kHz Amplitude	FLOAT	

Table 5-35 2kHz – 150kHz C.E. Real-time Measurement

Note:

1. The Second register and the Millisecond register must be read in a single transaction.

5.16 Data Logging

5.16.1 Device Log Buffer

The iMeter 7A can store up to 1024 entries in Device Logs. Writing N to the **Device Log Index** register will update the #N to #N+9 Device Log Buffer with Device Log Events. For example, if the **Device Log Pointer (Register 0137)** = 2000, writing 1991 to register 10000 will update the log buffer with the latest 10 logs and writing 977 will load the oldest 10 logs.

Register	Property	Description	Format
10000	RW	Device Log Index N*	UINT32
10002~10039	RO	Event #N	See Table 5-37
10040~10077	RO	Event #N+1	
...	RO	...	
10344~10381	RO	Event #N+9	

Table 5-36 Device Log Buffer

Offset	Property	Description	Format	Range
+0	RO	High-order Byte: Event Classification	UINT16	-
	RO	Low-order Byte: Sub-Classification	See Appendix B	
+1	RO	High-order Byte: Record Time - Year	UINT16	0-37 (Year-2000)
	RO	Low-order Byte: Record Time - Month		1 to 12
+2	RO	High-order Byte: Record Time - Day	UINT16	1 to 31
	RO	Low-order Byte: Record Time - Hour		0 to 23
+3	RO	High-order Byte: Record Time - Minute	UINT16	0 to 59
	RO	Low-order Byte: Record Time - Second		0 to 59
+4	RO	Record Time: Millisecond	UINT16	0 to 999
+5	RO	Reserved		
+6 to +37	RO	Event Values	See Appendix B	-

Table 5-37 Device Log Data Structure

5.16.2 SOE Log Buffer

The iMeter 7A can store up to 1024 entries of SOE Logs. Writing N to the **SOE Log Index** register will update the #N to #N+9 SOE Log Buffer with SOE Log Events. For example, if the **SOE Log Pointer (Register 0139)** = 2000, writing 1991 to register 10500 will update the log buffer with the latest 10 logs and writing 977 will load the oldest 10 logs.

Register	Property	Description	Format
10500	RW	SOE log Pointer N	UINT32
10502~10539	RO	Event #N	See Table 5-39
10540~10577	RO	Event #N+1	
...		...	
10844~10881	RO	Event #N+9	

Table 5-38 SOE Log Buffer

Offset	Property	Description	Format	Range
+0	RO	High-order Byte: Event Classification	UINT16	-
	RO	Low-order Byte: Sub-Classification		
+1	RO	High-order Byte: Record Time - Year	UINT16	0-37 (Year-2000)
	RO	Low-order Byte: Record Time - Month		1 to 12
+2	RO	High-order Byte: Record Time - Day	UINT16	1 to 31
	RO	Low-order Byte: Record Time - Hour		0 to 23
+3	RO	High-order Byte: Record Time - Minute	UINT16	0 to 59
	RO	Low-order Byte: Record Time - Second		0 to 59
+4	RO	Record Time: Millisecond	UINT16	0 to 999
+5	--	Reserved		
+6 to +37	RO	Event Values	See Appendix C	-

Table 5-39 SOE Log Data Structure

5.16.3 Latest PQD Log

5.16.3.1 PQD Log Buffer

Register	Property	Description	Format
22000-22035	RO	The Latest Swell Event	See Table 5-41
22036-22071	RO	The Latest Dip Event	
22072-22107	RO	The Latest Interruption Event	

Table 5-40 POD Log Buffer

5.16.3.2 PQD Log Data Structure

Offset	Property	Description	Format	Range	
+0	RO	Record Time	High Order - Year	UINT16	0-37 (Year-2000)
	RO		Low Order - Month		1 to 12
+1	RO		High Order - Day	UINT16	1 to 31
	RO		Low Order - Hour		0 to 23
+2	RO		High Order - Minute	UINT16	0 to 59
	RO		Low Order - Second		0 to 59
+3	RO		Millisecond	UINT16	0 to 999
+4 to +5	--		Reserved	--	-
+6	RO	Source	UINT32	1=Ua, 2=Ub, 3=Uc, 4=Uab, 5=Ubc, 6=Uca	
+8	RO	Peak Residual Voltage (%)	FLOAT	-	
+10	RO	Duration (ms)	UINT32	-	
+12	RO	Ua Residual Voltage (%)	FLOAT	-	
+14	RO	Ub Residual Voltage (%)	FLOAT	-	
+16	RO	Uc Residual Voltage (%)	FLOAT	-	
+18	RO	Disturbance Direction	UINT32	1=Upstream, 2=Downstream	
+20	RO	Confidence	UINT32	1=Low, 2=Middle, 3=High	
+22	RO	Ua Benchmark (Primary)	FLOAT	-	
+24	RO	Ub Benchmark (Primary)	FLOAT	-	
+26	RO	Uc Benchmark (Primary)	FLOAT	-	
+28	--	Reserved	--	-	
+30	RO	Location in SEMI F47 Plot	UINT32	0=Reserved 1=Region A (undefined), 2=Region B (no interruption), 3=Region C (probable abnormal operation), 4=Region D (undefined)	
+32	RO	Location in ITIC Plot	UINT32	0=Reserved 1=Region A (no interruption in function) 2=Region B (no damage) 3=Region C (Prohibited)	
+34	--	Reserved	--	-	

Table 5-41 PQD Log Data Structure

5.16.4 Statistical Data Recorder

Register	Property	Description	Format
11000~11518	RO	SDR #1 Log Buffer	See Section 5.16.4.1
11600~12118	RO	SDR #2 Log Buffer	
12200~12718	RO	SDR #3 Log Buffer	
12800~13318	RO	SDR #4 Log Buffer	
13400~13918	RO	SDR #5 Log Buffer	
14000~14518	RO	SDR #6 Log Buffer	
14600~15118	RO	SDR #7 Log Buffer	
15200~15718	RO	SDR #8 Log Buffer	

Table 5-42 SDR Log Buffer

5.16.4.1 SDR Log Structure

The iMeter 7A provides 8 groups of SDR with each recording depth of 43200. Writing N to the **SDR Log #X Index** register will update the #N to #N+63 Data Item of SDR #X Log Buffer. For example, if the **SDR Log #1 Pointer (Register 0159)** = 50000 (providing the recording mode = First-In-First-Out), writing 50000 to register 11000 will load the latest 64 Data Items and writing 6801 will load the oldest 64 Data Items to the SDR #1 Log Buffer.

Offset	Property	Description	Format	Note
+0	RW	SDR Log # X Index N (1≤X≤8)	UINT32	-
+2~+4	RO	Record Time	See Note 1	
+5	RO	Flagging Data Status ²	UINT16	0=Not Flagged 1=Flagged & Removed 2=Flagged & Kept
+6~+13	RO	Data Item #N	See Note 3	-
+14~+21	RO	Data Item #N+1		
...		...		
+510~+517	RO	Data Item #N+63		

Table 5-43 SDR Log Buffer Structure

Notes:

1. Record Time Data Structure

Offset	Property	Description	Format	Unit
+0	RO	Year	UINT16	0-37 (Year-2000)
	RO	Month		1 to 12
+1	RO	Day	UINT16	1 to 31
	RO	Hour		0 to 23
+2	RO	Minute	UINT16	0 to 59
	RO	Second		0 to 59

Table 5-44 Record Time Data Structure

2. For SDR Log, if the corresponding **Eliminate Flagged Data** (Register 40825) is set to Remove, the log entry will be discarded and will not be included in the statistical evaluation if any data within the log entry has been Flagged. And in the **Flagging Status** registers, a value of "0" indicates no flagged data, and "1" indicates that a certain group of data has been flagged and removed while "2" indicates the flagged data has been kept.

3. SDR Data Item Structure

Offset	Property	Description	Format
+0	RO	Maximum	FLOAT
+2	RO	Minimum	FLOAT
+4	RO	Average	FLOAT
+6	RO	CP95	FLOAT

Table 5-45 SDR Data Item Structure

5.16.5 DR (Data Recorder) Log

The iMeter 7A provides 8 groups of DR with each recording depth of 65535. Writing N to the **DR #X Log Index N** register will update the #N to #N+63 Data Item of DR #X Log Buffer. For example, if the **DR #1 Log Pointer (Register 0207) = 50000** (providing the recording mode = First-In-First-Out), writing 50000 to register 20600 will load the latest 64 Data Items and writing 1 will load the oldest 64 Data Items to the DR #1 Log Buffer.

Register	Property	Description	Format
20600-20733	RO	Data Recorder #1 Log Buffer	See Table 5-47
20735-20869	RO	Data Recorder #2 Log Buffer	
20870-21004	RO	Data Recorder #3 Log Buffer	
21005-21139	RO	Data Recorder #4 Log Buffer	
21140-21274	RO	Data Recorder #5 Log Buffer	
21275-21409	RO	Data Recorder #6 Log Buffer	
21410-21544	RO	Data Recorder #7 Log Buffer	
21545-21679	RO	Data Recorder #8 Log Buffer	

Table 5-46 DR Log Buffer

Offset	Properties	Format	Description
+0	RW	UINT32	Data Recorder Log #X Index N
+2	RO	UINT16	High-order: Year (-2000) Low-order: Month (1 to 12)
+3	RO		High-order: Day (1 to 31) Low-order: Hour (0 to 23)
+4	RO		High-order: Minute (0 to 59) Low-order: Second (0 to 59)
+5	RO		Millisecond (0 to 999)
+6	RO	UINT16	0=Not Flagged, 1=Flagged
+7	RO	FLOAT	Parameter 1
...	RO	FLOAT	...
+37	RO	FLOAT	Parameter 16
+38	RO	FLOAT	Parameter 17
...	RO	FLOAT	...
+133	RO	FLOAT	Parameter 64

Table 5-47 Data Recorder Log Structure

5.16.6 Max./Min. Log

5.16.6.1 MM Log Buffer

Register	Description	Format
22200-22306	Max. #1 Log Buffer	See Section 5.16.6.2
22350~22456	Max. #2 Log Buffer	
22500~22606	Max. #3 Log Buffer	
22650~22756	Max. #4 Log Buffer	
22800~22906	Min. #1 Log Buffer	
22950~23056	Min. #2 Log Buffer	
23100~23206	Min. #3 Log Buffer	
23250~23356	Min. #4 Log Buffer	

Table 5-48 MM Log Buffer

5.16.6.2 MM Log Buffer Structure

Offset	Property	Description	Format	Range/Options
+0	RW	Max./Min. #X Log Index N	UINT32	0=Since Last Reset/This Month 1=Before Last Reset/Last Month
+2	RO	Record Time		See Table 5-50
+5	RO	Flagging Data Status ²	UINT16	0=Not Flagged 1=Flagged & Removed 2=Flagged & kept
+6~+10	RO	Data Item #1		See Table 5-51
+11~+15	RO	Data Item #2		
...	RO	...		
+101~+105	RO	Data Item #20		

Table 5-49 Max./Min. Log Data Structure

Notes:

1. Please refer to **Table 5-50** for the Recording Time data structure. Please note that the Recording Time means the Start Time of a Max. Recorder while the End Time of a Min. Recorder.

Offset	Property	Description	Format	Range
+0	RO	Year	UINT16	0-37 (Year-2000)
	RO	Month		1 to 12
+1	RO	Day	UINT16	1 to 31
	RO	Hour		0 to 23
+2	RO	Minute	UINT16	0 to 59
	RO	Second		0 to 59

Table 5-50 Time Structure

2. For Max./Min. Log, if the corresponding Flagged Data Setup (Register **40825**) is set to Remove, the log entry will be discarded and will not be included in the statistical evaluation if any data within the log entry has been Flagged. And in the Flagging Status registers, a value of "0" indicates no flagged data, and "1" indicates that a certain group of data has been flagged and removed while "2" indicates the flagged data has been kept.
3. The following table illustrates the data structure of the MM Log.

Offset	Property	Description		
+0	RO	Timestamp	Hi	Year (-2000)
			Low	Month
+1	RO		Hi	Day
			Low	Hour
+2	RO		Hi	Minute
			Low	Second
+3~+4	RO	Max. or Min. Value (FLOAT)		

Table 5-51 MM Data Structure

5.16.7 Pst/Plt Log

5.16.7.1 Pst Log Buffer

The iMeter 7A can store up to 52560 Pst Log based on a First-In-First-Out principle. Writing N to **Pst Log Index** register will update the #N to #N+9 log of the Log Buffer. For example, if the **Pst Log Pointer (Register 0239)** = 60000, writing 59991 to register 23400 will load the latest 10 log buffers and writing 7441 will load the oldest 10 log buffers.

Register	Property	Description	Format
23400	RW	Pst Log Index (N)	UINT32
23402~23411	RO	Log N	See Section 5.16.7.3
23412~23421	RO	Log N+1	
...		...	
23492~23501	RO	Log N+9	

Table 5-52 Pst Log Buffer

5.16.7.2 Plt Log Buffer

The iMeter 7A can store up to 4380 Plt Log based on a First-In-First-Out principle. Writing N to **Plt Log Index** register will update the #N to #N+9 log of the Log Buffer. For example, if the **Plt Log Pointer (Register 0241)** = 5000, writing 4990 to register 23601 will load the latest 10 log buffers and writing 621 will load the oldest 10 log buffers.

Register	Property	Description	Format
23600	RW	Plt Log Index (N)	UINT32
23602~23611	RO	Log N	See Section 5.16.7.3
23612~23621	RO	Log N+1	
...		...	
23692~23701	RO	Log N+9	

Table 5-53 Plt Log

5.16.7.3 Pst/Plt Log Data Structure

Offset	Property	Description	Format	Range/Unit	
+0	RO	Record Time	High-Year (-2000)	UINT16	0-37 (Year-2000)
			Low- Month		1 to 12
+1	RO		High- Day	UINT16	1 to 31
			Low- Hour		0 to 23
+2	RO		High- Minute	UINT16	0 to 59
			Low- Second		0 to 59
+3	RO	Flagging Status ¹	BITMAP	See Note 1	

+4~+5	RO	Ua Pst/Plt	FLOAT	V
+6~+7	RO	Ub Pst/Plt	FLOAT	V
+8~+9	RO	Uc Pst/Plt	FLOAT	V

Table 5-54 Pst/Plt Log Data Structure

Note:

- In the **Flagging Status** register for Pst and Plt Log, a value of “1” indicates that a certain group of data has been flagged due to Dip (BIT0), Swell (BIT1) and/or Interruption (BIT2).

5.16.8 IER & AER Log

The iMeter 7A can store up to 65535 IER and AER Logs for 3-phase total and per-phase, independently. Writing N to the **IER/AER Log Index** will update the #N (to #N+1) Log Buffer. For example, if the **3-phase Total IER Log Pointer (Register 0245)** = 65530, writing 65529 to register 23800 to update the log buffer with the latest 2 logs and writing 1 to load the oldest 2 logs. If the IER Log pointer exceeds 65530, take 65540 as an example, writing 65539 (65540-1=65539) to the register 23800 to update the log buffer with the latest 2 logs and writing 6 (65540-65535+1=6) to load the oldest 2 logs.

5.16.8.1 3-phase Total IER/AER Log (INT64)

IER	AER	Property	Description	Format
23800	24000	RW	IER/AER Log Index N	UINT32
23802~23875	24002~24075	RO	Log #N	See Section 5.16.8.2
23876~23949	24076~24149	RO	Log #N+1	

Table 5-55 3-phase Total IER/AER Log Buffer (INT64)

5.16.8.2 3-phase Total IER & AER Log Data Structure (INT64)

Offset	Property	Description	Format	Note
+0~+2	RO	Start Time ¹	UINT16	
+3~+5	RO	End Time ¹	UINT16	
+6~+9	RO	RMS kWh Import	INT64	
+10~+13	RO	RMS kWh Export	INT64	
+14~+17	RO	RMS kWh Total	INT64	
+18~+21	RO	RMS kvarh Import	INT64	
+22~+25	RO	RMS kvarh Export	INT64	
+26~+29	RO	RMS kvarh Total	INT64	
+30~+33	RO	RMS kVAh Total	INT64	
+34~+37	RO	Fundamental kWh Import	INT64	
+38~+41	RO	Fundamental kWh Export	INT64	
+42~+45	RO	Fundamental kvarh Import	INT64	
+46~+49	RO	Fundamental kvarh Export	INT64	
+50~+53	RO	Harmonic kWh Import	INT64	
+54~+57	RO	Harmonic kWh Export	INT64	
+58~+61	RO	Harmonic kvarh Import	INT64	
+62~+65	RO	Harmonic kvarh Export	INT64	
+66~+69	RO	RMS kWh Net	INT64	
+70~+73	RO	RMS kvarh Net	INT64	

Table 5-56 3-phase Total IER & AER Log Data Structure (INT64)

Note:

- The following table illustrates the Data Structure of the Start/End Time.

Offset	Property	Description	Format	Unit
+0	RO	Year	UINT16	0-37 (Year-2000)
	RO	Month		1 to 12
+1	RO	Day	UINT16	1 to 31
	RO	Hour		0 to 23
+2	RO	Minute	UINT16	0 to 59
	RO	Second		0 to 59

Table 5-57 Time Structure

5.16.8.3 Per-phase IER/AER Log (INT64)

IER	AER	Property	Description	Format
24200	24350	RW	IER/AER Log Index N	UINT32
24202~24315	24352~24464	RO	Log #N	See Section 5.16.8.4

Table 5-58 Per-phase IER/AER Log Buffer (INT64)

5.16.8.4 Per-phase IER & AER Log Data Structure (INT64)

Offset	Property	Description	Format	Note
+0~+2	RO	Start Time ¹	UINT16	
+3~+5	RO	End Time ¹	UINT16	
+6~+9	RO	Phase A kWh Import	INT64	
+10~+13	RO	Phase A kWh Export	INT64	
+14~+17	RO	Phase A kWh Net	INT64	
+18~+21	RO	Phase A kWh Total	INT64	
+22~+25	RO	Phase A kvarh Import	INT64	
+26~+29	RO	Phase A kvarh Export	INT64	
+30~+33	RO	Phase A kvarh Net	INT64	
+34~+37	RO	Phase A kvarh Total	INT64	
+38~+41	RO	Phase A kVAh Total	INT64	
+42~+45	RO	Phase B kWh Import	INT64	
+46~+49	RO	Phase B kWh Export	INT64	
+50~+53	RO	Phase B kWh Net	INT64	
+54~+57	RO	Phase B kWh Total	INT64	
+58~+61	RO	Phase B kvarh Import	INT64	
+62~+65	RO	Phase B kvarh Export	INT64	
+66~+69	RO	Phase B kvarh Net	INT64	
+70~+73	RO	Phase B kvarh Total	INT64	
+74~+77	RO	Phase B kVAh Total	INT64	
+78~+81	RO	Phase C kWh Import	INT64	
+82~+85	RO	Phase C kWh Export	INT64	
+86~+89	RO	Phase C kWh Net	INT64	
+90~+93	RO	Phase C kWh Total	INT64	
+94~+97	RO	Phase C kvarh Import	INT64	
+98~+101	RO	Phase C kvarh Export	INT64	
+102~+105	RO	Phase C kvarh Net	INT64	
+106~+109	RO	Phase C kvarh Total	INT64	
+110~+113	RO	Phase C kVAh Total	INT64	

Table 5-59 Per-phase IER & AER Log Data Structure (INT64)

Note:

2. The following table illustrates the Data Structure of the Start/End Time.

Offset	Property	Description	Format	Unit
+0	RO	Year	UINT16	0-37 (Year-2000)
	RO	Month		1 to 12
+1	RO	Day	UINT16	1 to 31
	RO	Hour		0 to 23
+2	RO	Minute	UINT16	0 to 59
	RO	Second		0 to 59

Table 5-60 Time Structure

5.16.8.5 3-phase Total IER/AER Log (INT32)

IER	AER	Property	Description	Format
24500	25000	RW	IER/AER Log Index N	UINT32
24502~24575	25002~25075	RO	Log #N	See Section 5.16.8.6
24576~24649	25076~25149	RO	Log #N+1	

Table 5-61 3-phase Total IER & AER Log Buffer (INT32)

5.16.8.6 3-phase Total IER/AER Log Data Structure (INT32)

Offset	Property	Description	Format	Note
+0~+2	RO	Start Time ¹	UINT16	
+3~+5	RO	End Time	UINT16	
+6~+7	RO	Total RMS kWh Import E1	INT32	
+8~+9	RO	Total RMS kWh Import E2	INT32	
+10~+11	RO	Total RMS kWh Export E1	INT32	
+12~+13	RO	Total RMS kWh Export E2	INT32	
+14~+15	RO	Total RMS kWh Total E1	INT32	
+16~+17	RO	Total RMS kWh Total E2	INT32	
+18~+19	RO	Total RMS kvarh Import E1	INT32	
+20~+21	RO	Total RMS kvarh Import E2	INT32	
+22~+23	RO	Total RMS kvarh Export E1	INT32	

+24~+25	RO	Total RMS kvarh Export E2	INT32	
+26~+27	RO	Total RMS kvarh Total E1	INT32	
+28~+29	RO	Total RMS kvarh Total E2	INT32	
+30~+31	RO	Total RMS kVAh Total E1	INT32	
+32~+33	RO	Total RMS kVAh Total E2	INT32	
+34~+35	RO	Fundamental kWh Import E1	INT32	
+36~+37	RO	Fundamental kWh Import E2	INT32	
+38~+39	RO	Fundamental kWh Export E1	INT32	
+40~+41	RO	Fundamental kWh Export E2	INT32	
+42~+43	RO	Fundamental kvarh Import E1	INT32	
+44~+45	RO	Fundamental kvarh Import E2	INT32	
+46~+47	RO	Fundamental kvarh Export E1	INT32	
+48~+49	RO	Fundamental kvarh Export E2	INT32	
+50~+51	RO	Total Harmonic kWh Import E1	INT32	
+52~+53	RO	Total Harmonic kWh Import E2	INT32	
+54~+55	RO	Total Harmonic kWh Export E1	INT32	
+56~+57	RO	Total Harmonic kWh Export E2	INT32	
+58~+59	RO	Total Harmonic kvarh Import E1	INT32	
+60~+61	RO	Total Harmonic kvarh Import E2	INT32	
+62~+63	RO	Total Harmonic kvarh Export E1	INT32	
+64~+65	RO	Total Harmonic kvarh Export E2	INT32	
+66~+67	RO	Total RMS kWh Net E1	INT32	
+68~+69	RO	Total RMS kWh Net E2	INT32	
+70~+71	RO	Total RMS kvarh Net E1	INT32	
+72~+73	RO	Total RMS kvarh Net E2	INT32	

Table 5-62 3-phase Total IER & AER Log Data Structure (INT32)

Note:

- The following table illustrates the Data Structure of the Start/End Time.

Offset	Property	Description	Format	Unit
+0	RO	Year	UINT16	0-37 (Year-2000)
	RO	Month		1 to 12
+1	RO	Day	UINT16	1 to 31
	RO	Hour		0 to 23
+2	RO	Minute	UINT16	0 to 59
	RO	Second		0 to 59

Table 5-63 Time Structure

5.16.8.7 Per-phase IER/AER Log (INT32)

IER	AER	Property	Description	Format
24700	24850	RW	IER/AER Log Index N	UINT32
24702~24815	24852~24965	RO	Log #N	See Section 5.16.8.6

Table 5-64 Per-phase IER & AER Log Buffer (INT32)

5.16.8.8 Per-phase IER/AER Log Data Structure (INT32)

Offset	Property	Description	Format	Note
+0~+2	RO	Start Time ¹	UINT16	
+3~+5	RO	End Time	UINT16	
+6~+7	RO	Phase A kWh Import E1	INT32	
+8~+9	RO	Phase A kWh Import E2	INT32	
+10~+11	RO	Phase A kWh Export E1	INT32	
+12~+13	RO	Phase A kWh Export E2	INT32	
+14~+15	RO	Phase A kWh Net E1	INT32	
+16~+17	RO	Phase A kWh Net E2	INT32	
+18~+19	RO	Phase A kWh Total E1	INT32	
+20~+21	RO	Phase A kWh Total E2	INT32	
+22~+23	RO	Phase A kvarh Import E1	INT32	
+24~+25	RO	Phase A kvarh Import E2	INT32	
+26~+27	RO	Phase A kvarh Export E1	INT32	
+28~+29	RO	Phase A kvarh Export E2	INT32	
+30~+31	RO	Phase A kvarh Net E1	INT32	
+32~+33	RO	Phase A kvarh Net E2	INT32	
+34~+35	RO	Phase A kvarh Total E1	INT32	
+36~+37	RO	Phase A kvarh Total E2	INT32	
+38~+39	RO	Phase A kVAh Total E1	INT32	

+40~+41	RO	Phase A kVAh Total E2	INT32	
+42~+43	RO	Phase B kWh Import E1	INT32	
+44~+45	RO	Phase B kWh Import E2	INT32	
+46~+47	RO	Phase B kWh Export E1	INT32	
+48~+49	RO	Phase B kWh Export E2	INT32	
+50~+51	RO	Phase B kWh Net E1	INT32	
+52~+53	RO	Phase B kWh Net E2	INT32	
+54~+55	RO	Phase B kWh Total E1	INT32	
+56~+57	RO	Phase B kWh Total E2	INT32	
+58~+59	RO	Phase B kvarh Import E1	INT32	
+60~+61	RO	Phase B kvarh Import E2	INT32	
+62~+63	RO	Phase B kvarh Export E1	INT32	
+64~+65	RO	Phase B kvarh Export E2	INT32	
+66~+67	RO	Phase B kvarh Net E1	INT32	
+68~+69	RO	Phase B kvarh Net E2	INT32	
+70~+71	RO	Phase B kvarh Total E1	INT32	
+72~+73	RO	Phase B kvarh Total E2	INT32	
+74~+75	RO	Phase B kVAh Total E1	INT32	
+76~+77	RO	Phase B kVAh Total E2	INT32	
+78~+79	RO	Phase C kWh Import E1	INT32	
+80~+81	RO	Phase C kWh Import E2	INT32	
+82~+83	RO	Phase C kWh Export E1	INT32	
+84~+85	RO	Phase C kWh Export E2	INT32	
+86~+87	RO	Phase C kWh Net E1	INT32	
+88~+89	RO	Phase C kWh Net E2	INT32	
+90~+91	RO	Phase C kWh Total E1	INT32	
+92~+93	RO	Phase C kWh Total E2	INT32	
+94~+95	RO	Phase C kvarh Import E1	INT32	
+96~+97	RO	Phase C kvarh Import E2	INT32	
+98~+99	RO	Phase C kvarh Export E1	INT32	
+100~+101	RO	Phase C kvarh Export E2	INT32	
+102~+103	RO	Phase C kvarh Net E1	INT32	
+104~+105	RO	Phase C kvarh Net E2	INT32	
+106~+107	RO	Phase C kvarh Total E1	INT32	
+108~+109	RO	Phase C kvarh Total E2	INT32	
+110~+111	RO	Phase C kVAh Total E1	INT32	
+112~+113	RO	Phase C kVAh Total E2	INT32	

Table 5-65 Per-phase IER & AER Log Data Structure (INT32)

Note:

- The following table illustrates the Data Structure of the Start/End Time.

Offset	Property	Description	Format	Unit
+0	RO	Year	UINT16	0-37 (Year-2000)
	RO	Month		1 to 12
+1	RO	Day	UINT16	1 to 31
	RO	Hour		0 to 23
+2	RO	Minute	UINT16	0 to 59
	RO	Second		0 to 59

Table 5-66 Time Structure

5.16.9 IEEE Std 519-2022 Report

The iMeter 7A can independently store up to 365 IEEE Std 519-2022 daily reports and 53 weekly reports. Writing N to the **Log Index** will update the daily report / weekly report Log Buffer. For example, if the **IEEE Std 519-2022 Daily Report Log Pointer (Register 0265) = 366**, writing 366 to register 25202 will update the log buffer with the latest daily report.

Register	Property	Description	Format	Unit	Note
25200	RW	Log type	UINT32		0=Weekly Report, 1=Daily Report
25202	RW	Log index N	UINT32		
25204~ 25206	RO	Start time ¹	UINT16		
25207~ 25209	RO	End time ¹	UINT16		
25210	RO	U harmonic compliance conclusion	UINT32		BIT0: 0=Pass, 1=Fail
25212	RO	U harmonic valid evaluation interval	UINT32		

CET Electric Technology

25214	RO	U harmonic invalid evaluation interval	UINT32		
25216	RO	U THD compliance conclusion	UINT32		BIT0: 0=Pass, 1=Fail
25218	RO	I harmonic compliance conclusion	UINT32		BIT0: 0=Pass, 1=Fail
25220	RO	I harmonic valid evaluation interval	UINT32		
25222	RO	I harmonic invalid evaluation interval	UINT32		
25224	RO	TDD compliance conclusion	UINT32		BIT0: 0=Pass, 1=Fail
25226	RO	Ua / Uab THD CP95 value	FLOAT	%/x100	
25228	RO	Ua / Uab THD CP99 value	FLOAT	%/x100	
25230	RO	Ub / Ubc THD CP95 value	FLOAT	%/x100	
25232	RO	Ub / Ubc THD CP99 value	FLOAT	%/x100	
25234	RO	Uc / Uca THD CP95 value	FLOAT	%/x100	
25236	RO	Uc / Uca THD CP99 value	FLOAT	%/x100	
25238	RO	Ua / Uab TOHD CP95 value	FLOAT	%/x100	
25240	RO	Ua / Uab TOHD CP99 value	FLOAT	%/x100	
25242	RO	Ub / Ubc TOHD CP95 value	FLOAT	%/x100	
25244	RO	Ub / Ubc TOHD CP99 value	FLOAT	%/x100	
25246	RO	Uc / Uca TOHD CP95 value	FLOAT	%/x100	
25248	RO	Uc / Uca TOHD CP99 value	FLOAT	%/x100	
25250	RO	Ua / Uab TEHD CP95 value	FLOAT	%/x100	
25252	RO	Ua / Uab TEHD CP99 value	FLOAT	%/x100	
25254	RO	Ub / Ubc TEHD CP95 value	FLOAT	%/x100	
25256	RO	Ub / Ubc TEHD CP99 value	FLOAT	%/x100	
25258	RO	Uc / Uca TEHD CP95 value	FLOAT	%/x100	
25260	RO	Uc / Uca TEHD CP99 value	FLOAT	%/x100	
25262	RO	Ua / Uab HD02 CP95 value	FLOAT	%/x100	
25264	RO	Ua / Uab HD02 CP99 value	FLOAT	%/x100	
25266	RO	Ub / Ubc HD02 CP95 value	FLOAT	%/x100	
25268	RO	Ub / Ubc HD02 CP99 value	FLOAT	%/x100	
25270	RO	Uc / Uca HD02 CP95 value	FLOAT	%/x100	
25272	RO	Uc / Uca HD02 CP99 value	FLOAT	%/x100	
...	RO	...	FLOAT	%/x100	
25838	RO	Ua / Uab 50 th harmonic CP95 value	FLOAT	%/x100	
25840	RO	Ua / Uab 50 th harmonic CP99 value	FLOAT	%/x100	
25842	RO	Ub / Ubc 50 th harmonic CP95 value	FLOAT	%/x100	
25844	RO	Ub / Ubc 50 th harmonic CP99 value	FLOAT	%/x100	
25846	RO	Uc / Uca 50 th harmonic CP95 value	FLOAT	%/x100	
25848	RO	Uc / Uca 50 th harmonic CP99 value	FLOAT	%/x100	
25850	RO	Ia TDD CP95 value	FLOAT	%/x100	
25852	RO	Ia TDD CP99 value	FLOAT	%/x100	
25854	RO	Ib TDD CP95 value	FLOAT	%/x100	
25856	RO	Ib TDD CP99 value	FLOAT	%/x100	
25858	RO	Ic TDD CP95 value	FLOAT	%/x100	
25860	RO	Ic TDD CP99 value	FLOAT	%/x100	
25862	RO	Ia TDD Odd CP95 value	FLOAT	%/x100	
25864	RO	Ia TDD Odd CP99 value	FLOAT	%/x100	
25866	RO	Ib TDD Odd CP95 value	FLOAT	%/x100	
25868	RO	Ib TDD Odd CP99 value	FLOAT	%/x100	
25870	RO	Ic TDD Odd CP95 value	FLOAT	%/x100	
25872	RO	Ic TDD Odd CP99 value	FLOAT	%/x100	
25874	RO	Ia TDD Even CP95 value	FLOAT	%/x100	
25876	RO	Ia TDD Even CP99 value	FLOAT	%/x100	
25878	RO	Ib TDD Even CP95 value	FLOAT	%/x100	
25880	RO	Ib TDD Even CP99 value	FLOAT	%/x100	
25882	RO	Ic TDD Even CP95 value	FLOAT	%/x100	
25884	RO	Ic TDD Even CP99 value	FLOAT	%/x100	
25886	RO	Ia DD02 CP95 value	FLOAT	%/x100	
25888	RO	Ia DD02 CP99 value	FLOAT	%/x100	

26890	RO	Ib DD02 CP95 value	FLOAT	%/x100	
25892	RO	Ib DD02 CP99 value	FLOAT	%/x100	
25894	RO	Ic DD02 CP95 value	FLOAT	%/x100	
25896	RO	Ic DD02 CP99 value	FLOAT	%/x100	
...	RO	...	FLOAT	%/x100	
26462	RO	Ia DD50 CP95 value	FLOAT	%/x100	
26464	RO	Ia DD50 CP99 value	FLOAT	%/x100	
26466	RO	Ib DD50 CP95 value	FLOAT	%/x100	
26468	RO	Ib DD50 CP99 value	FLOAT	%/x100	
26470	RO	Ic DD50 CP95 value	FLOAT	%/x100	
26472	RO	Ic DD50 CP99 value	FLOAT	%/x100	

Table 5-67 IEEE Std 519-2022 Report

Note:

1. The following table illustrates the Data Structure of the Start/End Time.

Offset	Property	Description	Format	Unit
+0	RO	Year	UINT16	0-37 (Year-2000)
	RO	Month		1 to 12
+1	RO	Day	UINT16	1 to 31
	RO	Hour		0 to 23
+2	RO	Minute	UINT16	0 to 59
	RO	Second		0 to 59

Table 5-68 Time Structure

- The IEEE Std 519-2022 compliance report provides Daily CP99, Weekly CP95 and Weekly CP99 values. When Log Type is set to Daily, the corresponding registers for CP95 are invalid.
- When the Wiring Mode is 3P3W, the percentile values for the UIn harmonic distortion and individual harmonics mean the Ull harmonic distortion and individual harmonics.

5.16.10 TOU Log

5.16.10.1 Present TOU Status

Register	Property	Description	Format	Note/Range
36000	RO	Present Tariff Schedule	UINT16	0~7: T1~T8
36001	RO	Present Season Schedule	UINT16	0~11: Season 1~12
36002	RO	Present Daily Profile	UINT16	0~11: Daily Profile 1~12
36003	RO	Present Daily Profile Index	UINT16	0~19: Daily Profile Index 1~20
36004	RO	Present Weekday Type	UINT16	0=Weekday 1, 1=Weekday 2 2=Weekday 3, 3=Special Day
36005	RO	Present TOU Schedule	UINT16	0~1
36006	RO	TOU Log Pointer	UINT32	

Table 5-69 TOU Real-time Status

5.16.10.2 Real-time TOU Log

Register	Description	Format
36100~36139	Tariff #1 Data	See Section 5.16.10.5
36140~36179	Tariff #2 Data	
36180~36219	Tariff #3 Data	
36220~36259	Tariff #4 Data	
36260~36299	Tariff #5 Data	
36300~36339	Tariff #6 Data	
36340~36379	Tariff #7 Data	
36380~36419	Tariff #8 Data	

Table 5-70 TOU Real-time Log

5.16.10.3 TOU Historical Log

The iMeter 7A can store up to 12 months of TOU Historical Log. Retrieve the newest 12 entries of TOU logs by writing the entry number which you can get from **Historical TOU Data Record Pointer** (Register 0251) into **Log Index X** (Register 36500). For example, if the value for the **Historical TOU Data Record Pointer** is 100, then you can write 100 to 89 into the **36500** register where 100 means the newest logs, and 89 means the oldest logs.

Register	Property	Description	Format
36500	RW	Log Index N	UINT32
36502	RO	Record Time	UINT16
36505	RO	Period PF Avg. (Avg. PF over the Period)	FLOAT
36507~36546	RO	Tariff #1 Data	See Section 5.16.10.5
36547~36586	RO	Tariff #2 Data	
36587~36626	RO	Tariff #3 Data	
36627~36666	RO	Tariff #4 Data	
36667~36706	RO	Tariff #5 Data	
36707~36746	RO	Tariff #6 Data	
36747~36786	RO	Tariff #7 Data	
36787~36826	RO	Tariff #8 Data	

Table 5-71 TOU Historical Log

5.16.10.4 TOU Freeze Log

Register	Property	Description	Format
36900	RO	Record Time	UINT16
36903~36942	RO	Tariff #1 Data	See Section 5.16.10.5
36943~36982	RO	Tariff #2 Data	
36983~37022	RO	Tariff #3 Data	
37023~37062	RO	Tariff #4 Data	
37063~37102	RO	Tariff #5 Data	
37103~37142	RO	Tariff #6 Data	
37143~37182	RO	Tariff #7 Data	
37183~37222	RO	Tariff #8 Data	

Table 5-72 TOU Freeze Log

5.16.10.5 TOU Log Data Structure

Offset	Property	Description	Format
+0	RW	kWh Import	INT64
+4	RW	kWh Export	INT64
+8	RW	kvarh Import	INT64
+12	RW	kvarh Export	INT64
+16	RW	kVAh	INT64
+20	RO	P Import Max. Demand	FLOAT
+22~+24	RO	P Import Max. Demand Timestamp ¹	UINT16
+25	RO	P Export Max. Demand	FLOAT
+27~+29	RO	P Export Max. Demand Timestamp ¹	UINT16
+30	RO	Q Import Max. Demand	FLOAT
+32~+34	RO	Q Import Max. Demand Timestamp ¹	UINT16
+35	RO	Q Export Max. Demand	FLOAT
+37~+39	RO	Q Export Max. Demand Timestamp ¹	UINT16

Table 5-73 TOU Log Data Structure

Notes:

- 1) The following table illustrates the register of timestamps:
- 2) The TOU Demand Logs with their timestamps should be read in one transaction. For example, read the start register 36120 with an offset of 5 registers to retrieve the Real-time TOU Demand Log in one transmission.

Offset	Description
+0	High: Year (-2000)
	Low: Month
+1	High: Day
	Low: Hour
+2	High: Minute
	Low: Second

Table 5-74 Timestamp Format

5.17 Device Setting

5.17.1 iTrigger Setting

Register	Property	Description	Format	Range/Option, Default*
38000	RW	iTrigger Enable	UINT16	0=Disabled*, 1=Enabled
38001	RW	GOOSE VLAN ID	UINT16	0 ~ 4095, 1*
38002	RW	Group ID	UINT16	0 ~ 16383, 1*
38003	RW	iTrigger Group 1	INT16	-1* ~ 16383, (-1 represents Cross-Group Trigger disabled)
38004	RW	iTrigger Group 2	INT16	
38005	RW	iTrigger Group 3	INT16	
38006	RW	iTrigger 1 Actions	BITMAP	See Note 1, 0x8000000* (DWR)
38008	RW	iTrigger 2 Actions	BITMAP	See Note 1, 0x10000000* (WFR)
38010	RW	iTrigger 3 Actions	BITMAP	See Note 1, 0x20000000* (RMSR)
38012	RW	Version	UINT16	0=V1*, 1=V2
38013	RW	GOOSE Enable	BITMAP	BIT0=GOOSE Enable (0*) BIT1=Multicast (0*) BIT2= Multicast Receive (0*) BIT3=Multicast Send (0*) 0=Disabled, 1=Enabled
38014	RW	Multicast IP	UINT32	0xE0000100 ~ 0xEFFFFFFF, 0xEF060708 (239.6.7.8)*
38016	RW	Multicast Send Port	UINT16	0 ~ 65535, 60000*
38017	RW	Multicast Received Port	UINT16	0 ~ 65535, 60001*
38018	RW	P1 Mode for iTrigger Message	UINT16	0=Forbidden, 1=Receive only, 2=Transmit only, 3=Receive and Transmit*
38019	RW	P2 Mode for iTrigger Message	UINT16	

Table 5-75 iTrigger Setting

Note:

- The following table illustrates the details of the **Trigger Actions** register with a bit value of “1” meaning Active while “0” meaning Inactive.

BIT	Trigger	BIT	Trigger	BIT	Trigger
0	Alarm	4	DO4 Closed	29	RMSR
1	DO1 Closed	5~26	Reserved	30~31	Reserved
2	DO2 Closed	27	DWR		
3	DO3 Closed	28	WFR		

Table 5-76 iTrigger Trigger Actions

5.17.2 VPN Setting

Register	Property	Description	Format	Range/Option, Default*
39000	RW	Operating Mode	UINT16	0=Disabled*, 1=Terminal, 2=Gateway
39001	RW	Start Mode	UINT16	0=Auto, 1=Flow Activated, 2=Manual*
39002	RW	Exchange Mode	UINT16	0=Main, 1=Aggressive*
39003~39052	RW	Peer Address	CHAR	Null* (should not exceed 100 characters)
39053~39102	RW	Local Subnet	CHAR	Null* (should not exceed 100 characters, Consists of IP Address and Subnet Mask)
39103~39152	RW	Remote Subnet	CHAR	
39153	RW	IKE Proposal	UINT16	See Note 1, 0*
39154	RW	IKE Lifetime	UINT32	60~86400 (s), 28800*
39156~39205	RW	Local Identity	CHAR	Null* (should not exceed 100 characters)
39206~39255	RW	Remote Identity	CHAR	
39256	RW	Authentication Mode	UINT16	0=Pre-shared Key*, 1=RSA Signature
39257~39306	RW	Key ²	CHAR	Null* (should not exceed 100 characters)
39307	RW	ESP Encryption, Authentication and Key Exchange Proposal	UINT16	See Note 1, 0*
39308	RW	AH Authentication and Key Exchange Proposal	UINT16	See Note 3, 0*
39309	RW	IPsec Lifetime	UINT32	60~86400 (s), 28800*
39311	RW	IPsec Security Protocol	UINT16	0=ESP*, 1=AH
39312	RW	IKE Version	UINT16	0=IKE, 1=IKE V1*, 2=IKE V2
39313	RW	Local Identity Mode	UINT16	0=IP*, 1=User FQDN, 2=FQDN
39314	RW	Remote Identity Mode	UINT16	
39315	RW	PING Interval	UINT32	0~86400 (s), 0*
39317	RW	Reconnection Interval	UINT32	
39319~39368	RW	PING Target Address	CHAR	Null* (should not exceed 100 characters)

Table 5-77 VPN Setting

Notes:

- The iMeter 7A supports the following Encryption, Authentication and Key Exchange proposal.

ID	Proposal	ID	Proposal	ID	Proposal
0	3DES_MD5_DH1	6	AES_MD5_DH1	12	DES_MD5_DH1
1	3DES_MD5_DH2	7	AES_MD5_DH2	13	DES_MD5_DH2
2	3DES_MD5_DH5	8	AES_MD5_DH5	14	DES_MD5_DH5
3	3DES_SHA1_DH1	9	AES_SHA1_DH1	15	DES_SHA1_DH1
4	3DES_SHA1_DH2	10	AES_SHA1_DH2	16	DES_SHA1_DH2
5	3DES_SHA1_DH5	11	AES_SHA1_DH5	17	DES_SHA1_DH5

Table 5-78 Encryption, Authentication and Key Exchange Proposal

- The Key is valid only when the Authentication Mode is set to Pre-shared Key.
- The iMeter 7A supports the following AH Authentication and Key Exchange Proposal.

ID	Proposal	ID	Proposal	ID	Proposal
0	MD5_DH1	2	MD5_DH5	4	SHA1_DH2
1	MD5_DH2	3	SHA1_DH1	5	SHA1_DH5

Table 5-79 AH Authentication and Key Exchange Proposal

5.17.3 Communication Setting

Register	Property	Description	Format	Range/Option, Default*
40000	RW	RS-485 Port Unit ID	UINT16	1~247, 100*
40001	RW	RS-485 Port Baud Rate	UINT16	0=1200, 1=2400, 3=9600*, 4=19200, 5=38400
40002	RW	RS-485 Port Parity	UINT16	0=None, 1=Odd, 2=Even*
40003	RW	RS-485 Port Stop Bit	UINT16	1=1*, 2=2
40004	RW	RS-485 Port Protocol	UINT16	0=Modbus*, 1=Ethernet Gateway, 2=Disabled
40005	RW	Ethernet Gateway Port	UINT16	20000~60000, 20000*
40006~40013	--	Reserved	--	
40014	RW	Firewall Packet Rate Limit~	UINT32	1000~5000 pps, 2200*
40016	RW	IP Address 1	UINT32	0xC0A80064 (192.168.0.100)
40018	RW	Subnet Mask 1	UINT32	0xFFFFFFFF (255.255.255.0)
40020	RW	Default Gateway	UINT32	0xC0A80001 (192.168.0.1)
40022	RW	IP Address 2	UINT32	0xC0A80164 (192.168.1.100)
40024	RW	Subnet Mask 2	UINT32	0xFFFFFFFF (255.255.255.0)
40026	RW	Preferred DNS	UINT32	0x8080808 (8.8.8.8)
40028	RW	Alternative DNS	UINT32	0x72727272 (114.114.114.114)
40030	RW	Network Mode~	UINT16	1=Switch, may cause network storms 2=Normal, prevents network storms* 3=RSTP, eliminates the loop
40031	--	Reserved	--	
40032	RW	White List Control	UINT16	0=Disabled*, 1=Enabled
40033	RW	White List IP1	UINT32	0*
40035	RW	White List IP2	UINT32	0*
...	RW	...	UINT32	0*
40063	RW	White List IP16	UINT32	0*
40065	RW	NTP Server	UINT32	0*
40067~40068	--	Reserved	--	
40069	RW	Bridge Priority ¹	UINT16	0~15, 8*
40070	RW	Hello Time ^{1~}	UINT16	BPDU (Bridge Protocol Data Unit) Packet Transmission Interval 1~10s, 2*
40071	RW	Max Age ^{1~}	UINT16	6~40s, 20*
40072	RW	Forward Delay ^{1~}	UINT16	4~30s, 15*
40073	RW	Port1 Path Cost ^{1,2~}	UINT32	0*~200,000 0 indicates auto-negotiation for the path cost from the bridge to the root.
40075	RW	Port1 Priority ^{1,2~}	UINT16	0~15, 8*
40076	RW	Port2 Path Cost ^{1,2~}	UINT32	0*~200,000
40078	RW	Port2 Priority ^{1,2~}	UINT16	0~15, 8*

~ Available in Firmware V2.50.08 or later

Table 5-80 Communication Setting

Notes:

- 1) The RSTP parameters are valid when the **Network Mode** is set to **RSTP** and must satisfy: $2 \times (\text{Forward Delay} - 1 \text{ s}) \geq \text{Max Age} \geq 2 \times (\text{Hello Time} + 1 \text{ s})$
- 2) **Port x Priority** means the priority of the bridge in the network. A lower value indicates a higher priority.
Actual Priority = Configured Value \times 16

5.17.4 DI Setting

Register	Property	Description	Format	Range/Option, Default*
40100	RW	DI1 Mode	UINT16	0=Status Input*, 1=Pulse Counter, 2=DMD Sync., 3=Tariff Switch
40101	RW	DI1 Debounce	UINT16	1 to 9999 (ms), 20ms*
40102	RW	DI1 Pulse Weight	UINT32	1*~1,000,000
40104	RW	DI1 Setpoint Type ²	UINT16	0=Any Edge*, 1=Positive, 2=Negative
40105	RW	DI1 Setpoint Trigger	BITMAP	0*
40106~40108	--	Reserved	--	
...		...	UINT16	...
40163	RW	DI8 Mode ¹	UINT16	0=Status Input*, 1=Pulse Counter, 2=DMD Sync
40164	RW	DI8 Debounce	UINT16	1 to 9999 (ms), 20ms*
40165	RW	DI8 Pulse Weight	UINT32	1*~1,000,000
40167	RW	DI8 Setpoint Type ²	UINT16	0=Any Edge*, 1=Positive, 2=Negative
40168	RW	DI8 Setpoint Trigger	BITMAP	0*

Table 5-81 DI Setting

Notes:

1. Only one DI should be programmed as the **DMD Sync.** To use a different DI for DMD Sync., the existing DI must first be reset to **Status Input** before programming the new DI for **DMD Sync.**, otherwise the configuration will be unsuccessful.
Only DI1 to DI3 can be set as **Tariff Switch**.
2. The DIx Setpoint Type only affects which edge would trigger the Waveform Recorder, and RMS Recorder, if configured.
3. The table below provides a list of DIx's Setpoint Trigger, with a value of "1" meaning Active and "0" meaning Inactive.

BIT	Action	BIT	Action	BIT	Action	BIT	Action
0	Alarm Output Closed	15	DR #1	21	DR #7	27	DWR
1	DO1 Closed	16	DR #2	22	DR #8	28	WFR
2	DO2 Closed	17	DR #3	23	Reserved	29	RMSR
3	DO3 Closed	18	DR #4	24	iTrigger 1		
4	DO4 Closed	19	DR #5	25	iTrigger 2		
5~14	Reserved	20	DR #6	26	iTrigger 3		

Table 5-82 DIx's Setpoint Triggers

5.17.5 DO Setting

Register	Property	Description	Format	Range/Option, Default*
40300	RW	LOP Alarm Enable	UINT16	0=No, 1=Yes*
40301	RW	Arm Before Execute	UINT16	0=Enabled*, 1=Disabled
40302	RW	Alarm Pulse Width	UINT16	0* (Latch Mode) to 6000 (x0.1s)
40303	RW	DO1 Pulse Width	UINT16	
40304	RW	DO2 Pulse Width	UINT16	
40305	RW	DO3 Pulse Width	UINT16	
40306	RW	DO4 Pulse Width	UINT16	

Table 5-83 DO Setting

Notes:

1. If the Alarm Output isn't programmed as LOP (Loss-of-Power) alarm, it can be used as a normal relay.
2. The **Arm Before Execute** setup register is used to specify if the relays need to be armed before they can be operated on.
3. **DO Pulse Width** specifies the duration for which the relay output will be active when a Remote Operate or Setpoint Trigger command is received to operate it.

5.17.6 AI Setting

Register	Property	Description	Format	Range/Option, Default*
40400	RW	AI1 Type	UINT16	0=4~20mA*, 1=0~20mA
40401	RW	AI1 Zero Scale	INT32	-999,999 to +999,999, 400*
40403	RW	AI1 Full Scale	INT32	-999,999 to +999,999, 2000*
40405	RW	AI2 Type	UINT16	0=4~20mA*, 1=0~20mA
40406	RW	AI2 Zero Scale	INT32	-999,999 to +999,999, 400*
40408	RW	AI2 Full Scale	INT32	-999,999 to +999,999, 2000*

Table 5-84 AI Setting

5.17.7 Cloud Setting

Register	Property	Description	Format	Range/Option, Default*
40430	RW	Cloud Access Enable	UINT16	0=No*, 1=Yes
40431	RW	Encryption	UINT16	0=Disabled, 1=Enabled*
40432	--	Reserved	--	
40434	RW	Service Port	UINT16	1-65535, 38084*
40435	RW	Upload Interval	UINT32	3~7200 (s), 10*
40437	RW	Basic Measurement _push type	BITMAP	See Note 1, 0*
40439	RW	Harmonics Data _push type	BITMAP	
40441	RW	Interharmonics Data _push type	BITMAP	
40443	RW	2k-150kHz C.E. Data _push type	BITMAP	
40445	RW	Log _push type	BITMAP	See Note 2, 0*
40447	RW	File Upload Port	UINT16	1~65535, 30080*
40448~40479	RW	Cloud Server Address	CHAR	Null*

Table 5-85 Cloud Setting

Notes:

1. Select the following real-time measurement type to be uploaded to the Cloud with “1” meaning selected.

BIT	Basic Measurement	Harmonics Data	Interharmonics Data	2k-150kHz C.E.
BIT0	RMS	Ia HD	Ia IHD	Phase A C.E. RMS
BIT1	Fundamental	Ib HD	Ib IHD	Phase B C.E. RMS
BIT2	Energy	Ic HD	Ic IHD	Phase C C.E. RMS
BIT3	Harmonic Energy	I4 HD	I4 IHD	Reserved
BIT4	Individual Harmonic Energy	Reserved	Ia TIH RMS	Reserved
BIT5	Demand	Ia TH RMS	Ib TIH RMS	Reserved
BIT6	TOU	Ib TH RMS	Ic TIH RMS	Reserved
BIT7	I/O	Ic TH RMS	I4 TIH RMS	Reserved
BIT8	Real-time Waveform	I4 TH RMS	Ua/Uab IHD	Reserved
BIT9	This Max Demand	Reserved	Ub/Ubc IHD	Reserved
BIT10	Max	Ua/Uab HD	Uc/Uca IHD	Reserved
BIT11	Min	Ub/Ubc HD	U4 IHD	Reserved
BIT12	Reserved	Uc/Uca HD	Ua/Uab TIH RMS	Reserved
BIT13	Reserved	U4 HD	Ub/Ubc TIH RMS	Reserved
BIT14	Reserved	Reserved	Uc/Uca TIH RMS	Reserved
BIT15	Reserved	Ua/Uab TH RMS	U4 TIH RMS	Reserved
BIT16	Reserved	Ub/Ubc TH RMS	Reserved	Reserved
BIT17	Reserved	Uc/Uca TH RMS	Reserved	Reserved
BIT18	Reserved	U4 TH RMS	Reserved	Reserved
BIT19	Reserved	Reserved	Reserved	Reserved
BIT20	Power Quality	P Total TH	Reserved	Reserved
BIT21	Reserved	Pa TH	Reserved	Reserved
BIT22	Reserved	Pb TH	Reserved	Reserved
BIT23	Reserved	Pc TH	Reserved	Reserved

Table 5-86 Real-time Measurement Push Type

2. Select the following log type to be uploaded to the DiagSys Cloud with “1” meaning selected.

BIT	Log Type	BIT	Log Type
BIT0	Device Log	BIT9	Last Min. Log
BIT1	SOE Log	BIT10	Pst Log
BIT2	Reserved	BIT11	Plt Log
BIT3	Statistical Data Log	BIT12	EN 50160 Report
BIT4	Interval Energy Log	BIT13	2k-150kHz C.E. Log
BIT5	Accumulative Energy Log	BIT14	Waveform Log
BIT6	Historical TOU Log	BIT15	Disturbance Waveform Log
BIT7	Last Max. Demand Log	BIT16	RMS Log
BIT8	Last Max. Log		

Table 5-87 Log Push Type

5.17.8 Algorithm Setting

Register	Property	Description	Format	Range/Option, Default*
40580	RW	PF Convention	UINT16	0=IEC*, 1=IEEE, 2=-IEEE
40581	RW	kVA Calculation	UINT16	0=Vector*, 1=Standard
40582	RW	HD Calculation	UINT16	0=% of FUND*, 1=% of RMS, 2=% of Vnom
40583	RW	Harmonic Calculation Method	UINT16	0=Subgroup*, 1=Group
40584	RW	THD Order	UINT16	2~63, 63*
40585	RW	Flicker Curve	UINT16	0=120V, 1=230V*

Table 5-88 Algorithm Setting

Notes:

1. PF Convention: -IEEE is the same as IEC but with the opposite sign.

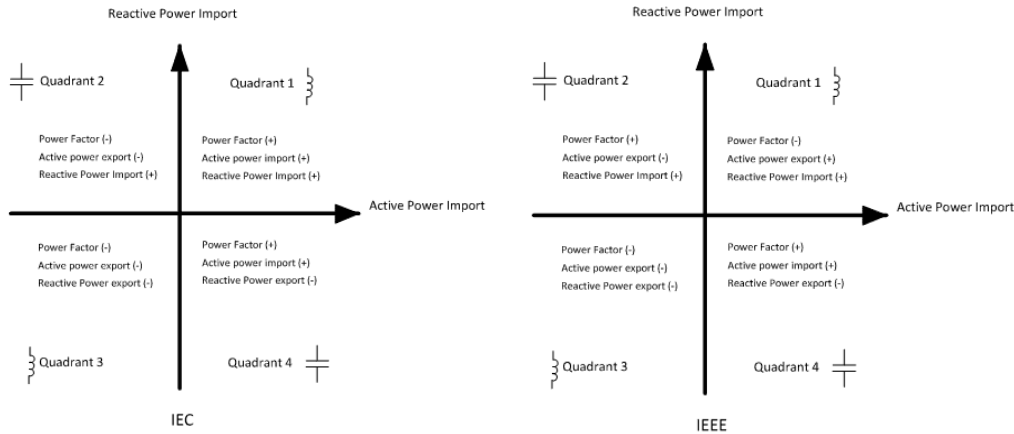

Figure 5-1 PF Convention

2. There are two ways to calculate kVA:

Mode V (Vector method): $kVA_{total}^2 = \sqrt{kW_{total}^2 + kvar_{total}^2}$
Mode S (Scalar method): $kVA_{total} = kVA_a + kVA_b + kVA_c$

5.17.9 Other Setting

Register	Property	Description	Format	Range/Option, Default*
40751	RW	D/S RMS Update ¹	UINT16	0=1/2-cycle*, 1=1-cycle
40752	RW	Interruption Mode ²	UINT16	0=Single Phase, 1=Three Phase*
40753	--	Reserved	--	
40754	RW	D/S Max. Duration	UINT16	1~600 (s), 60*
40755	RW	Swell Max. Duration	UINT16	101~500 (%), 500*
40756	RW	TC1 Compensation Resistance	UINT16	(x100), 55*
40757	RW	TC2 Compensation Resistance	UINT16	(x100), 55*
40758	RW	Energy Short Rollover	UINT16	0=Disabled*, 1=Enabled
40759	RW	PTP Enable	UINT16	0=Disabled, 1=P1, 2=P2, 3=P1 & P2
40760	RW	PTP Protocol	UINT16	0=PTP over UDP*, 1=PTP over 802.3
40761	RW	PTP Domain	UINT16	0~127, 0*
40762	RW	PTP Priority 1	UINT16	0~255, 255*
40763	RW	PTP Priority 2	UINT16	0~255, 255*
40764~40779	RW	SMTP Server	CHAR	Null* (Less than 32 characters)
40780~40787	RW	SNMP Read-only Password	CHAR	public* (Less than 16 characters)
40788~40795	RW	SNMP Read & Write Password	CHAR	private* (Less than 16 characters)
40796	RW	Enable FTPS SSL/TLS	UINT16	0=No*, 1=Yes
40797	RW	Enable HTTP SSL/TLS	UINT16	0=No*, 1=Yes
40798	--	Reserved	--	
40799	RW	Delimiter ³	UINT16	0=Option 1*, 1=Option 2
40800	--	Reserved	--	
40801	RW	Time Zone	UINT16	0~32 (See Note 4), 26*
40802	RW	IRIG-B Time Zone	UINT16	0~32 (See Note 4), 26*
40803	RW	Language	UINT16	0=English*, 1=Chinese 2~9=Map by language pack import order
40804	RW	Date Format	UINT16	0=YYYY/MM/DD*, 1=MM/DD/YYYY 2=DD/MM/YYYY, 3=YYYY-MM-DD 4=MM-DD-YYYY, 5=DD-MMM-YYYY
40805	--	Reserved	--	
40806	RW	LCD Timeout	UINT16	0~60 (min), 5*
40807	RW	LCD Backlight	UINT16	50~100 (%), 90*
40808	RW	Phase A Color	UINT16	0~13 (See Note 5), 1*
40809	RW	Phase B Color	UINT16	0~13 (See Note 5), 4*
40810	RW	Phase C Color	UINT16	0~13 (See Note 5), 8*
40811	RW	Phase N Color	UINT16	0~13 (See Note 5), 13*
40812	RW	GND Color	UINT16	0=Green, 1=Yellow-Green striped*
40813	RW	Front Panel Password	UINT32	000000~999999, 000001*
40815	--	Reserved	--	
40817	RW	Flagged Data Trigger Setpoint ⁶	UINT32	0=Yes, 1=No*
40819	RW	Modbus/COMTRADE Time	BITMAP	0~15 (See Note 7), 0*

		Format		
40820	RW	Enable SNMP	UINT16	0=No*, 1=Yes
40821	RW	SNMP Port	UINT16	1~65535, 161*
40822~40823	--	Reserved	--	
40824	RW	No. of Sampling Rates (COMTRADE)	UINT16	0~1 (See Note 8), 0*
40825	RW	Eliminate Flagged Data	BITMAP	0~63 (See Note 9), 0*
40826~40842	--	Reserved	--	
40843	RW	Enable FTPS	UINT16	0=No, 1=Yes*
40844~40847	--	Reserved	--	
40848	RW	Flicker Convention	UINT16	0=IEC*, 1=Improved IEC
40849~40856	--	Reserved	--	
40857	RW	Enable Web/DiagSys/HTTP	UINT16	0=No, 1=Yes*
40858	RW	Enable Web Client Validate	UINT16	0=No*, 1=Yes
40859	RW	HTTP Port	UINT16	1~65535, 80*
40860	RW	HTTPS Port	UINT16	1~65535, 443*
40861	RW	FTPS Port	UINT16	1~65535, 21*
40862~40863	--	Reserved	--	
40864	RW	Enable Modbus TCP	UINT16	0=No, 1=Yes*
40865	RW	Modbus TCP Port	UINT16	1~65535, 502*
40866	RW	Enable HMI Security	UINT16	0=No*, 1=Yes
40867	RW	Enable IEC 61850 ¹⁰	UINT16	0=No, 1=Yes*
40868	RW	Enable P1	UINT16	0=No, 1=Manual*, 2=DHCP
40869	RW	Enable P2	UINT16	
40870	RW	Modbus TCP Unit ID	UINT16	1~247, 100*
40871	--	Reserved	--	
40872	RW	Enable SMTP SSL/TLS	UINT16	0=No*, 1=Yes
40873	RW	IEC 61850 Debug Setting	UINT16	0=Disable*, 1=Enable
40874	RW	IEC 61850 Debug Message Export	UINT16	0=Disable, 1=To File*, 2=To Debug Port
40875	RW	IEC 61850 Debug Message Class	UINT16	0=Serious Error, 1=System Error, 2=Program Error, 3=Key Info., 4=Information, 5=Debug Info.
40876	RW	IEC 61850 Quality Validity	UINT16	0=Disabled*, 1=Domestic, 2=IBD
40877	RW	IEC 61850 Authentication	UINT16	0=Disable*, 1=Enable
40878~40886	RW	IEC 61850 Security Key	CHAR	Default=abcd01234567\$%^& (Must be 16 characters)
40887~40893	RW	IEC 61850 Password	CHAR	01+SN* (Up to 12 characters)
40894	RW	IEC 61850 Timestamp Offset	UINT16	0* (s), "0" means the time difference is not examined
40895	RW	COMTRADE Stored Value Type	UINT16	0=Secondary, 1=Primary*
40896	RW	Web Login Timeout	UINT16	0~1440 (min), 5*
40897	RW	IEC 61850 Port ¹⁰	UINT16	1~65535, 102*

Table 5-89 Other Setting

Notes:

- The **Dip/Swell RMS Update** register determines if the Urms is computed every cycle and then shifted by ½ cycle (register value = 0) or if the Urms is computed every ½ cycle and then shifted by ½ cycle (register value = 1).
- The **Interruption Mode** register determines if an Interruption event should start when the Urms of all 3 phases (register value = 1) or when the Urms of any phase (register value = 0) are lower than the Interruption Threshold.
- The **Delimiter** setup register supports two options, 1 and 2:
 Option 1: “.” is used as the x1000 delimiter and “.” as the decimal point (e.g. 123,456,789.0).
 Option 2: “ ” is used as the x1000 delimiter and “.” as the decimal point (e.g. 123 456 789,0).
- The **IRIG-B Time Zone** setting is valid only when the iMeter 7A is connected to an IRIG-B signal output. The following table lists the Codes for different Time Zones.

Code	Time Zone	Code	Time Zone	Code	Time Zone
0	GMT-12:00	11	GMT-2:00	22	GMT+5:45
1	GMT-11:00	12	GMT-1:00	23	GMT+6:00
2	GMT-10:00	13	GMT-0:00	24	GMT+6:30
3	GMT-9:00	14	GMT+1:00	25	GMT+7:00
4	GMT-8:00	15	GMT+2:00	26	GMT+8:00
5	GMT-7:00	16	GMT+3:00	27	GMT+9:00
6	GMT-6:00	17	GMT+3:30	28	GMT+9:30
7	GMT-5:00	18	GMT+4:00	29	GMT+10:00
8	GMT-4:00	19	GMT+4:30	30	GMT+11:00
9	GMT-3:30	20	GMT+5:00	31	GMT+12:00
10	GMT-3:00	21	GMT+5:30	32	GMT+13:00

Table 5-90 Time Zone Codes

5. The following table lists the color options for different wires.

No.	Color (R, G, B)	No.	Color (R, G, B)	No.	Color (R, G, B)
0	Brown (153,51,0)	5	Turquoise (0,162,132)	10	Grey (159,159,159)
1	Red (255,0,0)	6	Green (0,255,36)	11	Neutral Grey (193,193,193)
2	Pink (255,173,177)	7	Light blue (79,204,246)	12	White (255,255,255)
3	Orange (255,102,0)	8	Blue (0,0,255)	13	Black (0,0,0)
4	Yellow (255,216,0)	9	Violet (112,48,160)		

Table 5-91 Wire Color Options

6. A value of “1” for Flagged Data Trigger Setpoint means the following behavior exist
- When the Setpoint (including PQ Setpoint, Control Setpoint and etc.) or Alarm (ITIC Alarm, SEMI F47 Alarm and etc.) Active Limit is reached, the Setpoint/Alarm couldn’t be activated due to the triggered value containing flagged data.
 - Once the iMeter 7A is powered on, all the measurements will be flagged and the Setpoint/Alarm are blocked until the voltage measured exceeds the Dip Limit but beyond the Swell Limit.
7. The timestamp for different data is programmable by writing the “Time Format” register, with the bit value of “0” meaning Local Time, while “1” meaning UTC Time. The following table illustrates the details of this register.

BIT	Description	Note
BIT0	MODBUS	Timestamp of retrieved Data logs via Modbus: Real-time measurement, SOE Log, Device Log, SDR, Max./Min. Log, DR, Plt/Pst, EN 50160 Log, TOU Log, IER and AER Log.
BIT1	COMTRADE	Timestamp of COMTRADE file including the first/trigger point in the .cfg file

Table 5-92 Modbus/COMTRADE Time Format

8. “0” means the DWR file in COMTRADE format doesn’t include any sampling section information.
9. For **Eliminate Flagged Data** register, the bit value of “0” means keep the flagged data in the log while “1” means remove the flagged data. The following table illustrates the detail of this register.

Others	BIT5	BIT4	BIT3	BIT2	BIT1	BIT0
Reserved	IEEE Std 519 Log	Reserved	EN 50160 Log	Min. Log	Max. Log	SDR Log

Table 5-93 Eliminate Flagged Data Detail

10. Modification written to this register requires a device reboot to take effect.

5.17.10 SMTP Setting

Register	Property	Description	Format	Range/Option, Default*
40900	RW	SMTP Trigger Event Classification	BITMAP	Note 1), 0*
40902	RW	SMTP Service Port	UINT16	1 to 65535, 25*
40903	RW	Reserved	UINT32	
40905	RW	Source Email Address ²	CHAR	40 characters (including terminator), Null*
40925	RW	Source User Name ³	CHAR	40 characters (including terminator), Null*
40945	RW	Login Password ⁴	CHAR	20 characters (including terminator), Null*
40955	RW	Destination Email Address ⁵	CHAR	90 characters (including terminator), Null*

Table 5-94 SMTP Setting

Notes:

- 1) **SMTP Trigger Event Classification** register determines if a newly generated Device/SOE Log is sent out by email. The following table illustrates the BITMAP definition of this register. When a particular bit is set to 1, its corresponding events will be sent out by email.

BIT	Classification	BIT	Classification
BIT0	Device Log Events (See Appendix B)	BIT8	Inrush Current
BIT1	Setpoint	BIT9	RVC
BIT2	I/O	BIT10	MSV
BIT3	Record (WFR, DWR, RMSR, etc.)	BIT11	Reserved
BIT4	Reserved	BIT12	Motor Start
BIT5	Reserved	BIT13	EN 50160 Report
BIT6	Dip/Swell/Interruption	BIT14-BIT16	Reserved
BIT7	Transient	BIT27	IEEE Std 519 Report

Table 5-95 SMTP Trigger Event Register (40900)

- 2) This string parameter may be up to 40 characters (including the terminator) long and specifies the source email address that appears in the “From” field of the email. For example, if the email address is iMeter 7A@cet-electric.com, set the parameter as “69 4D 65 74 65 72 20 37 41 40 63 65 74 2D 65 6C 65 63 74 72 69 63 2E 63 6F 6D 00 00” where the two zero characters “00 00” at the end of the string are the string terminator.
- 3) This string parameter may be up to 40 characters (including the terminator) long and specifies the “Source Email Username” that appears in the email. For example, if the username is “abc”, set the parameter as “61 62 63 00 00” where the two zero characters “00 00” at the end of the string are the string terminator.
- 4) This string parameter may be up to 20 characters (including terminator) long and specifies the Logon Password to login the “Source Email Address” account. For example, if the password is “iMeter 7A”, set the parameter as “69 4D 65 74 65 72 20 37 41 00 00” where the two zero characters “00 00” at the end of the string are the string terminator.

5) This string parameter may be up to 90 (including terminator) characters long and specifies the receiver email address that appears in the “To” field of the email. For example, if the email address is iMeter.7A@cet-electric.com, so set the registers as “69 4D 65 74 65 72 20 37 41 40 63 65 74 2D 65 6C 65 63 74 72 69 63 2E 63 6F 6D 00 00” where the two zero characters “00 00” at the end of the string are the string terminator. Different receivers should be separated by “;” symbol.

5.17.11 Basic Setting

Register	Property	Description	Format	Range/Option, Default*
41000	RW	Wiring Mode	UINT16	1= 3P4W*, 2=Reserved, 3=3P3W, 4=Demo
41001	RW	PT Primary	UINT32	1 to 1,000,000 (V), 100*
41003	RW	PT Secondary	UINT32	1 to 1500 (V), 100*
41005	RW	CT Primary	UINT32	1 to 30000 (A), 5*
41007	RW	CT Secondary	UINT32	1 to 50 (A), 5*
41009	RW	U4 Primary	UINT32	1 to 1,000,000 (V), 100*
41011	RW	U4 Secondary	UINT32	1 to 1500 (V), 100*
41013	RW	I4 Primary	UINT32	1 to 30000 (A), 5*
41015	RW	I4 Secondary	UINT32	1 to 50 (A), 5*
41017	--	Reserved	--	
41019	--	Reserved	--	
41021	RW	UII Nominal (Secondary)	UINT32	1 to 1500 (V), 415*
41023	RW	I Nominal (Secondary)	UINT32	1 to 10,000 (A), 5*
41025	RW	CT Polarity	BITMAP	Bit0 to Bit3 represent Ia, Ib, Ic and I4 0=Normal*, 1=Reverse
41026	RW	Composite I	UINT16	0= No Composite*, 1=Phase A 2=Phase B, 3=Phase C
41027	RW	U0 Polarity	UINT16	0=Normal*, 1=Reverse
41028	RW	Neutral Connection	UINT16	0=Directly/Small Resistance/Reactance*, 1=Ungrounded/High Resistance, 2=Arc Suppression Coil
41029	--	Reserved	--	
41030	--	Reserved	--	
41031	--	Reserved	--	
41032	RW	Operating Time Threshold	UINT16	1~1000 (x0.001e), 1*
41033	--	Reserved	--	
41034	--	Reserved	--	
41035	RW	SCCP Option	UINT16	0=5A (50A) @10mV/A*, 1=20A@10mV/A, 2=200A@1mV/A, 3=500A @1mV/A, 4=500A(550A) @1mV/A, 5=5kA @0.1mV/A
41036	RW	SCCT Option	UINT16	0=100A/40mA*, 1=200A/40mA, 2=400A/40mA, 3=800A/40mA, 4=1600A/40mA, 5=5A/2mA
41037	RW	TDD Preset IL Primary ^{1, 2}	UINT32	
41039	RW	I4 TDD Preset IL Primary ^{1, 2}	UINT32	0*~30,000A (x0.001A)

Table 5-96 Basic Setting

Notes:

1. For the **TDD Preset IL Pri.** or **I4 TDD Preset IL Pri.**:

- 0: represents to use the TDD calculation method compatible with the standard TDD calc. in IEEE_519
- non-zero value: the unit is A and it is the preset IL for TDD Calculation

Besides, according to the IEEE_519

IL = maximum demand load current (fundamental frequency component) at the PCC (point of common coupling)

2. It is necessary to reboot the device to allow the new changes to **Preset IL** to take effect. The harmonic current distortion limits will be updated accordingly after reboot.

5.17.12 PQ Setting

Register	Property	Description	Format	Range/Option, Default*
41085	RW	Swell Trigger Actions	BITMAP	See Note 1, 0x28000000* (DWR & RMSR)
41087	RW	Swell Triggers DO	UINT16	0=When PQD starts*, 1=When PQD Ends
41088	RW	Dip Trigger Actions	BITMAP	See Note 1, 0x28000000* (DWR & RMSR)
41090	RW	Dip Triggers DO	UINT16	0=When PQD starts, 1=When PQD Ends*
41091	RW	Interruption Trigger Actions	BITMAP	See Note 1, 0x28000000* (DWR & RMSR)
41093	RW	Interruption Triggers DO	UINT16	0=When PQD starts*, 1=When PQD Ends
41094	RW	ITIC Alarm	BITMAP	See Note 1, 0* (Null)
41096	RW	SEMI F47 Alarm	BITMAP	
41098~41099	--	Reserved	--	
41100	RW	Dip/Swell Enable	UINT16	0=No, 1=Yes*
41101	RW	Dip/Swell Voltage Reference	UINT16	0=Udin(Nominal Voltage)* 1=Usr (Sliding Reference Voltage)
41102	RW	Swell Threshold ²	UINT16	101 to 200 (x0.01 Udin/Usr), 110*
41103	RW	Dip Threshold ²	UINT16	1 to 99 (x0.01 Udin/Usr), 90*
41104	RW	Interruption Threshold ²	UINT16	0 to 50 (x0.01 Udin/Usr), 5*
41105	RW	Swell Hysteresis ²	UINT16	1 to 1000 (x0.001 Udin/Usr), 20*
41106	RW	Dip Hysteresis ²	UINT16	
41107	RW	Interruption Hysteresis ²	UINT16	
41108~41112	--	Reserved	--	
41116	RW	Transient Enable	UINT16	0=No, 1=Yes*
41117	RW	Transient Threshold	UINT16	5 to 500 (%), 35*
41118	RW	Transient Trigger	BITMAP	See Note 1, 0x10000000* (WFR)
41120	RW	Inrush Current Enable	UINT16	0=No*, 1=Yes
41121	RW	Inrush Current Threshold	UINT16	10 to 500 (%), 120*
41122	RW	Inrush Current Hysteresis	UINT16	1 to 1000 (0.1% to 100%), 10*
41123	RW	Inrush Current Trigger	BITMAP	See Note 1, 0x10000000* (WFR)
41126	RW	Disturbance Direction Enable	UINT16	0=No, 1=Yes*
41128	RW	RVC Enable	UINT16	0=No*, 1=Yes
41129	RW	RVC Threshold ²	UINT32	2 to 100 (0.2% to 10%Un), 50*
41131	RW	RVC Hysteresis	UINT32	1 to 50 (0.1% to 5%Un), 25*
41133	RW	RVC Trigger	UINT32	See Note 1, 0x20000000* (RMSR)
41135~41153	--	Reserved	--	
41154	RW	MSV #1 Enable	UINT16	0=No*, 1=Yes
41155	RW	MSV #1 Frequency	UINT16	600 to 30000 (x0.1Hz), 10000*
41156	RW	MSV #1 Threshold	UINT16	3 to 1000 (x0.001 Udin/Usr), 50*
41157	RW	MSV #1 Signalling Time	UINT16	1 to 120s, 60*
41158~41159	--	Reserved	--	
41160	RW	MSV #2 Enable	UINT16	0=No*, 1=Yes
41161	RW	MSV #2 Frequency	UINT16	600 to 30000 (x0.1Hz), 20000*
41162	RW	MSV #2 Threshold	UINT16	3 to 1000 (x0.001 Udin/Usr), 50*
41163	RW	MSV #2 Signalling Time	UINT16	1 to 120s, 60*
41164~41165	--	Reserved	--	
41166	RW	MSV #3 Enable	UINT16	0=No*, 1=Yes
41167	RW	MSV #3 Frequency	UINT16	600 to 30000* (x0.1Hz)
41168	RW	MSV #3 Threshold	UINT16	3 to 1000 (x0.001 Udin/Usr), 50*
41169	RW	MSV #3 Signalling Time	UINT16	1 to 120s, 60*
41170~41171	--	Reserved	--	
41172	RW	Motor Start Enable	UINT16	0=No*, 1=Yes
41173	RW	Motor Start I Nom. Sec.	UINT16	1 to 600 (x0.01A), 500*
41174	RW	Motor Start Trigger Actions	BITMAP	See Note 1, 0x30000000* (WFR&RMSR)
41176	RW	Small Grounding Fault Enable	UINT16	0=No*, 1=Yes
41177	RW	U0 Active Limit	UINT16	0~200 (V), 20*
41178	RW	Active Delay	UINT16	0~100 (ms), 40*
41179	RW	PT/CT Reliability Factor	UINT16	0~10 (x0.1), 5*
41180	RW	SGFC Actions	BITMAP	See Note 1, 0x10000000* (WFR)

Table 5-97 PQ Setting

Notes:

1. The following table illustrates the details of the **Trigger Actions** register with a bit value of “1” meaning Active while “0” meaning Inactive.
 - a. For Dip/Swell/Interruption and Inrush Current setpoint, all the triggers are available for Trigger Actions configuration.
 - b. For Transient and RVC setpoint, DR1 to DR8 are not available for Trigger Actions configuration.

c. For SEMI F47/ITIC Alarm, only support to trigger DO and iTrigger actions.

BIT	Trigger	BIT	Trigger	BIT	Trigger
0	Alarm	17	DR #3	25	iTrigger 2
1	DO1 Closed	18	DR #4	26	iTrigger 3
2	DO2 Closed	19	DR #5	27	DWR
3	DO3 Closed	20	DR #6	28	WFR
4	DO4 Closed	21	DR #7	29	RMSR
5-14	Reserved	22	DR #8	30~31	Reserved
15	DR #1	23	Reserved		
16	DR #2	24	iTrigger 1		

Table 5-98 Dip/Swell/Interruption/Inrush Current Trigger Actions

2. The values for the **Dip Threshold**, **Swell Threshold**, **Voltage Interruption Threshold** and **Dip/Swell/Interruption Hysteresis** should be configured to meet the following criteria:
 - a. The **Voltage Interruption Threshold** shall be set below **Dip Threshold**.
 - b. The **Dip/Swell Hysteresis** must be less than the **Dip** and **Swell Threshold**.
 - c. The **RVC Threshold** must be less than the **Dip** and **Swell Thresholds**.
 - d. Regardless of whether Dip/Swell is enabled, the conditions for a, b, and c must be met.

5.17.13 Demand Setting

Register	Property	Description	Format	Range/Option, Default*
41250	RW	Demand Sync. Mode	UINT16	0=SLD*, 1=SYNC DI
41251	RW	Demand Period	UINT16	1 to 60 minutes, 15*
41252	RW	Number of Sliding Windows	UINT16	1* to 15
41253	RW	Self-Read Time ¹	UINT16	Default=0xFFFF(Manual)
41254	RW	Predicated Response	UINT16	70* to 99

Table 5-99 Demand Setup

Notes:

1. The **Self-Read Time** allows the user to specify the time and day of the month for the Max. Demand Self-Read operation. The **Self-Read Time** supports three options:
 - A zero value means that the Self-Read will take place at 00:00 of the first day of each month.
 - A non-zero value means that the Self-Read will take place at a specific time and day based on the formula: Self-Read Time = Day * 100 + Hour where 0 ≤ Hour ≤ 23 and 1 ≤ Day ≤ 28. For example, the value 1512 means that the Self-Read will take place at 12:00 pm on the 15th day of each month.
 - A 0xFFFF value will disable the Self-Read operation and replace it with manual operation. A manual reset will cause the Max. Demand of **This Month** to be transferred to the Max. Demand of **Last Month** and then reset. The terms **This Month** and **Last Month** will become **Since Last Reset** and **Before Last Reset**.

5.17.14 WFR Setting

Register	Property	Description	Format	Range/Option, Default*
41300	RW	Pre-fault Cycles of WFR	UINT16	2 to 16 (cycles), 5*
41301	RW	Post-fault Cycles of WFR	UINT16	2 to 16 (cycles), 5*
41302	RW	Max. No. of Cycles	UINT16	Range of Cycles @ Samples/Cycle, 100* • (40-3200) @ 128 • (40-1600) @ 256 • (40-800) @ 512 • (40-400) @ 1024
41303	RW	Sampling Rates	UINT16	0=128 Samples/Cycles 1=256 Samples/Cycles 2=512 Samples/Cycles* 3=1024 Samples/Cycles
41304	RW	Adaptive WFR ¹	UINT16	0=Enabled, 1=Disabled*
41305	--	Reserved	--	
41306	RW	Pre-fault Cycles of DWR	UINT16	5* to 10 Cycles
41307	RW	Scheduled WFR Enable	UINT16	0=No*, 1=Yes
41308~41310	RW	Scheduled WFR Start Time	UINT16	See Note 2), 00(Y)01(M)01(D), 00:00:00*
41311	RW	Scheduled WFR Interval	UINT16	1 to 65535 (minutes), 1440*
41312	RW	Repetitions	UINT16	0 to 10000, 1* 0 indicates scheduled WFR feature disabled
41313	RW	Pre-fault Samples of RMSR	UINT16	100 to 500 samples, 300*
41314	RW	RMSR Sampling Interval	UINT16	0* to 60 cycles (0=1/2 cycle)
41315	RW	Channel 1	UINT16	See Note 3), 4 (Uab)*

41316	RW	Channel 2	UINT16	See Note 3), 5 (Ubc)*
41317	RW	Channel 3	UINT16	See Note 3), 6 (Uca)*
41318	RW	Channel 4	UINT16	See Note 3), 7 (Ia)*
41319	RW	Channel 5	UINT16	See Note 3), 8 (Ib)*
41320	RW	Channel 6	UINT16	See Note 3), 9 (Ic)*
41321	RW	Channel 7	UINT16	See Note 3), 12 (Frequency)*
41322	RW	Channel 8	UINT16	See Note 3), 13 (Frequency Deviation)*
41323	RW	Channel 9	UINT16	See Note 3), 1 (Ua)*
41324	RW	Channel 10	UINT16	See Note 3), 2 (Ub)*
41325	RW	Channel 11	UINT16	See Note 3), 3 (Uc)*
41326	RW	Channel 12	UINT16	See Note 3), 0*
41327	RW	Channel 13	UINT16	See Note 3), 0*
41328	RW	Channel 14	UINT16	See Note 3), 0*
41329	RW	Channel 15	UINT16	See Note 3), 0*
41330	RW	Channel 16	UINT16	See Note 3), 0*

Table 5-100 WFR Setting

Notes:

1. **Adaptive WFR** means the length of the Waveform Recording extended as the PQ Disturbance Duration increased until the recording cycle reaches the **Max. No. of Cycles**. If Adaptive WFR is disabled, the Waveform Recording length is fixed to **Max. No. of Cycles** (100 by default).
2. The following table illustrates the **Scheduled WFR Start Time** structure.

Offset	Description
+0	High - Year (-2000) Low - Month
+1	High - Day Low - Hour
+2	High - Minute Low - Second

Table 5-101 Scheduled WFR Start Time Structure

3. The table below lists the available parameters for each channel, please note that the channel should be configured continually from Channel 1.

ID	Parameter	ID	Parameter	ID	Parameter	ID	Parameter
0	Null	9	Ic	18	Qb	27	UII Avg.
1	Ua	10	U4	19	Qc	28	I Avg.
2	Ub	11	I4	20	Sa	29	P Total
3	Uc	12	Frequency	21	Sb	30	Q Total
4	Uab	13	Freq. Dev.	22	Sc	31	S Total
5	Ubc	14	Pa	23	PFa	32	PF Total
6	Uca	15	Pb	24	PFb	33	Fast Freq. (HS Freq.)
7	Ia	16	Pc	25	PFc	34	Reserved
8	Ib	17	Qa	26	UIn Avg.		

Table 5-102 Available RMSR Channel

5.17.15 Energy Pulse Setting

Register	Property	Description	Format	Range/Option, Default*
41350	RW	Energy Pulse Constant ¹	UINT16	0=1000*, 1=3200, 2=5000 3=6400, 4=12800 (imp/kWh)
41351	RW	Energy Pulse Output #1 ²	UINT16	0* to 18
41352	RW	Energy Pulse Output #2 ²	UINT16	0* to 18

Table 5-103 Energy Pulse Setup

Notes:

- 1) It's important to understand that energy pulsing is always based on the secondary ratings (e.g. 100V and 5A) as it would be impossible to generate the required number or pulses based on the primary ratings. The following table illustrates the recommended settings for the **Energy Pulse Constant** based on $Z = V_{nominal} \times I_{nominal} \times 2$, where $V_{nominal}$ and $I_{nominal}$ are the secondary voltage and current nominal ratings, respectively. In general, one would use a higher **Pulse Constant** for a smaller Z value (i.e. a smaller $V_{nominal}$ and $I_{nominal}$) in an accuracy testing situation to reduce the test time.

Z	Energy Pulse Constant	Min. Interval (ms)	Default
≤1000	1000/3200/5000/6400/12800	160	1000
≤2000	1000/3200/5000/6400		
≤2600	1000/3200/5000		
≤4000	1000/3200		
≤13000	1000		

Table 5-104 Energy Pulse Constant Range

2) The following table illustrates the valid options for the Energy Pulse Output setup register:

Value	Source	Value	Source	Value	Source	Value	Source
0	Disabled	5	kWh Imp. H01	10	kvarh Total RMS	15	kvarh Exp. H01
1	kWh Total RMS	6	kWh Exp. H01	11	kvarh Imp.	16	kvarh TH
2	kWh Imp.	7	kWh TH	12	kvarh Exp.	17	kvarh Imp. TH
3	kWh Exp.	8	kWh Imp. TH	13	kvarh Total Fund.	18	kvarh Exp. TH
4	kWh Total Fund.	9	kWh Exp. TH	14	kvarh Imp. H01		

Table 5-105 Energy Pulse Output Setup Register

5.17.16 Setpoint Setting

Register	Property	Description	Format	Range/Option, Default*	
41401	RW	Setpoint #1	Parameter ¹	UINT32	0*
41403	RW		Type	UINT16	0=Disabled*, 1=Over Setpoint, 2=Under Setpoint
41404	RW		Active Limit	INT32	-2147483647 to 2147483647, Null*
41406	RW		Return Limit	INT32	-2147483647 to 2147483647, Null*
41408	RW		Active Delay	UINT32	0 to 999,999 (x0.01s), 1000*
41410	RW		Trigger Action ²	BITMAP	0=Disabled*
41412	RW		Inactive Delay	UINT32	0 to 999,999 (x0.01s), 1000*
41414	RW	Setpoint #2	Parameter ¹	UINT32	0*
41416	RW		Type	UINT16	0=Disabled*, 1=Over Setpoint, 2=Under Setpoint
41417	RW		Active Limit	INT32	-2147483647 to 2147483647, Null*
41419	RW		Return Limit	INT32	-2147483647 to 2147483647, Null*
41421	RW		Active Delay	UINT32	0 to 999,999 (x0.01s), 1000*
41423	RW		Trigger Action ²	BITMAP	0=Disabled*
41425	RW	Inactive Delay	UINT32	0 to 999,999 (x0.01s), 1000*	
41427	RW	Setpoint #3	
41440	RW	Setpoint #4	
41453	RW	Setpoint #5	
41466	RW	Setpoint #6	
41479	RW	Setpoint #7	
41492	RW	Setpoint #8	
41505	RW	Setpoint #9	
...	
42220	RW	Setpoint #64	

Table 5-106 Setpoint Setting

Notes:

- The iMeter 7A provides the following Setpoint parameters. Parameter 1 to 19 can be set with a shorter Active/Inactive Delay range from 0.01s to 0.99s (i.e., 1/2 cycle to 49.5 cycles) for a high-speed setpoint action.

ID	Parameter	Resolution	ID	Parameter	Resolution
0	Null	--			
Basic (~ Available in Firmware V2.50.08 or later)					
1	UIn	0.1V	101	U2 Unbalance	0.1%
2	UII	0.1V	102	I0 Unbalance	0.1%
3	U4	0.1V	103	I2 Unbalance	0.1%
4	I	0.1A	104	U Fund.	0.1V
5	I4	0.1A	105	I Fund.	0.1A
6	Reserved	--	106	U Deviation	0.1%
7	P Total	0.1W	107	U Over Deviation	0.1%
8	Q Total	0.1var	108	U Under Deviation	0.1%
9	S Total	0.1VA	109	Frequency	0.01Hz
10	PF Total	0.001	110	Frequency Deviation	0.01Hz
11	U1	0.1V	212	Phase Loss	--
12	U2	0.1V	213	Phase Reversal	--
13	U0	0.1V	214	AI1	0.1
14	I1	0.1A	215	AI2	0.1
15	I2	0.1A	216	TC1	°C
16	I0	0.1A	217	TC2	°C
17	Rapid Freq. (HS Freq.)~	0.01Hz	218	2kHz-150kHz C.E.	0.1V
18	Freq. Deviation~	0.01Hz	219	Pst	0.1
19	Rate of Freq. Change~	0.01Hz/s	220	Plt	0.1
100	U0 Unbalance	0.1%	222	Reserved	--
Harmonics					
Harmonics Distortion					

111	U THD	0.1%	116	I TEHD	0.1%
112	U TOHD	0.1%	135	U TOHD	0.1%
113	U TEHD	0.1%	136	U TEHD	0.1%
114	I THD	0.1%	137	I TOHD	0.1%
115	I TOHD	0.1%	138	I TEHD	0.1%
Individual Harmonics Distortion					
0x20000	U HD02	0.1%	0x40000000	I HD02	0.1%
0x30000	U HD03	0.1%	0x41000000	I HD03	0.1%
...
0x3F0000	U HD63	0.1%	0x7D000000	I HD63	0.1%
Harmonics RMS					
123	U TH RMS	0.1V	126	I TH RMS	0.1A
124	U TOH RMS	0.1V	127	I TOH RMS	0.1A
125	U TEH RMS	0.1V	128	I TEH RMS	0.1A
Individual Harmonics RMS					
0x400000	U H02 RMS	0.1V	0x20000000	I H02 RMS	0.1A
0x410000	U H03 RMS	0.1V	0x30000000	I H03 RMS	0.1A
...
0x7D0000	U H63 RMS	0.1V	0x3F000000	I H63 RMS	0.1A
Interharmonics					
Interharmonics Distortion			Interharmonics RMS		
117	U TIHD	0.1%	129	U TIH RMS	0.1V
118	U TOIHD	0.1%	130	U TOIH RMS	0.1V
119	U TEIHD	0.1%	131	U TEIH RMS	0.1V
120	I TIHD	0.1%	132	I TIH RMS	0.1A
121	I TOIHD	0.1%	133	I TOIH RMS	0.1A
122	I TEIHD	0.1%	134	I TEIH RMS	0.1A
Individual Interharmonics Distortion			Individual Interharmonics RMS		
0x810000	U IHD01	0.1%	0x81000000	I IH01 RMS	0.1A
0x820000	U IHD02	0.1%	0x82000000	I IH02 RMS	0.1A
...
0xBF0000	U IHD63	0.1%	0xBF000000	I IH63 RMS	0.1A
Demand					
Present			Predicted		
200	P Total Imp. DMD	0.1W	206	P Total Imp. DMD	0.1W
201	Q Total Imp. DMD	0.1var	207	Q Total Imp. DMD	0.1var
202	P Total Exp. DMD	0.1W	208	P Total Exp. DMD	0.1W
203	Q Total Exp. DMD	0.1var	209	Q Total Exp. DMD	0.1var
204	S Total Exp. DMD	0.1VA	210	S Total Exp. DMD	0.1VA
205	PF Total DMD	0.001	211	PF Total DMD	0.001

Table 5-107 Setpoint Parameters

2. The iMeter 7A provides the following Setpoint Triggers.

BIT	Trigger	BIT	Trigger	BIT	Trigger
0	Alarm	17	DR #3	25	iTrigger 2
1	DO1 Closed	18	DR #4	26	iTrigger 3
2	DO2 Closed	19	DR #5	27	DWR
3	DO3 Closed	20	DR #6	28	WFR
4	DO4 Closed	21	DR #7	29	RMSR
5-14	Reserved	22	DR #8	30~31	Reserved
15	DR #1	23	Reserved		
16	DR #2	24	iTrigger 1		

Table 5-108 Setpoint Trigger

5.17.17 SDR Setting

Register	Property	Description	Format
45700~45766	RW	SDR #1	See Section 5.17.17.1 SDR Setup Data Structure
45800~45866	RW	SDR #2	
45900~45966	RW	SDR #3	
46000~46066	RW	SDR #4	
46100~46166	RW	SDR #5	
46200~46266	RW	SDR #6	
46300~46366	RW	SDR #7	
46400~46466	RW	SDR #8	
46500~46566	RW	SDR #9	
46600~46666	RW	SDR #10	

46700~46766	RW	SDR #11
46800~46866	RW	SDR #12
46900~46966	RW	SDR #13
47000~47066	RW	SDR #14
47100~47166	RW	SDR #15
47200~47266	RW	SDR #16

Table 5-109 SDR Setup Registers

5.17.17.1 SDR Setup Data Structure

Offset	Property	Description	Format	Range/Option
+0	RW	Recording Interval	UINT32	1 to 60 (min)
+1	RW	Recording Mode	UINT16	0=Stop-When-Full, 1=First-In-First-Out
+2	RW	Number of Parameters	UINT16	0 to 64
+3	RW	Parameter 1	UINT16	Please refer to Appendix A for a complete list of the SDR Parameters
+4	RW	Parameter 2	UINT16	
...	RW	...	UINT16	
+66	RW	Parameter 64	UINT16	

Table 5-110 SDR Setup Data Structure

5.17.17.2 SDR Default Setting

Parameter	SDR 1	SDR 2	SDR 3	SDR 4
Recording Interval	10	10	10	10
Recording Mode	1=FIFO	1=FIFO	1=FIFO	1=FIFO
Number of Parameters	59	60	56	63
Parameter 1	Freq.	Ua Angle	Ua THD	Ua TH RMS
Parameter 2	Ua RMS	Ub Angle	Ub THD	Ub TH RMS
Parameter 3	Ub RMS	Uc Angle	Uc THD	Uc TH RMS
Parameter 4	Uc RMS	U4 Angle	U4 THD	U4 TH RMS
Parameter 5	U4 RMS	Uab Angle	Ia THD	Ia TH RMS
Parameter 6	Uln RMS Avg.	Ubc Angle	Ib THD	Ib TH RMS
Parameter 7	Uab RMS	Uca Angle	Ic THD	Ic TH RMS
Parameter 8	Ubc RMS	Ia Angle	I4 THD	I4 TH RMS
Parameter 9	Uca RMS	Ib Angle	Ua TOHD	Pa TH
Parameter 10	Ull RMS Avg.	Ic Angle	Ub TOHD	Pb TH
Parameter 11	Ia RMS	I4 Angle	Uc TOHD	Pc TH
Parameter 12	Ib RMS	Ua Fund. Angle	U4 TOHD	P Total TH
Parameter 13	Ic RMS	Ub Fund. Angle	Ia TOHD	Qa TH
Parameter 14	I4 RMS	Uc Fund. Angle	Ib TOHD	Qb TH
Parameter 15	Current RMS Avg.	U4 Fund. Angle	Ic TOHD	Qc TH
Parameter 16	Pa	Uab Fund. Angle	I4 TOHD	Q Total TH
Parameter 17	Pb	Ubc Fund. Angle	Ua TEHD	Sa TH
Parameter 18	Pc	Uca Fund. Angle	Ub TEHD	Sb TH
Parameter 19	P Total	Ia Fund. Angle	Uc TEHD	Sc TH
Parameter 20	Qa	Ib Fund. Angle	U4 TEHD	S Total TH
Parameter 21	Qb	Ic Fund. Angle	Ia TEHD	PFa TH
Parameter 22	Qc	I4 Fund. Angle	Ib TEHD	PFb TH
Parameter 23	Q Total	U0	Ic TEHD	PFc TH
Parameter 24	Sa	U2	I4 TEHD	PF TH
Parameter 25	Sb	U1	Ia K-Factor	Ua DC Component
Parameter 26	Sc	I0	Ib K-Factor	Ub DC Component
Parameter 27	S Total	I2	Ic K-Factor	Uc DC Component
Parameter 28	PFa	I1	I4 K-Factor	U4 DC Component
Parameter 29	PFb	U2 Unbalance	Ia TDD	Uab DC Component
Parameter 30	PFc	I2 Unbalance	Ib TDD	Ubc DC Component
Parameter 31	PF Total	U0 Unbalance	Ic TDD	Uca DC Component
Parameter 32	Ua Fund. RMS	I0 Unbalance	I4 TDD	Ia DC RMS
Parameter 33	Ub Fund. RMS	Ua Deviation	Ua TIHD	Ib DC RMS
Parameter 34	Uc Fund. RMS	Ub Deviation	Ub TIHD	Ic DC RMS
Parameter 35	U4 Fund. RMS	Uc Deviation	Uc TIHD	I4 DC RMS
Parameter 36	Uab Fund. RMS	Uab Deviation	U4 TIHD	Ua HD01
Parameter 37	Ubc Fund. RMS	Ubc Deviation	Ia TIHD	Ub HD01
Parameter 38	Uca Fund. RMS	Uca Deviation	Ib TIHD	Uc HD01
Parameter 39	Ia Fund. RMS	Ua Over Deviation	Ic TIHD	U4 HD01
Parameter 40	Ib Fund. RMS	Ub Over Deviation	I4 TIHD	Ua HD03
Parameter 41	Ic Fund. RMS	Uc Over Deviation	Ua TOIHD	Ub HD03

CET Electric Technology

Parameter 42	I4 Fund. RMS	Uab Over Deviation	Ub TOIHD	Uc HD03
Parameter 43	Pa Fund.	Ubc Over Deviation	Uc TOIHD	U4 HD03
Parameter 44	Pb Fund.	Uca Over Deviation	U4 TOIHD	Ua HD05
Parameter 45	Pc Fund.	Ua Under Deviation	Ia TOIHD	Ub HD05
Parameter 46	P Total Fund.	Ub Under Deviation	Ib TOIHD	Uc HD05
Parameter 47	Qa Fund.	Uc Under Deviation	Ic TOIHD	U4 HD05
Parameter 48	Qb Fund.	Uab Under Deviation	I4 TOIHD	Ua HD07
Parameter 49	Qc Fund.	Ubc Under Deviation	Ua TEIHD	Ub HD07
Parameter 50	Q Total Fund.	Uca Under Deviation	Ub TEIHD	Uc HD07
Parameter 51	Sa Fund.	Freq. Deviation	Uc TEIHD	U4 HD07
Parameter 52	Sb Fund.	Uab THD	U4 TEIHD	Ua HD09
Parameter 53	Sc Fund.	Ubc THD	Ia TEIHD	Ub HD09
Parameter 54	S Total Fund.	Uca THD	Ib TEIHD	Uc HD09
Parameter 55	dPFa	Uab TOHD	Ic TEIHD	U4 HD09
Parameter 56	dPFb	Ubc TOHD	I4 TEIHD	Ua HD11
Parameter 57	dPFc	Uca TOHD		Ub HD11
Parameter 58	dPF Total	Uab TEHD		Uc HD11
Parameter 59	I Residual (Cal.)	Ubc TEHD		U4 HD11
Parameter 60		Uca TEHD		Ua HD13
Parameter 61				Ub HD13
Parameter 62				Uc HD13
Parameter 63				U4 HD13
Parameter 64				
Parameter	SDR 5	SDR 6	SDR 7	SDR 8
Recording Interval	10	10	10	10
Recording Mode	1=FIFO	1=FIFO	1=FIFO	1=FIFO
Number of Parameters	64	62	62	58
Parameter 1	Ua HD15	Ua HD47	Ia HD39	Ia H25 RMS
Parameter 2	Ub HD15	Ub HD47	Ib HD39	Ib H25 RMS
Parameter 3	Uc HD15	Uc HD47	Ic HD39	Ic H25 RMS
Parameter 4	U4 HD15	U4 HD47	Ia HD41	I4 H25 RMS
Parameter 5	Ua HD17	Ua HD49	Ib HD41	Ia H27 RMS
Parameter 6	Ub HD17	Ub HD49	Ic HD41	Ib H27 RMS
Parameter 7	Uc HD17	Uc HD49	Ia HD43	Ic H27 RMS
Parameter 8	U4 HD17	U4 HD49	Ib HD43	I4 H27 RMS
Parameter 9	Ua HD19	Ia HD03	Ic HD43	Ia H29 RMS
Parameter 10	Ub HD19	Ib HD03	Ia HD45	Ib H29 RMS
Parameter 11	Uc HD19	Ic HD03	Ib HD45	Ic H29 RMS
Parameter 12	U4 HD19	Ia HD05	Ic HD45	I4 H29 RMS
Parameter 13	Ua HD21	Ib HD05	Ia HD47	Ia H31 RMS
Parameter 14	Ub HD21	Ic HD05	Ib HD47	Ib H31 RMS
Parameter 15	Uc HD21	Ia HD07	Ic HD47	Ic H31 RMS
Parameter 16	U4 HD21	Ib HD07	Ia HD49	I4 H31 RMS
Parameter 17	Ua HD23	Ic HD07	Ib HD49	Ia H33 RMS
Parameter 18	Ub HD23	Ia HD09	Ic HD49	Ib H33 RMS
Parameter 19	Uc HD23	Ib HD09	Ia H03 RMS	Ic H33 RMS
Parameter 20	U4 HD23	Ic HD09	Ib H03 RMS	I4 H33 RMS
Parameter 21	Ua HD25	Ia HD11	Ic H03 RMS	Ia H35 RMS
Parameter 22	Ub HD25	Ib HD11	I4 H03 RMS	Ib H35 RMS
Parameter 23	Uc HD25	Ic HD11	Ia H05 RMS	Ic H35 RMS
Parameter 24	U4 HD25	Ia HD13	Ib H05 RMS	I4 H35 RMS
Parameter 25	Ua HD27	Ib HD13	Ic H05 RMS	Ia H37 RMS
Parameter 26	Ub HD27	Ic HD13	I4 H05 RMS	Ib H37 RMS
Parameter 27	Uc HD27	Ia HD15	Ia H07 RMS	Ic H37 RMS
Parameter 28	U4 HD27	Ib HD15	Ib H07 RMS	I4 H37 RMS
Parameter 29	Ua HD29	Ic HD15	Ic H07 RMS	Ia H39 RMS
Parameter 30	Ub HD29	Ia HD17	I4 H07 RMS	Ib H39 RMS
Parameter 31	Uc HD29	Ib HD17	Ia H09 RMS	Ic H39 RMS
Parameter 32	U4 HD29	Ic HD17	Ib H09 RMS	I4 H39 RMS
Parameter 33	Ua HD31	Ia HD19	Ic H09 RMS	Ia H41 RMS
Parameter 34	Ub HD31	Ib HD19	I4 H09 RMS	Ib H41 RMS
Parameter 35	Uc HD31	Ic HD19	Ia H11 RMS	Ic H41 RMS
Parameter 36	U4 HD31	Ia HD21	Ib H11 RMS	I4 H41 RMS
Parameter 37	Ua HD33	Ib HD21	Ic H11 RMS	Ia H43 RMS
Parameter 38	Ub HD33	Ic HD21	I4 H11 RMS	Ib H43 RMS
Parameter 39	Uc HD33	Ia HD23	Ia H13 RMS	Ic H43 RMS

Parameter 40	U4 HD33	Ib HD23	Ib H13 RMS	I4 H43 RMS
Parameter 41	Ua HD35	Ic HD23	Ic H13 RMS	Ia H45 RMS
Parameter 42	Ub HD35	Ia HD25	I4 H13 RMS	Ib H45 RMS
Parameter 43	Uc HD35	Ib HD25	Ia H15 RMS	Ic H45 RMS
Parameter 44	U4 HD35	Ic HD25	Ib H15 RMS	I4 H45 RMS
Parameter 45	Ua HD37	Ia HD27	Ic H15 RMS	Ia H47 RMS
Parameter 46	Ub HD37	Ib HD27	I4 H15 RMS	Ib H47 RMS
Parameter 47	Uc HD37	Ic HD27	Ia H17 RMS	Ic H47 RMS
Parameter 48	U4 HD37	Ia HD29	Ib H17 RMS	I4 H47 RMS
Parameter 49	Ua HD39	Ib HD29	Ic H17 RMS	Ia H49 RMS
Parameter 50	Ub HD39	Ic HD29	I4 H17 RMS	Ib H49 RMS
Parameter 51	Uc HD39	Ia HD31	Ia H19 RMS	Ic H49 RMS
Parameter 52	U4 HD39	Ib HD31	Ib H19 RMS	I4 H49 RMS
Parameter 53	Ua HD41	Ic HD31	Ic H19 RMS	Ua Pst
Parameter 54	Ub HD41	Ia HD33	I4 H19 RMS	Ub Pst
Parameter 55	Uc HD41	Ib HD33	Ia H21 RMS	Uc Pst
Parameter 56	U4 HD41	Ic HD33	Ib H21 RMS	Ua Plt
Parameter 57	Ua HD43	Ia HD35	Ic H21 RMS	Ub Plt
Parameter 58	Ub HD43	Ib HD35	I4 H21 RMS	Uc Plt
Parameter 59	Uc HD43	Ic HD35	Ia H23 RMS	
Parameter 60	U4 HD43	Ia HD37	Ib H23 RMS	
Parameter 61	Ua HD45	Ib HD37	Ic H23 RMS	
Parameter 62	Ub HD45	Ic HD37	I4 H23 RMS	
Parameter 63	Uc HD45			
Parameter 64	U4 HD45			

Table 5-111 SDR Default Setting

5.17.18 DR Setting

Register	Property	Description	Format
47300~47370	RW	Data Recorder #1	See Section 5.17.18.1 Data Recorder Setup Data Structure
47400~47470	RW	Data Recorder #2	
47500~47570	RW	Data Recorder #3	
47600~47670	RW	Data Recorder #4	
47700~47770	RW	Data Recorder #5	
47800~47870	RW	Data Recorder #6	
47900~47970	RW	Data Recorder #7	
48000~48070	RW	Data Recorder #8	

Table 5-112 Data Recorder Setup Registers

5.17.18.1 Data Recorder Setup Data Structure

Offset	Property	Description	Format	Range/Options
+0	RW	Trigger Mode ¹	UINT16	0=Disabled, 1=Triggered by Timer 2=Triggered by Setpoint
+1	RW	Recording Mode	UINT16	0=Stop-When-Full, 1=First-In-Frist-Out
+2	RW	Reserved	UINT16	
+3	RW	Recording Interval	UINT32	1 to 3,456,000 (s)
+5	RW	Recording Offset ²	UINT16	0 to 43200 (s)
+6	RW	Number of Parameters ³	UINT16	0 to 64
+7	RW	Parameter 1	UINT16	Please refer to Appendix A for a complete list of the Data Recorder Parameters.
+8	RW	Parameter 2	UINT16	
+9	RW	Parameter 3	UINT16	
+10	RW	Parameter 4	UINT16	
+11	RW	Parameter 5	UINT16	
+12	RW	Parameter 6	UINT16	
+13	RW	Parameter 7	UINT16	
+14	RW	Parameter 8	UINT16	
+15	RW	Parameter 9	UINT16	
+16	RW	Parameter 10	UINT16	
+17	RW	Parameter 11	UINT16	
+18	RW	Parameter 12	UINT16	
+19	RW	Parameter 13	UINT16	
+20	RW	Parameter 14	UINT16	
+21	RW	Parameter 15	UINT16	
+22	RW	Parameter 16	UINT16	
+23	RW	Parameter 17	UINT16	

+24	RW	Parameter 18	UINT16
+25	RW	Parameter 19	UINT16
+26	RW	Parameter 20	UINT16
+27	RW	Parameter 21	UINT16
+28	RW	Parameter 22	UINT16
+29	RW	Parameter 23	UINT16
+30	RW	Parameter 24	UINT16
+31	RW	Parameter 25	UINT16
+32	RW	Parameter 26	UINT16
+33	RW	Parameter 27	UINT16
+34	RW	Parameter 28	UINT16
+35	RW	Parameter 29	UINT16
+36	RW	Parameter 30	UINT16
+37	RW	Parameter 31	UINT16
+38	RW	Parameter 32	UINT16
...			
+70	RW	Parameter 64	UINT16

Table 5-113 DR Setup Data Structure

Notes:

- 1) The Data Recorder can be triggered by Setpoint (**Triggered by Setpoint**) or on a time basis using the meter clock (**Triggered by Timer**). For **Triggered by Setpoint**, when the Setpoint goes active, the Data Recorder starts to record, and when the Setpoint becomes inactive, the Data Recorder stops.
- 2) **Recording Offset** can be used to delay the recording by a fixed time from the **Recording Interval**. For example, if **Recording Interval** is set to 3600 (hourly) and **Recording Offset** is set to 300 (5 minutes), the recording will take place at 5 minutes after the hour every hour, i.e. 00:05, 01:05, 02:05...etc. The programmed value of **Recording Offset** should be less than that of **Recording Interval**.
- 3) **Appendix A** provides a list of available parameters for data recording. If **Number of parameters** is set to 0, the Data Recorder is disabled.

5.17.18.2 DR Default Setting

Parameter	DR 1	DR 2	DR 3	DR 4
Trigger Mode	1=Triggered by Timer	1=Triggered by Timer	1=Triggered by Timer	1=Triggered by Timer
Recording Mode	1=FIFO	1=FIFO	1=FIFO	1=FIFO
Recording Interval	900	900	900	900
Offset Time	0	0	0	0
Number of Parameters	31	31	29	27
Parameter 1	Uab	Uab Demand	Uab Deviation	Ua THD
Parameter 2	Ubc	Ubc Demand	Ubc Deviation	Ub THD
Parameter 3	Uca	Uca Demand	Uca Deviation	Uc THD
Parameter 4	Ull avg	Ull avg Demand	Ua Deviation	Uab THD
Parameter 5	Ia	Ia Demand	Ub Deviation	Ubc THD
Parameter 6	Ib	Ib Demand	Uc Deviation	Uca THD
Parameter 7	Ic	Ic Demand	Uab Over Deviation	Ia THD
Parameter 8	I avg	I avg Demand	Ubc Over Deviation	Ib THD
Parameter 9	P Total	P Total Imp Demand	Uca Over Deviation	Ic THD
Parameter 10	Q Total	Q Total Imp Demand	Ua Over Deviation	Ia TDD
Parameter 11	S Total	S Total Demand	Ub Over Deviation	Ib TDD
Parameter 12	PF Total	PF Total Demand	Uc Over Deviation	Ic TDD
Parameter 13	Freq	Freq Demand	Uab Under Deviation	Ia K-Factor
Parameter 14	Ua	Ua Demand	Ubc Under Deviation	Ib K-Factor
Parameter 15	Ub	Ub Demand	Uca Under Deviation	Ic K-Factor
Parameter 16	Uc	Uc Demand	Ua Under Deviation	Ua Crest Factor
Parameter 17	Uln avg	Uln avg Demand	Ub Under Deviation	Ub Crest Factor
Parameter 18	Pa	Pa Imp. Demand	Uc Under Deviation	Uc Crest Factor
Parameter 19	Pb	Pb Imp. Demand	Freq. Deviation	Ia Crest Factor
Parameter 20	Pc	Pc Imp. Demand	U0 Unbalance	Ib Crest Factor
Parameter 21	Qa	Qa Imp. Demand	I0 Unbalance	Ic Crest Factor
Parameter 22	Qb	Qb Imp. Demand	U2 Unbalance	Ua Pst
Parameter 23	Qc	Qc Imp. Demand	I2 Unbalance	Ub Pst
Parameter 24	Sa	Sa Demand	U0 (Zero Sequence)	Uc Pst
Parameter 25	Sb	Sb Demand	U1 (+ve Sequence)	Ua Plt
Parameter 26	Sc	Sc Demand	U2 (-ve Sequence)	Ub Plt
Parameter 27	PFa	PFa Demand	I0 (Zero Sequence)	Uc Plt
Parameter 28	PFb	PFb Demand	I1 (+ve Sequence)	
Parameter 29	PFc	PFc Demand	I2 (-ve Sequence)	
Parameter 30	U4	U4 Demand		

Parameter 31	I4	I4 Demand		
Parameter 32				
Parameter	DR 5	DR 6	DR 7	DR 8
Trigger Mode	0=Disable	0=Disable	0=Disable	0=Disable
Recording Mode	1=FIFO	1=FIFO	1=FIFO	1=FIFO
Recording Interval	900	900	900	900
Recording Offset	0	0	0	0
No. of Parameters	0	0	0	0
Parameter 1				
...				
Parameter 32				

Table 5-114 DR Default Setting

5.17.19 Max./Min. Recorder Setting

The **Self-Read Time** allows the user to specify the time and day of the month for the Max./Min. Log Self-Read operation. The **Self-Read Time** supports three options:

- A zero value means that the Self-Read will take place at 00:00 of the first day of each month.
- A non-zero value means that the Self-Read will take place at a specific time and day based on the formula: Self-Read Time = Day * 100 + Hour where 0 ≤ Hour ≤ 23 and 1 ≤ Day ≤ 28. For example, the value 1512 means that the Self-Read will take place at 12:00 pm on the 15th day of each month.
- A 0xFFFF value will disable the Self-Read operation and replace it with manual operation. A manual reset will cause the Max. Demand of **This Month** to be transferred to the Max. Demand of **Last Month** and then reset. The terms **This Month** and **Last Month** will become **Since Last Reset** and **Before Last Reset**.

5.17.19.1 Max./Min. Recorder #1 Setup

Max.	Min.	Property	Description	Format	Range/Option, Default*
48900	49300	RW	Self-read Time	UINT16	Manual/Auto, 0xFFFF*
48901	49301	RW	Number of Parameters	UINT16	0 to 19*
48902	49302	RW	Parameter #1	UINT16	Uab*
48903	49303	RW	Parameter #2	UINT16	Ubc*
48904	49304	RW	Parameter #3	UINT16	Uca*
48905	49305	RW	Parameter #4	UINT16	Ull avg*
48906	49306	RW	Parameter #5	UINT16	Ia*
48907	49307	RW	Parameter #6	UINT16	Ib*
48908	49308	RW	Parameter #7	UINT16	Ic*
48909	49309	RW	Parameter #8	UINT16	I avg*
48910	49310	RW	Parameter #9	UINT16	P Total*
48911	49311	RW	Parameter #10	UINT16	Q Total*
48912	49312	RW	Parameter #11	UINT16	S Total*
48913	49313	RW	Parameter #12	UINT16	PF Total*
48914	49314	RW	Parameter #13	UINT16	Freq*
48915	49315	RW	Parameter #14	UINT16	Ua*
48916	49316	RW	Parameter #15	UINT16	Ub*
48917	49317	RW	Parameter #16	UINT16	Uc*
48918	49318	RW	Parameter #17	UINT16	Uln avg*
48919	49319	RW	Parameter #18	UINT16	U4*
48920	49320	RW	Parameter #19	UINT16	I4*
48921	49321	RW	Parameter #20	UINT16	

Table 5-115 Max./Min. Recorder #1 Setup

5.17.19.2 Max./Min. Recorder #2 Setup

Max.	Min.	Property	Description	Format	Range/Option, Default*
49000	49400	RW	Self-read Time	UINT16	Manual/Auto, 0xFFFF*
49001	49401	RW	Number of Parameters	UINT16	0 to 20, 16*
49002	49402	RW	Parameter #1	UINT16	Pa*
49003	49403	RW	Parameter #2	UINT16	Pb*
49004	49404	RW	Parameter #3	UINT16	Pc*
49005	49405	RW	Parameter #4	UINT16	Qa*
49006	49406	RW	Parameter #5	UINT16	Qb*
49007	49407	RW	Parameter #6	UINT16	Qc*
49008	49408	RW	Parameter #7	UINT16	Sa*
49009	49409	RW	Parameter #8	UINT16	Sb*
49010	49410	RW	Parameter #9	UINT16	Sc*
49011	49411	RW	Parameter #10	UINT16	PFa*

49012	49412	RW	Parameter #11	UINT16	Pfb*
49013	49413	RW	Parameter #12	UINT16	PFc*
49014	49414	RW	Parameter #13	UINT16	U0 Unb.*
49015	49415	RW	Parameter #14	UINT16	I0 Unb.*
49016	49416	RW	Parameter #15	UINT16	U2 Unb.*
49017	49417	RW	Parameter #16	UINT16	I2 Unb.*
49018	49418	RW	Parameter #17	UINT16	
49019	49419	RW	Parameter #18	UINT16	
49020	49420	RW	Parameter #19	UINT16	
49021	49421	RW	Parameter #20	UINT16	

Table 5-116 Max. Recorder #2 Setup

5.17.19.3 Max./Min. Recorder #3 Setup

Max.	Min.	Property	Description	Format	Range/Option, Default*
49100	49500	RW	Self-read Time	UINT16	Manual/Auto, 0xFFFF*
49101	49501	RW	Number of Parameters	UINT16	0 to 20, 18*
49102	49502	RW	Parameter #1	UINT16	Ua THD*
49103	49503	RW	Parameter #2	UINT16	Ub THD*
49104	49504	RW	Parameter #3	UINT16	Uc THD*
49105	49505	RW	Parameter #4	UINT16	Ia THD*
49106	49506	RW	Parameter #5	UINT16	Ib THD*
49107	49507	RW	Parameter #6	UINT16	Ic THD*
49108	49508	RW	Parameter #7	UINT16	Ia TDD*
49109	49509	RW	Parameter #8	UINT16	Ib TDD*
49110	49510	RW	Parameter #9	UINT16	Ic TDD*
49111	49511	RW	Parameter #10	UINT16	Ia K-Factor*
49112	49512	RW	Parameter #11	UINT16	Ib K-Factor*
49113	49513	RW	Parameter #12	UINT16	Ic K-Factor*
49114	49514	RW	Parameter #13	UINT16	Ua Crest Factor*
49115	49515	RW	Parameter #14	UINT16	Ub Crest Factor*
49116	49516	RW	Parameter #15	UINT16	Uc Crest Factor*
49117	49517	RW	Parameter #16	UINT16	Ia Crest Factor*
49118	49518	RW	Parameter #17	UINT16	Ib Crest Factor*
49119	49519	RW	Parameter #18	UINT16	Ic Crest Factor*
49120	49520	RW	Parameter #19	UINT16	
49121	49521	RW	Parameter #20	UINT16	

Table 5-117 Max./Min. Recorder #3 Setup

5.17.19.4 Max./Min. Recorder #4 Setup

Max.	Min.	Property	Description	Format	Range/Option, Default*
49200	49600	RW	Self-read Time	UINT16	Manual/Auto, 0xFFFF*
49201	49601	RW	Number of Parameters	UINT16	0 to 20, 19*
49202	49602	RW	Parameter #1	UINT16	U0 (Zero Sequence)
49203	49603	RW	Parameter #2	UINT16	U1 (+ve Sequence)
49204	49604	RW	Parameter #3	UINT16	U2 (-ve Sequence)
49205	49605	RW	Parameter #4	UINT16	I0 (Zero Sequence)
49206	49606	RW	Parameter #5	UINT16	I1 (+ve Sequence)
49207	49607	RW	Parameter #6	UINT16	I2 (-ve Sequence)
49208	49608	RW	Parameter #7	UINT16	Ua Pst
49209	49609	RW	Parameter #8	UINT16	Ub Pst
49210	49610	RW	Parameter #9	UINT16	Uc Pst
49211	49611	RW	Parameter #10	UINT16	Ua Plt
49212	49612	RW	Parameter #11	UINT16	Ub Plt
49213	49613	RW	Parameter #12	UINT16	Uc Plt
49214	49614	RW	Parameter #13	UINT16	Uab Deviation
49215	49615	RW	Parameter #14	UINT16	Ubc Deviation
49216	49616	RW	Parameter #15	UINT16	Uca Deviation
49217	49617	RW	Parameter #16	UINT16	Ua Deviation
49218	49618	RW	Parameter #17	UINT16	Ub Deviation
49219	49619	RW	Parameter #18	UINT16	Uc Deviation
49220	49620	RW	Parameter #19	UINT16	Freq. Dev.
49221	49621	RW	Parameter #20	UINT16	

Table 5-118 Max./Min. Recorder #4 Setup

5.17.20 IER/AER Setting

5.17.20.1 3-phase Total IER/AER Setting

AER	IER	Property	Description	Format	Range/Option, Default*	
49700	49706	RW	Recording Mode	UINT16	0=Disabled 1=Stop-When-Full 2=First-In-First-Out*	
49701	49707	RW	Recording Interval	UINT16	1 to 65535 (min), 15*	
49702-49704	49708-49710	RW	Start Time	High-order Byte: Year	UINT16	0-37 (Year-2000)
				Low-order Byte: Month		1 to 12
				High-order Byte: Day	UINT16	1 to 31
				Low-order Byte: Hour		0 to 23
				High-order Byte: Minute	UINT16	0 to 59
			Low-order Byte: Second		0 to 59	

Table 5-119 3-phase Total IER/AER Setting

5.17.20.2 Per-phase IER/AER Setting

AER	IER	Property	Description	Format	Range/Option, Default*	
49712	49718	RW	Recording Mode	UINT16	0=Disabled* 1=Stop-When-Full 2=First-In-First-Out	
49713	49719	RW	Recording Interval	UINT16	1 to 65535 (min), 15*	
49714-49716	49720-49722	RW	Start Time	High-order Byte: Year	UINT16	0-37 (Year-2000)
				Low-order Byte: Month		1 to 12
				High-order Byte: Day	UINT16	1 to 31
				Low-order Byte: Hour		0 to 23
				High-order Byte: Minute	UINT16	0 to 59
			Low-order Byte: Second		0 to 59	

Table 5-120 Per-phase IER/AER Setting

5.17.21 EN 50160 Setting

The default values in Section 5.17.21.2 may be different for LV, MV and HV levels such that it’s required to set Register 49790 Voltage Level first.

5.17.21.1 Basic

Register	Property	Description	Format	Range/Option, Default*
49790	RW	Voltage Level	UINT16	0=LV*, 1=MV, 2=HV, 3=EHV~
49791	RW	Start Week	UINT16	0=Sunday* 1~6=Monday to Saturday
49792	RW	Enable EN 50160 Report	UINT16	0=No, 1=Yes*

~Available in Firmware V2.50.08 or later

Table 5-121 EN 50160 Basic Setup

5.17.21.2 EN 50160 Parameters

Register	Property	Description	Format	Scale/Unit, Default*
49800	RW	Freq Wide Tolerance	INT32	10000* (x0.0001, %)
49802	RW	Freq positive deviation wide limit	INT32	10400* (x0.0001, %)
49804	RW	Freq negative deviation wide limit	INT32	9400* (x0.0001, %)
49806	RW	Freq narrow tolerance	INT32	9950* (x0.0001, %)
49808	RW	Freq positive deviation narrow limit	INT32	10100* (x0.0001, %)
49810	RW	Freq negative deviation narrow limit	INT32	9900 (x0.0001, %)
49812	RW	Voltage wide tolerance	INT32	10000* (x0.0001, %)
49814	RW	Voltage positive deviation wide limit	INT32	LV: 11000, MV/LV/EHV: 11500 (x0.0001, %)
49816	RW	Voltage negative deviation wide limit	INT32	8500 (x0.0001, %)
49818	RW	Voltage narrow tolerance	INT32	LV: 9500, MV/HV/EHV: 9900 (x0.0001, %)
49820	RW	Voltage positive deviation narrow limit	INT32	11000 (x0.0001, %)
49822	RW	Voltage negative deviation narrow limit	INT32	9000 (x0.0001, %)
49824	RW	Flicker tolerance	INT32	9500 (x0.0001, %)
49826	RW	Flicker limit	INT32	100 (x0.01)
49828	RW	Voltage Unbalance tolerance	INT32	9500 (x0.0001, %)
49830	RW	Voltage Unbalance limit	INT32	200 (x0.0001, %)

49832	RW	Harmonic Voltage tolerance	INT32	9500 (x0.0001, %)
49834	RW	THD limit	INT32	800 (x0.0001, %)
49836	--	Reserved	--	
49838	--	Reserved	--	
49840	RW	H02 Voltage limit	INT32	LV/MV: 200 HV/EHV: 190 (x0.0001, %)
49842	RW	H03 Voltage limit	INT32	LV/MV: 500, HV/EHV: 300 (x0.0001, %)
49844	RW	H04 Voltage limit	INT32	100 (x0.0001, %)
49846	RW	H05 Voltage limit	INT32	LV/MV: 600, HV/EHV: 500 (x0.0001, %)
49848	RW	H06 Voltage limit	INT32	50 (x0.0001, %)
49850	RW	H07 Voltage limit	INT32	LV/MV: 500, HV/EHV: 400 (x0.0001, %)
49852	RW	H08 Voltage limit	INT32	50 (x0.0001, %)
49854	RW	H09 Voltage limit	INT32	LV/MV: 150, HV/EHV: 130 (x0.0001, %)
49856	RW	H10 Voltage limit	INT32	50 (x0.0001, %)
49858	RW	H11 Voltage limit	INT32	LV/MV: 350, HV/EHV: 300 (x0.0001, %)
49860	RW	H12 Voltage limit	INT32	50 (x0.0001, %)
49862	RW	H13 Voltage limit	INT32	LV/MV: 300, HV/EHV: 250 (x0.0001, %)
49864	RW	H14 Voltage limit	INT32	50 (x0.0001, %)
49866	RW	H15 Voltage limit	INT32	LV: 100, MV/HV/EHV: 50 (x0.0001, %)
49868	RW	H16 Voltage limit	INT32	50 (x0.0001, %)
49870	RW	H17 Voltage limit	INT32	LV/MV: 200, HV/EHV: 10000 (x0.0001, %)
49872	RW	H18 Voltage limit	INT32	50 (x0.0001, %)
49874	RW	H19 Voltage limit	INT32	LV/MV: 150, HV/EHV: 10000 (x0.0001, %)
49876	RW	H20 Voltage limit	INT32	50 (x0.0001, %)
49878	RW	H21 Voltage limit	INT32	LV: 75, MV/HV/EHV: 50 (x0.0001, %)
49880	RW	H22 Voltage limit	INT32	50 (x0.0001, %)
49882	RW	H23 Voltage limit	INT32	LV/MV: 150, HV/EHV: 10000 (x0.0001, %)
49884	RW	H24 Voltage limit	INT32	50 (x0.0001, %)
49886	RW	H25 Voltage limit	INT32	LV/MV: 150, HV/EHV: 10000 (x0.0001, %)

Table 5-122 EN 50160 Parameters Setting

5.17.22 TOU Setting

5.17.22.1 Basic Setting

Register	Property	Description	Format	Range/Option, Default*
50100	RW	Sunday Setup	UINT16	0=Weekday1* 1=Weekday2 2=Weekday3
50101	RW	Monday Setup	UINT16	
50102	RW	Tuesday Setup	UINT16	
50103	RW	Wednesday Setup	UINT16	
50104	RW	Thursday Setup	UINT16	
50105	RW	Friday Setup	UINT16	
50106	RW	Saturday Setup	UINT16	
50107	RW	TOU Switch Time	UINT32	See Note 2), 0x7FFFFFFF*
50109	RW	TOU Self-read Time	UINT16	DDHH, 0x0100*

Table 5-123 TOU Basic Setting

Notes:

- 1) If DI1 is not programmed as a **Tariff Switch**, the TOU will function based on the TOU Schedule. If at least one DI (DI1) is programmed as a **Tariff Switch**, the TOU Schedule will no longer be used and the Tariff switching will be based on the status of the DIs.
- 2) The following table illustrates the data structure for the TOU Switch Time. For example, 0x1003140C indicates a switch time of 12:00 pm on March 20th, 2016. Writing 0x7FFFFFFF to this register disables the switching between TOU Schedule.

Byte 3	Byte 2	Byte 1	Byte 0
Year-2000 (0-37)	Month (1-12)	Day (1-31)	Hour (00-23)

Table 5-124 TOU Switch Time Format

5.17.22.2 Season Setting

The iMeter 7A has two sets of Season setup parameters. The base addresses for the two sets are 50200 and 50300 respectively. Register Address = Base Address + Register Offset, for example, season #2’s start date of the second schedule is 50300+4 = 50304.

Offset	Property	Description	Format	Range/Option, Default*
0	RW	Season #1: Start Date ¹	UINT16	0x0101*
1	RW	Season #1: Weekday#1 Daily Profile	UINT16	0* to 19
2	RW	Season #1: Weekday#2 Daily Profile	UINT16	
3	RW	Season #1: Weekday#3 Daily Profile	UINT16	
4	RW	Season #2: Start Date	High-order Byte: Month UINT16	

			Low-order Byte: Day		
5	RW	Season #2: Weekday#1 Daily Profile	UINT16	0* to 19	
6	RW	Season #2: Weekday#2 Daily Profile	UINT16		
7	RW	Season #2: Weekday#3 Daily Profile	UINT16		
8	RW	Season #3: Start Date	UINT16	See Season #2: Start Date	
9	RW	Season #3: Weekday#1 Daily Profile	UINT16	0* to 19	
10	RW	Season #3: Weekday#2 Daily Profile	UINT16		
11	RW	Season #3: Weekday#3 Daily Profile	UINT16		
12	RW	Season #4: Start Date	UINT16	See Season #2: Start Date	
13	RW	Season #4: Weekday#1 Daily Profile	UINT16	0* to 19	
14	RW	Season #4: Weekday#2 Daily Profile	UINT16		
15	RW	Season #4: Weekday#3 Daily Profile	UINT16		
16	RW	Season #5: Start Date	UINT16	See Season #2: Start Date	
17	RW	Season #5: Weekday#1 Daily Profile	UINT16	0* to 19	
18	RW	Season #5: Weekday#2 Daily Profile	UINT16		
19	RW	Season #5: Weekday#3 Daily Profile	UINT16		
20	RW	Season #6: Start Date	UINT16	See Season #2: Start Date	
21	RW	Season #6: Weekday#1 Daily Profile	UINT16	0* to 19	
22	RW	Season #6: Weekday#2 Daily Profile	UINT16		
23	RW	Season #6: Weekday#3 Daily Profile	UINT16		
24	RW	Season #7: Start Date	UINT16	See Season #2: Start Date	
25	RW	Season #7: Weekday#1 Daily Profile	UINT16	0* to 19	
26	RW	Season #7: Weekday#2 Daily Profile	UINT16		
27	RW	Season #7: Weekday#3 Daily Profile	UINT16		
28	RW	Season #8: Start Date	UINT16	See Season #2: Start Date	
29	RW	Season #8: Weekday#1 Daily Profile	UINT16	0* to 19	
30	RW	Season #8: Weekday#2 Daily Profile	UINT16		
31	RW	Season #8: Weekday#3 Daily Profile	UINT16		
32	RW	Season #9: Start Date	UINT16	See Season #2: Start Date	
33	RW	Season #9: Weekday#1 Daily Profile	UINT16	0* to 19	
34	RW	Season #9: Weekday#2 Daily Profile	UINT16		
35	RW	Season #9: Weekday#3 Daily Profile	UINT16		
36	RW	Season #10: Start Date	UINT16	See Season #2: Start Date	
37	RW	Season #10: Weekday#1 Daily Profile	UINT16	0* to 19	
38	RW	Season #10: Weekday#2 Daily Profile	UINT16		
39	RW	Season #10: Weekday#3 Daily Profile	UINT16		
40	RW	Season #11: Start Date	UINT16	See Season #2: Start Date	
41	RW	Season #11: Weekday#1 Daily Profile	UINT16	0* to 19	
42	RW	Season #11: Weekday#2 Daily Profile	UINT16		
43	RW	Season #11: Weekday#3 Daily Profile	UINT16		
44	RW	Season #12: Start Date	UINT16	See Season #2: Start Date	
45	RW	Season #12: Weekday#1 Daily Profile	UINT16	0* to 19	
46	RW	Season #12: Weekday#2 Daily Profile	UINT16		
47	RW	Season #12: Weekday#3 Daily Profile	UINT16		

Table 5-125 Season Setting

Notes:

1. The **Start Date** for the first **Season** is programmable and defaults to 01/01 since firmware V2.50.03 (In firmware prior to V2.50.03, the **Start Date** for the **first Season** is fixed to 01/01 and cannot be changed).
2. Setting a Season’s **Start Date** as 0xFFFF terminates the TOU’s Season settings. All subsequent Seasons’ setup parameters will be ignored since the previous Season’s duration is from its **Start Date** to the end of the year.
3. The **Start Date** of a particular Season must be later than the previous Season’s.

5.17.22.3 Daily Profile Setting

The iMeter 7A has two sets of Daily Profile setup parameters, one for each TOU.

DP Set #1	DP Set #2	Property	Description	Format
50400~50423	50900~50923	RW	Daily Profile #1	See Table 5-127
50424~50447	50924~50947	RW	Daily Profile #2	
50448~50471	50948~50971	RW	Daily Profile #3	
50472~50495	50972~50995	RW	Daily Profile #4	
50496~50519	50996~51019	RW	Daily Profile #5	
50520~50543	51020~51043	RW	Daily Profile #6	
50544~50567	51044~51067	RW	Daily Profile #7	
50568~50591	51068~51091	RW	Daily Profile #8	

50592~50615	51092~50615	RW	Daily Profile #9
50616~50639	51116~51139	RW	Daily Profile #10
50640~50663	51140~51163	RW	Daily Profile #11
50664~50687	51164~51187	RW	Daily Profile #12
50688~50711	51188~51211	RW	Daily Profile #13
50712~50735	51212~51235	RW	Daily Profile #14
50736~50760	51236~51260	RW	Daily Profile #15
50760~50783	51260~51283	RW	Daily Profile #16
50784~50807	51284~51307	RW	Daily Profile #17
50808~50831	51308~51331	RW	Daily Profile #18
50832~50855	51332~51355	RW	Daily Profile #19
50856~50879	51356~51379	RW	Daily Profile #20

Table 5-126 Daily Profile#1 & #2 Setting

Offset	Property	Description	Format	Note
+0	RW	Period #1 Start Time	UINT16	0x0000
+1	RW	Period #1 Tariff	UINT16	0=T1, ..., 7=T8
+2	RW	Period #2 Start Time	UINT16	0 ≤ Hour < 24
				Min=0, 15, 30, 45
+3	RW	Period #2 Tariff	UINT16	0=T1, ..., 7=T8
+4	RW	Period #3 Start Time	UINT16	See Period #2 Start Time
+5	RW	Period #3 Tariff	UINT16	0=T1, ..., 7=T8
+6	RW	Period #4 Start Time	UINT16	See Period #2 Start Time
+7	RW	Period #4 Tariff	UINT16	0=T1, ..., 7=T8
+8	RW	Period #5 Start Time	UINT16	See Period #2 Start Time
+9	RW	Period #5 Tariff	UINT16	0=T1, ..., 7=T8
+10	RW	Period #6 Start Time	UINT16	See Period #2 Start Time
+11	RW	Period #6 Tariff	UINT16	0=T1, ..., 7=T8
+12	RW	Period #7 Start Time	UINT16	See Period #2 Start Time
+13	RW	Period #7 Tariff	UINT16	0=T1, ..., 7=T8
+14	RW	Period #8 Start Time	UINT16	See Period #2 Start Time
+15	RW	Period #8 Tariff	UINT16	0=T1, ..., 7=T8
+16	RW	Period #9 Start Time	UINT16	See Period #2 Start Time
+17	RW	Period #9 Tariff	UINT16	0=T1, ..., 7=T8
+18	RW	Period #10 Start Time	UINT16	See Period #2 Start Time
+19	RW	Period #10 Tariff	UINT16	0=T1, ..., 7=T8
+20	RW	Period #11 Start Time	UINT16	See Period #2 Start Time
+21	RW	Period #11 Tariff	UINT16	0=T1, ..., 7=T8
+22	RW	Period #12 Start Time	UINT16	See Period #2 Start Time
+23	RW	Period #12 Tariff	UINT16	0=T1, ..., 7=T8

Table 5-127 Daily Profile Data Structure Setup

Notes:

1. **Daily Profile #1's Period #1 Start Time** is always 00:00 and cannot be modified.
2. Setting a Period's **Start Time** as 0xFFFF terminates the Daily Profile's settings. All later Daily Profile's setup parameters will be ignored, and the previous Period's duration is from its **Start Time** to the end of the day.
3. The minimum interval of a period is 15 minutes.
4. The **Start Time** of a particular Period must be later than the previous Period's.

5.17.22.4 Alternate Day Setting

The Alternate Days have higher priority than the season, which means if one day is set as an alternate day, then this day's rate distribution will be according to the Alternate Days schedule.

The iMeter 7A has two sets of Alternate Days setup parameters, one for each TOU. The Base Addresses for the two sets are 51400 and 51700, respectively, where the Register Address = Base Address + Offset. For example, the register address for TOU #2's Alternate Day #2's Date is 51700+3 = 51703.

Offset	Property	Description	Format	Note, Default*
0	RW	Alternate Day #1 Date ¹	UINT32	See Notes 1)
2	RW	Alternate Day #1 Daily Profile	UINT16	0* to 19
3	RW	Alternate Day #2 Date ¹	UINT32	See Notes 1)
5	RW	Alternate Day #2 Daily Profile	UINT16	0* to 19
6	RW	Alternate Day #3 Date ¹	UINT32	See Notes 1)
8	RW	Alternate Day #3 Daily Profile	UINT16	0* to 19
9	RW	Alternate Day #4 Date ¹	UINT32	See Notes 1)
11	RW	Alternate Day #4 Daily Profile	UINT16	0* to 19
12	RW	Alternate Day #5 Date ¹	UINT32	See Notes 1)

14	RW	Alternate Day #5 Daily Profile	UINT16	0* to 19
15	RW	Alternate Day #6 Date ¹	UINT32	See Notes 1)
17	RW	Alternate Day #6 Daily Profile	UINT16	0* to 19
18	RW	Alternate Day #7 Date ¹	UINT32	See Notes 1)
19	RW	Alternate Day #7 Daily Profile	UINT16	0* to 19
21	RW	Alternate Day #8 Date ¹	UINT32	See Notes 1)
22	RW	Alternate Day #8 Daily Profile	UINT16	0* to 19
24	RW	Alternate Day #9 Date ¹	UINT32	See Notes 1)
25	RW	Alternate Day #9 Daily Profile	UINT16	0* to 19
27	RW	Alternate Day #10 Date ¹	UINT32	See Notes 1)
29	RW	Alternate Day #10 Daily Profile	UINT16	0* to 19
...		...		
240	RW	Alternate Day #81 Date ¹	UINT32	See Notes 1)
242	RW	Alternate Day #81 Daily Profile	UINT16	0* to 19
243	RW	Alternate Day #82 Date ¹	UINT32	See Notes 1)
245	RW	Alternate Day #82 Daily Profile	UINT16	0* to 19
246	RW	Alternate Day #83 Date ¹	UINT32	See Notes 1)
248	RW	Alternate Day #83 Daily Profile	UINT16	0* to 19
249	RW	Alternate Day #84 Date ¹	UINT32	See Notes 1)
251	RW	Alternate Day #84 Daily Profile	UINT16	0* to 19
252	RW	Alternate Day #85 Date ¹	UINT32	See Notes 1)
254	RW	Alternate Day #85 Daily Profile	UINT16	0* to 19
255	RW	Alternate Day #86 Date ¹	UINT32	See Notes 1)
256	RW	Alternate Day #86 Daily Profile	UINT16	0* to 19
258	RW	Alternate Day #87 Date ¹	UINT32	See Notes 1)
260	RW	Alternate Day #87 Daily Profile	UINT16	0* to 19
261	RW	Alternate Day #88 Date ¹	UINT32	See Notes 1)
263	RW	Alternate Day #88 Daily Profile	UINT16	0* to 19
264	RW	Alternate Day #89 Date ¹	UINT32	See Notes 1)
266	RW	Alternate Day #89 Daily Profile	UINT16	0* to 19
267	RW	Alternate Day #90 Date ¹	UINT32	See Notes 1)
269	RW	Alternate Day #90 Daily Profile	UINT16	0* to 19

Table 5-128 Alternate Days Setup

Notes:

1) The following table illustrates the data structure of the Date register:

Byte 3	Byte 2	Byte 1	Byte 0
Reserved	Year-2000 (0-37)	Month (1-12)	Day (1-31)

Table 5-129 Date Format

When the Year and/or Month are set as 0xFF, it means the Alternate Day is repetitive by year and/or month, i.e. the same day of every year or every month is an Alternate Day.

5.17.23 IEEE Std 519-2022 Report Setting

5.17.23.1 Basic Setting

Register	Property	Description	Format	Range/Option, Default*
52600	RW	IEEE Std 519 mode ¹	UINT16	0=Disable*, 1=Standard, 2=Custom
52601	RW	Enable HVDC ²	UINT16	0=No*, 1=Yes
52602	RW	Enable power generation facilities ³	UINT16	0=No*, 1=Yes
52603	RW	PCC Voltage ⁴	UINT32	1 to 9,999,000 (V), 415*
52605	RW	Max. Short Circuit Current ^{5,6}	UINT32	1 to 9,999,000 (A), 40,000*
52607	RW	First Day of Week	UINT16	0=Sunday*, 1~6=Monday to Saturday
52608	RW	Alert Notification	UINT16	1=Alarm Email*, 1=Periodic Email

Table 5-130 IEEE Std 519-2022 Report Setting Parameters

Notes:

1. The **Standard** and **Custom** modes for the IEEE Std 519 report determine the IL and limits for report generation.

Standard – Use measured IL for **SCR** calculation and determining the limits according to IEEE Std 519-2022 for report generation.

Custom – Use custom **TDD Preset IL** (see **Section 4.3.9.5**) for **SCR** calculation. User may customize the harmonic limits in **Section 5.17.23.2** for report generation.

In **Standard** mode, for a new installation, the monthly maximum current demand is not available.

- If Preset IL ≠ 0: the meter will use Preset IL for SCR calculation and determining the current harmonic distortion limits in the first month (M < 1),
- If Preset IL = 0: the meter will use the greater of **This Max. Current Demand** and **I Nominal*CT Ratio** for SCR cal. and for determining the current harmonic distortion limits in the first month (M < 1).

2. High-voltage systems (> 161kV) are allowed to have a higher voltage THD where the cause is an HVDC terminal. In this condition, enable the **HVDC** parameter to increase the voltage THD tolerance to 2% (see Table 4-21).
3. For power generation equipment, enable this parameter to limit the current distortion to those value in row for < 20 or < 25 group in Table 4-22, regardless of actual Isc/IL.
4. PCC Voltage = Ull Nominal x PT Ratio
5. This is the maximum short circuit current could be produced at PCC according to the PCC voltage and the supply impedance at PCC, rather than the maximum MCCB rating.
6. Modification of the **Max. Short Circuit Current** (Isc) may change the SCR (Isc/IL) ratio and result in a change in the harmonic current distortion limits.

5.17.23.2 IEEE Std 519-2022 Parameters

Register	Property	Description	Format	Scale/Unit, Default*
52610	RW	VTHD Limit	UINT32	800* (x0.01, %)
52612	RW	2 nd Harmonic Voltage Limit	UINT32	500* (x0.01, %)
52614	RW	3 rd Harmonic Voltage Limit	UINT32	500* (x0.01, %)
...	RW	...	UINT32	500* (x0.01, %)
52708	RW	50 th Harmonic Voltage Limit	UINT32	500* (x0.01, %)
52710-52714	--	Reserved	UINT32	--
52716	RW	TDD Limit	UINT32	2000* (x0.01, %)
52718	RW	2 nd Harmonic Current Limit	UINT32	1500* (x0.01, %)
52720	RW	3 rd Harmonic Current Limit	UINT32	1500* (x0.01, %)
...	RW	...	UINT32	
52734	RW	10 th Harmonic Current Limit	UINT32	1500* (x0.01, %)
52736	RW	11 th Harmonic Current Limit	UINT32	700* (x0.01, %)
52738	RW	12 th Harmonic Current Limit	UINT32	700* (x0.01, %)
...	RW	...	UINT32	700* (x0.01, %)
52746	RW	16 th Harmonic Current Limit	UINT32	700* (x0.01, %)
52748	RW	17 th Harmonic Current Limit	UINT32	600* (x0.01, %)
52750	RW	18 th Harmonic Current Limit	UINT32	600* (x0.01, %)
...	RW	...	UINT32	600* (x0.01, %)
52758	RW	22 nd Harmonic Current Limit	UINT32	600* (x0.01, %)
52760	RW	23 rd Harmonic Current Limit	UINT32	250* (x0.01, %)
52762	RW	24 th Harmonic Current Limit	UINT32	250* (x0.01, %)
...	RW	...	UINT32	250* (x0.01, %)
52782	RW	34 th Harmonic Current Limit	UINT32	250* (x0.01, %)
52784	RW	35 th Harmonic Current Limit	UINT32	140* (x0.01, %)
52786	RW	36 th Harmonic Current Limit	UINT32	140* (x0.01, %)
...	RW	...	UINT32	140* (x0.01, %)
52814	RW	50 th Harmonic Current Limit	UINT32	140* (x0.01, %)

Table 5-131 IEEE Std 519-2022 Parameters

5.18 Control Operation

5.18.1 Alarm/DO Control

The Alarm/DO Control registers are implemented as both “Write-Only” Modbus Coil Registers (0XXXXX) and Modbus Holding Registers (4XXXXX), which can be controlled with the Force Single Coil command (Function Code 0x05) or the Preset Multiple Hold Registers (Function Code 0x10). The iMeter 7A does not support the Read Coils command (Function Code 0x01) because Alarm/DO Control registers are “Write-Only”. The DO Status register 0310 should be read instead to determine the current DO status.

The iMeter 7A adopts the ARM before EXECUTE operation for the remote control of its Digital Outputs if this function is enabled through the **Arm Before Execute Enable** Setup register (40301), which is enabled by default. Before executing an OPEN or CLOSE command on a Relay Output, it must be “Armed” first. This is achieved by writing the value 0xFF00 to the appropriate register to “Arm” a particular DO operation. The DO will be “Disarmed” automatically if an “Execute” command is not received within 15 seconds after it has been “Armed”. If an “Execute” command is received without first having received an “Arm” command, the meter ignores the “Execute” command and returns the 0x04 exception code.

Register	Property	Description	Format	Note
9100	WO	Arm Alarm Close	UINT16	Writing “0xFF00”
9101	WO	Execute Alarm Close	UINT16	
9102	WO	Arm Alarm Open	UINT16	
9103	WO	Execute Alarm Open	UINT16	
9104	WO	Arm DO1 Close	UINT16	
9105	WO	Execute DO1 Close	UINT16	

9106	WO	Arm DO1 Open	UINT16
9107	WO	Execute DO1 Open	UINT16
9108	WO	Arm DO2 Close	UINT16
9109	WO	Execute DO2 Close	UINT16
9110	WO	Arm DO2 Open	UINT16
9111	WO	Execute DO2 Open	UINT16
9112	WO	Arm DO3 Close	UINT16
9113	WO	Execute DO3 Close	UINT16
9114	WO	Arm DO3 Open	UINT16
9115	WO	Execute DO3 Open	UINT16
9116	WO	Arm DO4 Close	UINT16
9117	WO	Execute DO4 Close	UINT16
9118	WO	Arm DO4 Open	UINT16
9119	WO	Execute DO4 Open	UINT16

Table 5-132 DO Control

5.18.2 Clear/Manual Trigger Operation

Register	Property	Description	Format	Note
9200	WO	Send Test Email ¹	UINT16	Writing "0xFF00" to the register to execute the described action.
9201	WO	Clear DI1 Counter	UINT16	
9202	WO	Clear DI2 Counter	UINT16	
9203	WO	Clear DI3 Counter	UINT16	
9204	WO	Clear DI4 Counter	UINT16	
9205	WO	Clear DI5 Counter	UINT16	
9206	WO	Clear DI6 Counter	UINT16	
9207	WO	Clear DI7 Counter	UINT16	
9208	WO	Clear DI8 Counter	UINT16	
9209~9216	--	Reserved	UINT16	
9217	WO	Clear All DI Counters	UINT16	
9218	WO	Reset All DOs to Normal	UINT16	
9219	WO	Clear All Data ²	UINT16	
9220~9252	--	Reserved	--	
9253	WO	Manual Trigger WFR	UINT16	
9254	WO	Manual Trigger RMSR	UINT16	
9255	WO	Manual Trigger DWR	UINT16	
9256	WO	Manual Freeze TOU Log	UINT16	
9257	WO	Manual Trigger TOU Recording	UINT16	
9258	WO	Manual Switch TOU Schedules	UINT16	
9259	WO	Manually trigger iTrigger 1	UINT16	
9260	WO	Manually trigger iTrigger 2	UINT16	
9261	WO	Manually trigger iTrigger 3	UINT16	
9262	WO	Reset IL ³	UINT16	
9263	WO	Clear Energy Registers ⁴	UINT16	
9264	WO	Clear 3-phase Total AER Log	UINT16	
9265	WO	Clear 3-phase Total IER Log	UINT16	
9266	WO	Clear Per-phase AER Log	UINT16	
9267	WO	Clear Per-phase IER Log	UINT16	
9268-9274	--	Reserved	--	
9275	WO	Clear Plt Log	UINT16	
9276	WO	Clear Pst Log	UINT16	
9277	WO	Clear WFR	UINT16	
9278	WO	Clear DWR	UINT16	
9279~9281	WO	Reserved	UINT16	
9282	WO	Clear All MM Log ⁵	UINT16	
9283	WO	Clear This Max. Log	UINT16	
9284	WO	Clear This Min. Log	UINT16	
9285~9292	--	Reserved	--	
9293	WO	Clear All Demand ⁶	UINT16	
9294	WO	Clear This Max. Demand Log ⁷	UINT16	
9295	WO	Clear EN 50160 Log	UINT16	
9296	WO	Reserved	UINT16	
9297	WO	Clear SDR Log #1	UINT16	
9298	WO	Clear SDR Log #2	UINT16	
9299	WO	Clear SDR Log #3	UINT16	
9300	WO	Clear SDR Log #4	UINT16	
9301	WO	Clear SDR Log #5	UINT16	

9302	WO	Clear SDR Log #6	UINT16
9303	WO	Clear SDR Log #7	UINT16
9304	WO	Clear SDR Log #8	UINT16
9305~9312	--	Reserved	--
9313	WO	Clear All SDR Logs	UINT16
9314	WO	Clear DR Log #1	UINT16
9315	WO	Clear DR Log #2	UINT16
9316	WO	Clear DR Log #3	UINT16
9317	WO	Clear DR Log #4	UINT16
9318	WO	Clear DR Log #5	UINT16
9319	WO	Clear DR Log #6	UINT16
9320	WO	Clear DR Log #7	UINT16
9321	WO	Clear DR Log #8	UINT16
9322	WO	Clear All DR Logs	UINT16
9323~9326	--	Reserved	--
9327	WO	Clear Operating Time	UINT16
9328~9331	--	Reserved	--
9332	WO	Clear Dip Counter	UINT16
9333	WO	Clear Swell Counter	UINT16
9334	WO	Clear Interruption Counter	UINT16
9335	WO	Clear Transient Counter	UINT16
9336	WO	Clear RVC Counter	UINT16
9337	WO	Clear Inrush Current Counter	UINT16
9338	WO	Reserved	UINT16
9339	WO	Clear MSV#1 Counter	UINT16
9340	WO	Clear MSV#2 Counter	UINT16
9341	WO	Clear MSV#3 Counter	UINT16
9342	WO	Clear All PQ Counter	UINT16
9343	WO	Clear All TOU Data	UINT16
9344	WO	Trigger Demo Swell Event	UINT16
9345	WO	Trigger Demo Dip Event	UINT16
9346	WO	Trigger Demo Interruption Event	UINT16
9347	WO	Trigger Demo Transient Event	UINT16
9348	WO	Trigger Demo Inrush Current Event	UINT16
9349	WO	Trigger Demo RVC Event	UINT16
9350	WO	Trigger Demo Motor start Event	UINT16
9351	WO	Clear RMSR Log	UINT16
9352	WO	Clear IEEE Std 519-2022 Reports	--
9353	WO	Clear All Events	UINT16
9354	--	Reserved	--
9355	WO	Clear 2k-150kHz C.E. Records	UINT16
9356	WO	Clear Device Log	UINT16
9357	WO	Clear SOE Log	UINT16

Table 5-133 Clear/Manual Trigger Operation

Notes:

1. The **Send Test Email** register can verify if the SMTP functions normally providing the SMTP configurations are correct.
2. Writing 0xFF00 to the Clear All Data register will clear all the data stored in iMeter 7A and reboot the meter.
3. Before a new round commissioning test after installation, it is recommended to perform the Clear All Demands and Reset IL to clear the historical demand and IL record for generating a report for verification purpose.
4. Writing 0xFF00 to the Clear Energy Register will clear all 3-Phase Total Energy measurements (INT32 & INT64), Per-phase Energy measurements (INT32 & INT64), and Harmonic Energy measurements (INT32 & INT64).
5. Writing 0xFF00 to the Clear All MM Log register will clear all Max./Min. Logs (Max Demand Logs are excluded).
6. Writing 0xFF00 to the Clear All Demand register to clear the Present/Predicated Demand, as well as This Max./Last Max. Demand.
7. Writing 0xFF00 to the Clear This Max. Demand Log register to clear Max. Demand Log of This Month (Since Last Reset) when the Self-Read Time register is set for automatic Self-Read operation. The Max. Demand of Last Month will not be cleared. If the Self-Read Time register is set for manual operation with a register value of 0xFFFF, the Peak Demand of This Month (Since Last Reset) will be transferred to the Peak Demand of Last Month (Before Last Reset) and then cleared.

5.19 Time Register

There are two sets of Time registers supported by the iMeter 7A - Year/Month/Day/Hour/Minute/Second (Registers # 60000 to 60003 for 6-digit addressing and Registers # 9000 to 9003 for 5-digit addressing) and UNIX Time (Registers # 60004 to 60005 for 6-digit addressing and Registers # 9004 to 9005 for 5-digit addressing). When sending time to the iMeter 7A over Modbus communications, care should be taken to only write one of the two Time register sets. All registers within a Time register set must be written in a single transaction. If registers 60000 to 60003 (or 9000 to 9003 for 5-digit addressing) are

being written to at the same time, both Time register sets will be updated to reflect the new time specified in the UNIX Time register set 60004 (9004) where the time specified in registers 60000 to 60003 (9000-9003 for 5-digit addressing) will be ignored. When broadcasting time, the function code must be set to 0x10 (Pre-set Multiple Registers). Incorrect date or time values will be rejected by the meter.

Register	Property	Description	Format	Note
60000	9000	RW	UINT16	High-order Byte: Year
		Low-order Byte: Month		
60001	9001	RW	UINT16	High-order Byte: Day
		Low-order Byte: Hour		
60002	9002	RW	UINT16	High-order Byte: Minute
		Low-order Byte: Second		
60003	9003	RW	UINT16	Millisecond
60004 ~ 60005	9004 ~ 9005	RW	UINT32	UNIX Time 0x386D4380 to 0x7FE8177F The corresponding time is 2000.01.01 00:00:00 to 2037.12.31 23:59:59 (GMT 0:00 Time Zone)

Table 5-134 Time Registers

5.20 Information

5.20.1 Substation Information

Register	Property	Description	Format	Default
40600	RW	Supply Company Tag 1	CHAR	devTag 0
40630	RW	Supply Company Tag 2	CHAR	devTag 1
40660	RW	Substation Name	CHAR	devTag 2
40690	RW	Voltage Level	CHAR	devTag 3
4072~40749	RW	IEC 61850 IED Name (Less than 60 characters)	CHAR	Null

Table 5-135 Substation Information

5.20.2 Site Information

Register	Property	Description	Format	Default
52000	RW	Circuit Name (Less than 16 characters)	CHAR	circuitN
52008	RW	Bus Name	CHAR	circuitTag 0
52038	RW	Station Name	CHAR	circuitTag 1
52068	RW	Station Voltage Level	CHAR	circuitTag 2
52098	RW	Assets Management ID	CHAR	circuitTag 3
52128	RW	Monitoring Network ID	CHAR	circuitTag 4
52158	RW	Commissioning Date	CHAR	circuitTag 5
52188	RW	Exclusive Use (Yes/No)	CHAR	circuitTag 6
52218	RW	Short-circuit Capacity	CHAR	circuitTag 7
52248	RW	Power Supply Capacity	CHAR	circuitTag 8
52278	RW	Customer Usage Agreement	CHAR	circuitTag 9
52308	RW	COMTRADE Tag (Less than 60 characters)	CHAR	Null

Table 5-136 Circuit Information

5.20.3 Device Information

Register	Property	Description	Format	Note
60200~60219	9800~9819	RO	CHAR	Meter Model
60220	9820	RO	UINT16	Firmware Version
60221	9821	RO	UINT16	Modbus Version
60222	9822	RO	UINT16	IEC 61850 Version
60223	9823	RO	UINT16	Hardware Version
60224	9824	RO	UINT16	Firmware Date: Year-2000
60225	9825	RO	UINT16	Firmware Date: Month
60226	9826	RO	UINT16	Firmware Date: Day
60227	9827	RO	UINT32	Serial Number
60229	9829	--	--	Reserved
60230	9830	RO	BITMAP	Feature Code
60232	9832	--	--	Reserved
60233	9833	RO	FLOAT	Device Temperature
60235	9835	RO	BITMAP	PPC Diagnostics Info.

					BIT2~BIT6: Reserved BIT7: NVRMA BIT8: Memory BIT9: DSP BIT10: ADC 0=Normal, 1=Error
60237	9837	--	Reserved	--	
60239	9839	RO	Time Sync. Status	UINT16	0=Unsync., 1=Synced., 2=Syncing.
60241	9841	--	Reserved	--	
60243	9843	RO	P1 MAC Address-01	UINT16	0x00A0
60244	9844	RO	P1 MAC Address-23	UINT16	0x1EA0
60245	9845	RO	P1 MAC Address-45	UINT16	0xAAA0
60246	9846	RO	P2 MAC Address-01	UINT16	0x00A0
60247	9847	RO	P2 MAC Address-23	UINT16	0x1EA1
60248	9848	RO	P2 MAC Address-45	UINT16	0xAAA0
60249	9849	RO	Memory Capacity	UINT16	Units: MB
60250	9850	RO	Remaining Memory	UINT16	Units: MB

Table 5-137 Meter Information

Notes:

1. The **Meter Model** appears in registers 60200 to 60219 and contains the ASCII encoding of the string “iMeter 7A” as shown in the following table.

Register	Value(Hex)	ANSII	
60200	9800	0x69	i
60201	9801	0x4D	M
60202	9802	0x65	e
60203	9803	0x74	t
60204	9804	0x65	e
60205	9805	0x72	r
60206	9806	0x20	Space
60207	9807	0x37	7
60208	9808	0x41	A
60209-60219	9809-9819	0x00	Null

Table 5-138 ASCII Coding for “iMeter 7A”

2. The **Feature Code** details are illustrated in the following table.

BIT	Descriptions	Value (BIN)	Meaning	Product Code
BIT1 BIT0	Basic Feature	00	IEC 61000-4-30 Ed. 3.1 Class A Certified with 2kHz-9kHz C.E. Measurement	A
		01	IEC 61000-4-30 Ed. 3.1 Class A Certified with 2kHz-150kHz C.E. Measurement	B
BIT4 BIT3 BIT2	Input Current	000	5A	5
		001	1A	1
		010	SCCP Option for use with CT Clamps with max. 500mV output	SCCPA
		011	For use with 100A/200A/400A/800A/1600A to 40mA SCCTs	SCCT
		100	For use with 5A/2mA SCCT	SCCTA
BIT7 BIT6 BIT5	Input Voltage	000	400VLN/690VLL + 20%	9
BIT9 BIT8	Power Supply	00	95 - 250VAC/DC ± 10%, 47 - 440Hz	2
		01	20 - 60VDC	3
BIT12 BIT11 BIT10	System Frequency	000	50Hz	5
		001	60Hz	6
BIT15 BIT14 13	I/O	000	4DI + 3DO	A
		001	4DI + 1DO + 2SS	B
		010	8DI + 5DO + 2AI	C
		011	8DI + 5DO + 2RTD	D
BIT17 BIT16	Reserved			
BIT20 BIT19 BIT18	Communication	000	2x10Base-T/100Base-TX + 1xRS-485	A
BIT22 BIT21	Display Language	00	English	E

Table 5-139 Feature Code Details

5.20.4 Communication Status

Register	Property	Description	Format	Range
60400	RO	Present P1 IP Address	UINT32	
60402	RO	Present P1 Subnet Mask	UINT32	
60404	RO	Present P2 IP Address	UINT32	
60406	RO	Present P2 Subnet Mask	UINT32	
60408	RO	Present Default Gateway	UINT32	
60410	RO	P1 Connection Status	UINT16	0=Disconnected, 1=Connected
60411	RO	P2 Connection Status	UINT16	0=Disconnected, 1=Connected

Table 5-140 Communication Status

Appendix A – Source Parameters for SDR, DR and Max./Min. Recorders

The iMeter 7A provides the following parameters with different aggregation interval of 50-cycle (1s), 150-cycle (3s), 10-min or 2-hour. For SDR and Max./Min Recorders, the parameters with 150 cycles are available. And for DR, the parameters with 50 cycles are available.

Key ID				Parameter	Key ID				Parameter
50-cycle	150-cycle	10-min	2-hour		50-cycle	150-cycle	10-min	2-hour	
1	10001	20001	30001	Freq.	1715	11715	21715	31715	P TH
2	10002	20002	30002	Ua	1716	11716	21716	31716	Q TH
3	10003	20003	30003	Ub	1717	11717	21717	31717	S TH
4	10004	20004	30004	Uc	1718	11718	21718	31718	PF Avg. TH
5	10005	20005	30005	U4	1719	11719	21719	31719	P Fund.
6	10006	20006	30006	Uln Avg.	1720	11720	21720	31720	Q Fund.
7	10007	20007	30007	Uab	1721	11721	21721	31721	S Fund.
8	10008	20008	30008	Ubc	1722	11722	21722	31722	dPF
9	10009	20009	30009	Uca	1723	11723	21723	31723	P H02
10	10010	20010	30010	Ull Avg.	1724	11724	21724	31724	Q H02
11	10011	20011	30011	Ia	1725	11725	21725	31725	S H02
12	10012	20012	30012	Ib	1726	11726	21726	31726	PF Avg. H02
13	10013	20013	30013	Ic	1727	11727	21727	31727	P H03
14	10014	20014	30014	I4	1728	11728	21728	31728	Q H03
--	--	--	--	Reserved	1729	11729	21729	31729	S H03
16	10016	20016	30016	I Avg.	1730	11730	21730	31730	PF Avg.H03
17	10017	20017	30017	Pa
18	10018	20018	30018	Pb	1963	11963	21963	31963	P H62
19	10019	20019	30019	Pc	1964	11964	21964	31964	Q H62
20	10020	20020	30020	P Total	1965	11965	21965	31965	S H62
21	10021	20021	30021	Qa	1966	11966	21966	31966	PF Avg. H62
22	10022	20022	30022	Qb	1967	11967	21967	31967	P H63
23	10023	20023	30023	Qc	1968	11968	21968	31968	Q H63
24	10024	20024	30024	Q Total	1969	11969	21969	31969	S H63
25	10025	20025	30025	Sa	1970	11970	21970	31970	PF Avg.H63
26	10026	20026	30026	Sb	1971	11971	21971	31971	Pa Fund.
27	10027	20027	30027	Sc	1972	11972	21972	31972	Pb Fund.
28	10028	20028	30028	S	1973	11973	21973	31973	Pc Fund.
29	10029	20029	30029	PFa	1974	11974	21974	31974	Qa Fund.
30	10030	20030	30030	PFb	1975	11975	21975	31975	Qb Fund.
31	10031	20031	30031	PFc	1976	11976	21976	31976	Qc Fund.
32	10032	20032	30032	PF Avg.	1977	11977	21977	31977	Sa Fund.
33	10033	20033	30033	Ua Dev.	1978	11978	21978	31978	Sb Fund.
34	10034	20034	30034	Ub Dev.	1979	11979	21979	31979	Sc Fund.
35	10035	20035	30035	Uc Dev.	1980	11980	21980	31980	dPFa
36	10036	20036	30036	Uab Dev.	1981	11981	21981	31981	dPFb
37	10037	20037	30037	Ubc Dev.	1982	11982	21982	31982	dPFc
38	10038	20038	30038	Uca Dev.	1983	11983	21983	31983	Pa H02
39	10039	20039	30039	Ua Over Dev.	1984	11984	21984	31984	Pb H02
40	10040	20040	30040	Ub Over Dev.	1985	11985	21985	31985	Pc H02
41	10041	20041	30041	Uc Over Dev.	1986	11986	21986	31986	Qa H02
42	10042	20042	30042	Uab Over Dev.	1987	11987	21987	31987	Qb H02
43	10043	20043	30043	Ubc Over Dev.	1988	11988	21988	31988	Qc H02
44	10044	20044	30044	Uca Over Dev.	1989	11989	21989	31989	Sa H02
45	10045	20045	30045	Ua Under Dev.	1990	11990	21990	31990	Sb H02
46	10046	20046	30046	Ub Under Dev.	1991	11991	21991	31991	Sc H02
47	10047	20047	30047	Uc Under Dev.	1992	11992	21992	31992	PFa H02
48	10048	20048	30048	Uab Under Dev.	1993	11993	21993	31993	PFb H02
49	10049	20049	30049	Ubc Under Dev.	1994	11994	21994	31994	PFc H02
50	10050	20050	30050	Uca Under Dev.
51	10051	20051	30051	Freq. Dev.	2715	12715	22715	32715	Pa H63
--	--	--	--	Reserved	2716	12716	22716	32716	Pb H63
55	10055	20055	30055	U0 Unb.	2717	12717	22717	32717	Pc H63
56	10056	20056	30056	U2 Unb.	2718	12718	22718	32718	Qa H63
57	10057	20057	30057	I0 Unb.	2719	12719	22719	32719	Qb H63
58	10058	20058	30058	I2 Unb.	2720	12720	22720	32720	Qc H63
59	10059	20059	30059	U0	2721	12721	22721	32721	Sa H63
60	10060	20060	30060	U2	2722	12722	22722	32722	Sb H63
61	10061	20061	30061	U1	2723	12723	22723	32723	Sc H63
62	10062	20062	30062	I0	2724	12724	22724	32724	PFa H63
63	10063	20063	30063	I2	2725	12725	22725	32725	PFb H63
64	10064	20064	30064	I1	2726	12726	22726	32726	PFc H63
65	10065	20065	30065	Ia TDD	2727	12727	22727	32727	Ua TIHD

CET Electric Technology

66	10066	20066	30066	Ib TDD	2728	12728	22728	32728	Ub TIHD
67	10067	20067	30067	Ic TDD	2729	12729	22729	32729	Uc TIHD
68	10068	20068	30068	I4 TDD	2730	12730	22730	32730	U4 TIHD
--	--	--	--	Reserved	2731	12731	22731	32731	Ua TOIHD
70	10070	20070	30070	Ia TDD Odd	2732	12732	22732	32732	Ub TOIHD
71	10071	20071	30071	Ib TDD Odd	2733	12733	22733	32733	Uc TOIHD
72	10072	20072	30072	Ic TDD Odd	2734	12734	22734	32734	U4 TOIHD
73	10073	20073	30073	I4 TDD Odd	2735	12735	22735	32735	Ua TEIHD
--	--	--	--	Reserved	2736	12736	22736	32736	Ub TEIHD
75	10075	20075	30075	Ia TDD Even	2737	12737	22737	32737	Uc TEIHD
76	10076	20076	30076	Ib TDD Even	2738	12738	22738	32738	U4 TEIHD
77	10077	20077	30077	Ic TDD Even	2739	12739	22739	32739	Ia TIHD
78	10078	20078	30078	I4 TDD Even	2740	12740	22740	32740	Ib TIHD
--	--	--	--	Reserved	2741	12741	22741	32741	Ic TIHD
80	10080	20080	30080	Ia K-Factor	2742	12742	22742	32742	I4 TIHD
81	10081	20081	30081	Ib K-Factor	--	--	--	--	Reserved
82	10082	20082	30082	Ic K-Factor	2744	12744	22744	32744	Ia TOIHD
83	10083	20083	30083	I4 K-Factor	2745	12745	22745	32745	Ib TOIHD
--	--	--	--	Reserved	2746	12746	22746	32746	Ic TOIHD
85	10085	20085	30085	Ia Crest Factor	2747	12747	22747	32747	I4 TOIHD
86	10086	20086	30086	Ib Crest Factor	--	--	--	--	Reserved
87	10087	20087	30087	Ic Crest Factor	2749	12749	22749	32749	Ia TEIHD
88	10088	20088	30088	I4 Crest Factor	2750	12750	22750	32750	Ib TEIHD
--	--	--	--	Reserved	2751	12751	22751	32751	Ic TEIHD
90	10090	20090	30090	Ua Crest Factor	2752	12752	22752	32752	I4 TEIHD
91	10091	20091	30091	Ub Crest Factor	--	--	--	--	Reserved
92	10092	20092	30092	Uc Crest Factor	2754	12754	22754	32754	Ua IHD00
93	10093	20093	30093	U4 Crest Factor	2755	12755	22755	32755	Ub IHD00
94	10094	20094	30094	Ua MSV #1	2756	12756	22756	32756	Uc IHD00
95	10095	20095	30095	Ub MSV #1	2757	12757	22757	32757	U4 IHD00
96	10096	20096	30096	Uc MSV #1	2758	12758	22758	32758	Ua IHD01
97	10097	20097	30097	Ua MSV #2	2759	12759	22759	32759	Ub IHD01
98	10098	20098	30098	Ub MSV #2	2760	12760	22760	32760	Uc IHD01
99	10099	20099	30099	Uc MSV #2	2761	12761	22761	32761	U4 IHD01
100	10100	20100	30100	Ua MSV #3
101	10101	20101	30101	Ub MSV #3	3006	13006	23006	33006	Ua IHD63
102	10102	20102	30102	Uc MSV #3	3007	13007	23007	33007	Ub IHD63
103	10103	20103	30103	Ua THD	3008	13008	23008	33008	Uc IHD63
104	10104	20104	30104	Ub THD	3009	13009	23009	33009	U4 IHD63
105	10105	20105	30105	Uc THD	3010	13010	23010	33010	Ia IHD00
106	10106	20106	30106	U4 THD	3011	13011	23011	33011	Ib IHD00
107	10107	20107	30107	Ua TOHD	3012	13012	23012	33012	Ic IHD00
108	10108	20108	30108	Ub TOHD	3013	13013	23013	33013	I4 IHD00
109	10109	20109	30109	Uc TOHD	--	--	--	--	Reserved
110	10110	20110	30110	U4 TOHD	3015	13015	23015	33015	Ia IHD01
111	10111	20111	30111	Ua TEHD	3016	13016	23016	33016	Ib IHD01
112	10112	20112	30112	Ub TEHD	3017	13017	23017	33017	Ic IHD01
113	10113	20113	30113	Uc TEHD	3018	13018	23018	33018	I4 IHD01
114	10114	20114	30114	U4 TEHD	--	--	--	--	Reserved
115	10115	20115	30115	Ia THD
116	10116	20116	30116	Ib THD	3325	13325	23325	33325	Ia IHD63
117	10117	20117	30117	Ic THD	3326	13326	23326	33326	Ib IHD63
118	10118	20118	30118	I4 THD	3327	13327	23327	33327	Ic IHD63
--	--	--	--	Reserved	3328	13328	23328	33328	I4 IHD63
120	10120	20120	30120	Ia TOHD	--	--	--	--	Reserved
121	10121	20121	30121	Ib TOHD	3330	13330	23330	33330	Ua TIH RMS
122	10122	20122	30122	Ic TOHD	3331	13331	23331	33331	Ub TIH RMS
123	10123	20123	30123	I4 TOHD	3332	13332	23332	33332	Uc TIH RMS
--	--	--	--	Reserved	3333	13333	23333	33333	U4 TIH RMS
125	10125	20125	30125	Ia TEHD	3334	13334	23334	33334	Ua TOIH RMS
126	10126	20126	30126	Ib TEHD	3335	13335	23335	33335	Ub TOIH RMS
127	10127	20127	30127	Ic TEHD	3336	13336	23336	33336	Uc TOIH RMS
128	10128	20128	30128	I4 TEHD	3337	13337	23337	33337	U4 TOIH RMS
--	--	--	--	Reserved	3338	13338	23338	33338	Ua TEIH RMS
130	10130	20130	30130	Uab Fund.	3339	13339	23339	33339	Ub TEIH RMS
131	10131	20131	30131	Ubc Fund.	3340	13340	23340	33340	Uc TEIH RMS
132	10132	20132	30132	Uca Fund.	3341	13341	23341	33341	U4 TEIH RMS
--	--	--	--	Reserved	3342	13342	23342	33342	Ia TIH RMS
450	10450	20450	30450	P Fund. +ve Seq.	3343	13343	23343	33343	Ib TIH RMS
451	10451	20451	30451	Q Fund. +ve Seq.	3344	13344	23344	33344	Ic TIH RMS
452	10452	20452	30452	S Unb.	3345	13345	23345	33345	I4 TIH RMS
453	10453	20453	30453	S Harmonic	--	--	--	--	Reserved
454	10454	20454	30454	In	3347	13347	23347	33347	Ia TOIH RMS

CET Electric Technology

455	10455	20455	30455	S Fund. +ve Seq.	3348	13348	23348	33348	Ib TOIH RMS
456	10456	20456	30456	S Non-Fund. Equal.	3349	13349	23349	33349	Ic TOIH RMS
457	10457	20457	30457	S Equal.	3350	13350	23350	33350	I4 TOIH RMS
458	10458	20458	30458	S Fund. Equal.	--	--	--	--	Reserved
459	10459	20459	30459	P Harmonic	3352	13352	23352	33352	Ia TEIH RMS
460	10460	20460	30460	Q HD	3353	13353	23353	33353	Ib TEIH RMS
461	10461	20461	30461	Q IHD	3354	13354	23354	33354	Ic TEIH RMS
462	10462	20462	30462	Q UHD	3355	13355	23355	33355	I4 TEIH RMS
--	--	--	--	Reserved	--	--	--	--	Reserved
500	10500	20500	30500	Ua HD00	3357	13357	23357	33357	Ua IH00 RMS
501	10501	20501	30501	Ub HD00	3358	13358	23358	33358	Ub IH00 RMS
502	10502	20502	30502	Uc HD00	3359	13359	23359	33359	Uc IH00 RMS
503	10503	20503	30503	U4 HD00	3360	13360	23360	33360	U4 IH00 RMS
504	10504	20504	30504	Ua HD01	3361	13361	23361	33361	Ua IH01 RMS
505	10505	20505	30505	Ub HD01	3362	13362	23362	33362	Ub IH01 RMS
506	10506	20506	30506	Uc HD01	3363	13363	23363	33363	Uc IH01 RMS
507	10507	20507	30507	U4 HD01	3364	13364	23364	33364	U4 IH01 RMS
...
748	10748	20748	30748	Ua HD62	3609	13609	23609	33609	Ua IH63 RMS
749	10749	20749	30749	Ub HD62	3610	13610	23610	33610	Ub IH63 RMS
750	10750	20750	30750	Uc HD62	3611	13611	23611	33611	Uc IH63 RMS
751	10751	20751	30751	U4 HD62	3612	13612	23612	33612	U4 IH63 RMS
752	10752	20752	30752	Ua HD63	3613	13613	23613	33613	Ia IH00 RMS
753	10753	20753	30753	Ub HD63	3614	13614	23614	33614	Ib IH00 RMS
754	10754	20754	30754	Uc HD63	3615	13615	23615	33615	Ic IH00 RMS
755	10755	20755	30755	U4 HD63	3616	13616	23616	33616	I4 IH00 RMS
756	10756	20756	30756	Ia HD00	--	--	--	--	Reserved
757	10757	20757	30757	Ib HD00	3618	13618	23618	33618	Ia IH01 RMS
758	10758	20758	30758	Ic HD00	3619	13619	23619	33619	Ib IH01 RMS
759	10759	20759	30759	I4 HD00	3620	13620	23620	33620	Ic IH01 RMS
--	--	--	--	Reserved	3621	13621	23621	33621	I4 IH01 RMS
761	10761	20761	30761	Ia HD01	--	--	--	--	Reserved
762	10762	20762	30762	Ib HD01
763	10763	20763	30763	Ic HD01	3928	13928	23928	33928	Ia IH63 RMS
764	10764	20764	30764	I4 HD01	3929	13929	23929	33929	Ib IH63 RMS
--	--	--	--	Reserved	3930	13930	23930	33930	Ic IH63 RMS
...	3931	13931	23931	33931	I4 IH63 RMS
1066	11066	21066	31066	Ia HD62	--	--	--	--	Reserved
1067	11067	21067	31067	Ib HD62	3933	13933	23933	33933	Ua Angle
1068	11068	21068	31068	Ic HD62	3934	13934	23934	33934	Ub Angle
1069	11069	21069	31069	I4 HD62	3935	13935	23935	33935	Uc Angle
--	--	--	--	Reserved	3936	13936	23936	33936	U4 Angle
1071	11071	21071	31071	Ia HD63	3937	13937	23937	33937	Ia Angle
1072	11072	21072	31072	Ib HD63	3938	13938	23938	33938	Ib Angle
1073	11073	21073	31073	Ic HD63	3939	13939	23939	33939	Ic Angle
1074	11074	21074	31074	I4 HD63	3940	13940	23940	33940	I4 Angle
--	--	--	--	Reserved	--	--	--	--	Reserved
1076	11076	21076	31076	Ua TH RMS	3942	13942	23942	33942	Ua Fund. Angle
1077	11077	21077	31077	Ub TH RMS	3943	13943	23943	33943	Ub Fund. Angle
1078	11078	21078	31078	Uc TH RMS	3944	13944	23944	33944	Uc Fund. Angle
1079	11079	21079	31079	U4 TH RMS	3945	13945	23945	33945	U4 Fund. Angle
1080	11080	21080	31080	Ua TOH RMS	3946	13946	23946	33946	Ua H02 Angle
1081	11081	21081	31081	Ub TOH RMS	3947	13947	23947	33947	Ub H02 Angle
1082	11082	21082	31082	Uc TOH RMS	3948	13948	23948	33948	Uc H02 Angle
1083	11083	21083	31083	U4 TOH RMS	3949	13949	23949	33949	U4 H02 Angle
1084	11084	21084	31084	Ua TEH RMS
1085	11085	21085	31085	Ub TEH RMS	4190	14190	24190	34190	Ua H63 Angle
1086	11086	21086	31086	Uc TEH RMS	4191	14191	24191	34191	Ub H63 Angle
1087	11087	21087	31087	U4 TEH RMS	4192	14192	24192	34192	Uc H63 Angle
1088	11088	21088	31088	Ia TH RMS	4193	14193	24193	34193	U4 H63 Angle
1089	11089	21089	31089	Ib TH RMS	4194	14194	24194	34194	Ia Fund. Angle
1090	11090	21090	31090	Ic TH RMS	4195	14195	24195	34195	Ib Fund. Angle
1091	11091	21091	31091	I4 TH RMS	4196	14196	24196	34196	Ic Fund. Angle
--	--	--	--	Reserved	4197	14197	24197	34197	I4 Fund. Angle
1093	11093	21093	31093	Ia TOH RMS	--	--	--	--	Reserved
1094	11094	21094	31094	Ib TOH RMS	4199	14199	24199	34199	Ia H02 Angle
1095	11095	21095	31095	Ic TOH RMS	4200	14200	24200	34200	Ib H02 Angle
1096	11096	21096	31096	I4 TOH RMS	4201	14201	24201	34201	Ic H02 Angle
--	--	--	--	Reserved	4202	14202	24202	34202	I4 H02 Angle
1098	11098	21098	31098	Ia TEH RMS	--	--	--	--	Reserved
1099	11099	21099	31099	Ib TEH RMS
1100	11100	21100	31100	Ic TEH RMS	4504	14504	24504	34504	Ia H63 Angle
1101	11101	21101	31101	I4 TEH RMS	4505	14505	24505	34505	Ib H63 Angle

CET Electric Technology

--	--	--	--	Reserved	4506	14506	24506	34506	Ic H63 Angle
1103	11103	21103	31103	Ua DC Component	4507	14507	24507	34507	I4 H63 Angle
1104	11104	21104	31104	Ub DC Component	--	--	--	--	Reserved
1105	11105	21105	31105	Uc DC Component	5000	15000	25000	35000	Uab DC Component
1106	11106	21106	31106	U4 DC Component	5001	15001	25001	35001	Ubc DC Component
1107	11107	21107	31107	Ua Fund.	5002	15002	25002	35002	Uca DC Component
1108	11108	21108	31108	Ub Fund.	5003	15003	25003	35003	Uab Fund.
1109	11109	21109	31109	Uc Fund.	5004	15004	25004	35004	Ubc Fund.
1110	11110	21110	31110	U4 Fund.	5005	15005	25005	35005	Uca Fund.
1111	11111	21111	31111	Ua H02 RMS
1112	11112	21112	31112	Ub H02 RMS	5189	15189	25189	35189	Uab H63 RMS
1113	11113	21113	31113	Uc H02 RMS	5190	15190	25190	35190	Ubc H63 RMS
1114	11114	21114	31114	U4 H02 RMS	5191	15191	25191	35191	Uca H63 RMS
1115	11115	21115	31115	Ua H03 RMS	5192	15192	25192	35192	Uab HD00
1116	11116	21116	31116	Ub H03 RMS	5193	15193	25193	35193	Ubc HD00
1117	11117	21117	31117	Uc H03 RMS	5194	15194	25194	35194	Uca HD00
1118	11118	21118	31118	U4 H03 RMS	5195	15195	25195	35195	Uab HD01
...	5196	15196	25196	35196	Ubc HD01
1351	11351	21351	31351	Ua H62 RMS	5197	15197	25197	35197	Uca HD01
1352	11352	21352	31352	Ub H62 RMS
1353	11353	21353	31353	Uc H62 RMS	5381	15381	25381	35381	Uab HD63
1354	11354	21354	31354	U4 H62 RMS	5382	15382	25382	35382	Ubc HD63
1355	11355	21355	31355	Ua H63 RMS	5383	15383	25383	35383	Uca HD63
1356	11356	21356	31356	Ub H63 RMS	--	--	--	--	Reserved
1357	11357	21357	31357	Uc H63 RMS	5390	15390	25390	35390	Uab IH02 RMS
1358	11358	21358	31358	U4 H63 RMS	5391	15391	25391	35391	Ubc IH02 RMS
1359	11359	21359	31359	Ia DC Component	5392	15392	25392	35392	Uca IH02 RMS
1360	11360	21360	31360	Ib DC Component
1361	11361	21361	31361	Ic DC Component	5573	15573	25573	35573	Uab IH63 RMS
1362	11362	21362	31362	I4 DC Component	5574	15574	25574	35574	Ubc IH63 RMS
--	--	--	--	Reserved	5575	15575	25575	35575	Uca IH63 RMS
1364	11364	21364	31364	Ia Fund.	5576	15576	25576	35576	Uab IH00 HD
1365	11365	21365	31365	Ib Fund.	5577	15577	25577	35577	Ubc IH00 HD
1366	11366	21366	31366	Ic Fund.	5578	15578	25578	35578	Uca IH00 HD
1367	11367	21367	31367	I4 Fund.
--	--	--	--	Reserved	5765	15765	25765	35765	Uab IH63 HD
1369	11369	21369	31369	Ia H02 RMS	5766	15766	25766	35766	Ubc IH63 HD
1370	11370	21370	31370	Ib H02 RMS	5767	15767	25767	35767	Uca IH63 HD
1371	11371	21371	31371	Ic H02 RMS	5768	15768	25768	35768	Uab THD
1372	11372	21372	31372	I4 H02 RMS	5769	15769	25769	35769	Ubc THD
--	--	--	--	Reserved	5770	15770	25770	35770	Uca THD
1374	11374	21374	31374	Ia H03 RMS	5771	15771	25771	35771	Uab TOHD
1375	11375	21375	31375	Ib H03 RMS	5772	15772	25772	35772	Ubc TOHD
1376	11376	21376	31376	Ic H03 RMS	5773	15773	25773	35773	Uca TOHD
1377	11377	21377	31377	I4 H03 RMS	5774	15774	25774	35774	Uab TEHD
--	--	--	--	Reserved	5775	15775	25775	35775	Ubc TEHD
...	5776	15776	25776	35776	Uca TEHD
1669	11669	21669	31669	Ia H62 RMS	5777	15777	25777	35777	Uab Angle
1670	11670	21670	31670	Ib H62 RMS	5778	15778	25778	35778	Ubc Angle
1671	11671	21671	31671	Ic H62 RMS	5779	15779	25779	35779	Uca Angle
1672	11672	21672	31672	I4 H62 RMS	5780	15780	25780	35780	Uab Fund. Angle
--	--	--	--	Reserved	5781	15781	25781	35781	Ubc Fund. Angle
1674	11674	21674	31674	Ia H63 RMS	5782	15782	25782	35782	Uca Fund. Angle
1675	11675	21675	31675	Ib H63 RMS
1676	11676	21676	31676	Ic H63 RMS	5966	15966	25966	35966	Uab H63 Angle
1677	11677	21677	31677	I4 H63 RMS	5967	15967	25967	35967	Ubc H63 Angle
--	--	--	--	Reserved	5968	15968	25968	35968	Uca H63 Angle
1679	11679	21679	31679	Pa TH	5969	15969	25969	35969	Uab TIHD
1680	11680	21680	31680	Pb TH	5970	15970	25970	35970	Ubc TIHD
1681	11681	21681	31681	Pc TH	5971	15971	25971	35971	Uca TIHD
1682	11682	21682	31682	Qa TH	5972	15972	25972	35972	Uab TOIHD
1683	11683	21683	31683	Qb TH	5973	15973	25973	35973	Ubc TOIHD
1684	11684	21684	31684	Qc TH	5974	15974	25974	35974	Uca TOIHD
1685	11685	21685	31685	Sa TH	5975	15975	25975	35975	Uab TEIHD
1686	11686	21686	31686	Sb TH	5976	15976	25976	35976	Ubc TEIHD
1687	11687	21687	31687	Sc TH	5977	15977	25977	35977	Uca TEIHD
1688	11688	21688	31688	PFa TH	5978	15978	25978	35978	Uab TH RMS
1689	11689	21689	31689	PFb TH	5979	15979	25979	35979	Ubc TH RMS
1690	11690	21690	31690	PFc TH	5980	15980	25980	35980	Uca TH RMS
1691	11691	21691	31691	Pa TH SUM	5981	15981	25981	35981	Uab TOH RMS
1692	11692	21692	31692	Pb TH SUM	5982	15982	25982	35982	Ubc TOH RMS
1693	11693	21693	31693	Pc TH SUM	5983	15983	25983	35983	Uca TOH RMS
1694	11694	21694	31694	Qa TH SUM	5984	15984	25984	35984	Uab TEH RMS

CET Electric Technology

1695	11695	21695	31695	Qb TH SUM	5985	15985	25985	35985	Ubc TEH RMS
1696	11696	21696	31696	Qc TH SUM	5986	15986	25986	35986	Uca TEH RMS
1697	11697	21697	31697	Sa TH SUM	5987	15987	25987	35987	Uab TIH RMS
1698	11698	21698	31698	Sb TH SUM	5988	15988	25988	35988	Ubc TIH RMS
1699	11699	21699	31699	Sc TH SUM	5989	15989	25989	35989	Uca TIH RMS
1703	11703	21703	31703	Pa TH ABS	5990	15990	25990	35990	Uab TOIH RMS
1704	11704	21704	31704	Pb TH ABS	5991	15991	25991	35991	Ubc TOIH RMS
1705	11705	21705	31705	Pc TH ABS	5992	15992	25992	35992	Uca TOIH RMS
1706	11706	21706	31706	Qa TH ABS	5993	15993	25993	35993	Uab TEIH RMS
1707	11707	21707	31707	Qb TH ABS	5994	15994	25994	35994	Ubc TEIH RMS
1708	11708	21708	31708	Qc TH ABS	5995	15995	25995	35995	Uca TEIH RMS
1709	11709	21709	31709	Sa TH ABS	Reserved
1710	11710	21710	31710	Sb TH ABS	6423	16423	--	--	IR
1711	11711	21711	31711	Sc TH ABS					

All the Flicker, Demand and TC (optional) Parameters are available for SDR, DR and Max./Min Recorders.

Flicker			
ID	Parameter	ID	Parameter
50001	Ua Pst	50004	Ua Plt
50002	Ub Pst	50005	Ub Plt
50003	Uc Pst	50006	Uc Plt
Present Demand			
ID	Parameter	ID	Parameter
51001	Ua DMD	51051	Ubc Over Dev. DMD
51002	Ub DMD	51052	Uca Over Dev. DMD
51003	Uc DMD	51053	Ua Under Dev. DMD
51004	Uln Avg. DMD	51054	Ub Under Dev. DMD
51005	U4 DMD	51055	Uc Under Dev. DMD
51006	Uab DMD	51056	Uab Under Dev. DMD
51007	Ubc DMD	51057	Ubc Under Dev. DMD
51008	Uca DMD	51058	Uca Under Dev. DMD
51009	Ull Avg. DMD	51059	Freq. Dev. DMD
51010	Ia DMD	51060	U0 Unb. DMD
51011	Ib DMD	51061	U2 Unb. DMD
51012	Ic DMD	51062	I0 Unb. DMD
51013	I Avg. DMD	51063	I2 Unb. DMD
51014	I4 DMD	51064	Ia K-Factor DMD
51015	Reserved	51065	Ib K-Factor DMD
51016	Pa Imp. DMD	51066	Ic K-Factor DMD
51017	Pb Imp. DMD	51067	I4 K-Factor DMD
51018	Pc Imp. DMD	51068	Reserved
51019	P Total Imp. DMD	51069	Ua THD DMD
51020	Pa Exp. DMD	51070	Ub THD DMD
51021	Pb Exp. DMD	51071	Uc THD DMD
51022	Pc Exp. DMD	51072	U4 THD DMD
51023	P Total Exp. DMD	51073	Ia THD DMD
51024	Qa Imp. DMD	51074	Ib THD DMD
51025	Qb Imp. DMD	51075	Ic THD DMD
51026	Qc Imp. DMD	51076	I4 THD DMD
51027	Q Total Imp. DMD	51077	Reserved
51028	Qa Exp. DMD	51078	Ua TOHD DMD
51029	Qb Exp. DMD	51079	Ub TOHD DMD
51030	Qc Exp. DMD	51080	Uc TOHD DMD
51031	Q Total Exp. DMD	51081	U4 TOHD DMD
51032	Sa DMD	51082	Ia TOHD DMD
51033	Sb DMD	51083	Ib TOHD DMD
51034	Sc DMD	51084	Ic TOHD DMD
51035	S Total DMD	51085	I4 TOHD DMD
51036	PFa DMD	51086	Reserved
51037	PFb DMD	51087	Ua TEHD
51038	PFc DMD	51088	Ub TEHD
51039	PF Total DMD	51089	Uc TEHD
51040	Freq. DMD	51090	U4 TEHD
51041	Ua Dev. DMD	51091	Ia TEHD
51042	Ub Dev. DMD	51092	Ib TEHD
51043	Uc Dev. DMD	51093	Ic TEHD
51044	Uab Dev. DMD	51094	I4 TEHD
51045	Ubc Dev. DMD	51095	Reserved
51046	Uca Dev. DMD	51096	Ia Fund. DMD
51047	Ua Over Dev. DMD	51097	Ib Fund. DMD
51048	Ub Over Dev. DMD	51098	Ic Fund. DMD

CET Electric Technology

51049	Uc Over Dev. DMD	51099	I4 Fund. DMD
51050	Uab Over Dev. DMD		
Predicted Demand			
ID	Parameter	ID	Parameter
52001	Ua Pred. DMD	52021	Pb Exp. Pred. DMD
52002	Ub Pred. DMD	52022	Pc Exp. Pred. DMD
52003	Uc Pred. DMD	52023	P Total Exp. Pred. DMD
52004	Uln Avg. Pred. DMD	52024	Qa Imp. Pred. DMD
52005	U4 Pred. DMD	52025	Qb Imp. Pred. DMD
52006	Uab Pred. DMD	52026	Qc Imp. Pred. DMD
52007	Ubc Pred. DMD	52027	Q Total Imp. Pred. DMD
52008	Uca Pred. DMD	52028	Qa Exp. Pred. DMD
52009	Ull Avg. Pred. DMD	52029	Qb Exp. Pred. DMD
52010	Ia Pred. DMD	52030	Qc Exp. Pred. DMD
52011	Ib Pred. DMD	52031	Q Total Pred. DMD
52012	Ic Pred. DMD	52032	Sa Pred. DMD
52013	I Avg. Pred. DMD	52033	Sb Pred. DMD
52014	I4 Pred. DMD	52034	Sc Pred. DMD
52015	Reserved	52035	S Total Pred. DMD
52016	Pa Imp. Pred. DMD	52036	PFa Pred. DMD
52017	Pb Imp. Pred. DMD	52037	PFb Pred. DMD
52018	Pc Imp. Pred. DMD	52038	PFc Pred. DMD
52019	P Total Imp. Pred. DMD	52039	PF Total Pred. DMD
52020	Pa Exp. Pred. DMD	52040	Freq. Pred. DMD
This Max. Demand			
ID	Parameter	ID	Parameter
53001	P Total Imp. Max. DMD	53008	Ic Max. DMD
53002	P Total Exp. Max. DMD	53009	Ia Fund. Max. DMD
53003	Q Total Imp. Max. DMD	53010	Ib Fund. Max. DMD
53004	Q Total Exp. Max. DMD	53011	Ic Fund. Max. DMD
53005	S Total Max. DMD	53012	I4 Fund. Max. DMD
53006	Ia Max. DMD	53014	I Avg. Max. DMD
53007	Ib Max. DMD		
Last Max. Demand			
ID	Parameter	ID	Parameter
54001	P Total Imp. Last Max. DMD	54008	Ic Last Max. DMD
54002	P Total Exp. Last Max. DMD	54009	Ia Fund. Last Max. DMD
54003	Q Total Imp. Last Max. DMD	54010	Ib Fund. Last Max. DMD
54004	Q Total Exp. Last Max. DMD	54011	Ic Fund. Last Max. DMD
54005	S Total Last Max. DMD	54012	I4 Fund. Last Max. DMD
54006	Ia Last Max. DMD	54014	I Avg. Last Max. DMD
54007	Ib Last Max. DMD		
TC (optional)			
ID	Parameter	ID	Parameter
56001	TC1	56002	TC2

Appendix B – Device Log Classification

Classification	Sub-Classification	Description	Event Value
1=System	0	Power On	None
	1	Power Off	None
	2	Setup Changes	None
	3	Factory Setup Changes	None
	4	Set Clock	None
	5	Clear All Data	None
	6	Restore Factory Defaults	None
	7	Initialize Device	None
	8	Clear Setup Parameters	None
	9	Clear Factory Setup Parameters	None
	10	Reserved	None
	11	Reserved	None
	12	Clear SDR	See Note 1
	13	Clear DR	See Note 2
	14	Reserved	None
	15	Clear Energy	None
	16	Clear IER Log	None
	17	Clear DI Counter	See Note 3
	18	Clear Flicker Log	BIT0: 0=Pst, 1=Plt
	19	Clear WFR	None
	20	Clear DWR	None
	21	Reserved	
	22	Clear All MM Log	None
	23	Clear Max. Log	See Note 4
	24	Clear Min. Log	See Note 4
	25	Clear Max. Demand	BIT0: 0=This Max. DMD, 1=All Max. DMD
	26	Clear EN 50160 Log	None
	27	Reserved	
	28	Clear PQ Counters	See Note 5
	29	Clear TOU Log	None
	30	Trigger TOU Freeze	None
	31	Reserved	None
	32	Manual Trigger TOU Log	None
	33	Switch TOU Schedule	See Note 6
	34	Hardware Alarm	BIT0: System Parameters Error BIT1: Factory Parameters Error BIT2~BIT6: Reserved BIT7: NVRMA Error BIT8: Memory Error BIT9: DSP Error BIT10: ADC Error
	35	Hardware Normal	None
	36-37	Reserved	
	38	Clear RMS Log	None
	39	Reserved	
	40	Tariff Switch by DI	See Note 7
	41	Tariff Switch by DI Disabled	BIT0~BIT2: T1~T8
	42	Tariff Switch by DI Enabled	None
	43	Uninstall Storage	None
	44-45	Reserved	
	46	Clear Device Log	None
	47	Clear SOE Log	None
	48-49	Reserved	
	50	Clear AER Log	None
	51	Clear All Events	None
	52-58	Reserved	
	59	Clear 2kHz – 150kHz C.E. Report	None
	60	Reserved	
	61	Clear Operating Time	None
	62-63	Reserved	
	64	Clear IEEE Std 519 Log	None
	65	Reset IEEE 519 IL	None
	66	Clear Per-phase AER Log	None

	67	Clear Per-phase IER Log	None
--	----	-------------------------	------

Notes:

1. The bit value "1" for BIT0 to BIT7 of the returned value indicates the SDR Group 1 to 8 is cleared, respectively. The value "0xFFFFFFFF" means all SDRs are cleared.
2. The bit value "1" for BIT0 to BIT7 of the returned value indicates that DR Group 1 to 8 is cleared, respectively. The value "0xFFFFFFFF" means all DR is cleared.
3. The bit value "1" for BIT0 to BIT7 of the returned value indicates that DI Counter 1 to 8 is cleared, respectively. The value "0xFFFFFFFF" means all DI Counters are cleared.
4. The bit value "1" for BIT0 to BIT3 of the returned value indicates the Max./Min. Recorder 1 to 4 is cleared, respectively. The value "0xFFFFFFFF" means all Max./Min. Recorders are cleared.
5. The following table illustrates the detail of the returned value for the Clear PQ Counters event with a bit value of "1" meaning clear.

B0 Dip Counter	B3 Transient Counter	B6 Reserved	B9 MSV #3 Counter
B1 Swell Counter	B4 RVC Counter	B7 MSV #1 Counter	B10 All PQ Counters
B2 Interruption Counter	B5 Inrush Current Counter	B8 MSV #2 Counter	

6. The event value of the Switch TOU Schedule are illustrated in the table below:

Value	Description	Value	Description
1	Switch Schedule 1 to Schedule 2 manually	3	Switch Schedule 1 to Schedule 2 automatically
2	Switch Schedule 2 to Schedule 1 manually	4	Switch Schedule 2 to Schedule 1 automatically

7. The event value of TOU Switch by DI is illustrated in the table below:

Offset	Format	Description
+0	UINT32	Tariff used before TOU Switch
+2	UINT32	Tariff used after TOU Switch

Appendix C – SOE Log Classification

Classification	Sub-Classification	Description	Value
0XA1: PQ Disturbance	0	Voltage Swell	UIN32: Source BIT0: Ua BIT1: Ub, BIT2: Uc BIT3: Uab, BIT4: Ubc, BIT5: Uca FP32: Residual Voltage Max./Min. (%) UIN32: Duration (ms)
	1	Voltage Dip	FP32: Ua Residual (%) FP32: Ub Residual (%) FP32: Uc Residual (%) UIN32: Disturbance Direction Location 1=UpStream, 2=DownStream
	2	Voltage Interruption	UIN32: Confidence 1=Low, 2=Middle, 3=High FP32: Ua Benchmark (Primary) FP32: Ub Benchmark (Primary) FP32: Uc Benchmark (Primary) UIN32: Characteristic Type 0=Residual Voltage
	3	Overvoltage Start	UIN32: Duration (ms) FP32: Ua Residual FP32: Ub Residual
	4	Overvoltage End	FP32: Uc Residual UIN32: Disturbance Direction Location 1=UpStream, 2=DownStream
	5	Undervoltage Start	UIN32: Confidence 1=Low, 2=Middle, 3=High FP32: Ua Benchmark FP32: Ub Benchmark
	6	Undervoltage End	FP32: Uc Benchmark UIN32: Characteristic Type 0=Residual Voltage
0XA2: Transient	0	Voltage Transient	FP32: Disturbance Max./Min. (%) UIN32: Duration (µs) FP32: Ua Disturbance (%) FP32: Ub Disturbance (%) FP32: Uc Disturbance (%)
0XA3: Inrush Current	0	Inrush Current Start	UIN32: Source BIT0: Ua, BIT1: Ub, BIT2: Uc
	1	Inrush Current End	UIN32: Duration (µs) FP32: Ia Max. Disturbance (A) FP32: Ib Max. Disturbance (A) FP32: Ic Max. Disturbance (A) FP32: Ia RMS During Disturbance (A) FP32: Ib RMS During Disturbance (A) FP32: Ic RMS During Disturbance (A)
0XA4: RVC	0	Rapid Voltage Change	UIN32: Start Time (s) UIN32: Start Time (ms) UIN32: Duration (ms) FP32: Max. Voltage Change Rate (%) FP32: Voltage Change Rate (%) UIN32: Source BIT0: Ua, BIT1: Ub, BIT2: Uc BIT3: Uab, BIT4: Ubc, BIT5: Uca
0XA5: MSV	0/2/4	MSV #1/2/3 Start	FP32: Frequency (Hz) UIN32: Source BIT0: Ua, BIT1: Ub, BIT2: Uc BIT3: Uab, BIT4: Ubc, BIT5: Uca
	1/3/5	MSV #1/2/3 End	FP32: Frequency (Hz) FP32: Ua MSV Max. (%) FP32: Ub MSV Max. (%) FP32: Uc MSV Max. (%)
0xA7: Motor Start	0	Motor Start	None
	1	Motor Start End	FP32: Imax FP32: Umin FP32: Duration (ms)

CET Electric Technology

0xA9: Setpoint	0	Over Setpoint Active	UINT32: Parameter (see Table 4-26) FP32: Active Value UINT32: Setpoint Number (0 to 63)
	1	Over Setpoint Return	UINT32: Parameter (see Table 4-26) FP32: Return Value UINT32: Setpoint Number (0 to 63) FP32: Max. Value during Setpoint Active UINT32: Duration (ms)
	128	Under Setpoint Active	UINT32: Parameter (see Table 4-26) FP32: Active Value UINT32: Setpoint Number (0 to 63)
	129	Under Setpoint Return	UINT32: Parameter (see Table 4-26) FP32: Return Value UINT32: Setpoint Number (0 to 63) FP32: Min. Value during Setpoint Active UINT32: Duration (ms)
0xAB: I/O Change	0	Dlx Closed	UINT32: DI Number BIT0 to BIT7 stands for DI1 to DI8
	1	Dlx Open	
	2	DOx Operated	UINT32: DO Number BIT0: Alarm, BIT1 to BIT4 stands for DO1 to DO4 UINT32: Trigger Source 0=DI Change, 1=Setpoint, 2=Reserved, 3=Reserved, 4=Transient, 5=RVC, 6=Inrush Current, 7=Reserved, 8=Remote Control, 9=Pulse Width, 10=Front Panel Control, 11=Reserved, 12=Swell, 13=Dip, 14=Interruption, 15=ITIC Alarm, 16=SEMI F47 Alarm, 17=Motor Start, 18=iTrigger
	3	DOx Released	(Only for Trigger Source = iTrigger) UINT64: iTrigger Source MAC Address (Last 6 ASCII Digits) UINT32: iTrigger Group UINT32: DO Number BIT0: Alarm, BIT1 to BIT4 stands for DO1 to DO4 UINT32: Trigger Source 0=DI Change, 1=Setpoint, 2=Reserved, 3=PQ Disturbance, 4=Transient, 5=RVC, 6=Inrush Current, 7=Reserved, 8=Remote Control, 9=Pulse Width, 10=Front Panel Control, 11=Reserved, 12=Swell, 13=Dip, 14=Interruption
0xAC: Record	0	WFR Triggered	UINT32: Trigger Source 0=Manual, 1=iTrigger, 2=Schedule WFR (Only for Trigger Source = iTrigger) UINT32: iTrigger Group UINT64: iTrigger Source MAC Address (Last 6 ASCII Digits)
	1	DWR Triggered	UINT32: Trigger Source 0=Manual, 1=iTrigger (Only for Trigger Source = iTrigger) UINT64: iTrigger Source MAC Address (Last 6 ASCII Digits)
	2	RMSR Triggered	UINT32: Trigger Source 0=Manual, 1=iTrigger (Only for Trigger Source = iTrigger) UINT32: iTrigger Group UINT64: iTrigger Source MAC Address (Last 6 ASCII Digits)
	3	DRx Start	UINT32: DR Number BIT0 to BIT7 stands for DR1 to DR8 UINT32: Trigger Source 0=DI Change, 1=Setpoint, 2=Reserved, 3=PQ Disturbance, 4=Inrush Current
	4	DRx Stop	UINT32: DR Number BIT0 to BIT7 stands for DR1 to DR8 UINT32: Trigger Source 0=DI Change, 1=Setpoint, 2=Reserved, 3=PQ Disturbance, 4=Inrush Current 5=DI Settings Changed, 6=Setpoint Settings Changed, 7=Reserved, 8=PQ Disturbance Settings Changed, 9=Inrush Current Settings Changed, 10=Stop When Full

Appendix D – Technical Specification

Voltage Inputs (V1, V2, V3, VN, V4, V4N)	
Standard (Un)	400VLN/690VLL+ 20%
Range	5V to 2Un for 400VLN nominal
Overload	2xUn continuous, 4xUn for 1s
Burden	< 0.5VA/per phase
PT Ratio	
Primary	1-1,000,000V
Secondary	1-1,500V
V4 Primary	1-1,000,000V
V4 Secondary	1-1,500V
Frequency	40Hz-60Hz @ 50Hz, 48Hz-72Hz @ 60Hz
Current Inputs (·I11, I12, ·I21, I22, ·I31, I32, ·I41, I42)	
Standard (In)	5A (Standard), 1A (Optional)
Range	1% to 400% In
Starting Current	0.1% In
Overload	4xIn continuous, 10xIn for 1s
Burden	< 0.5VA/per phase @ 5A < 0.1VA/per phase @ 1A
CT Ratio	
Primary	1-30,000A
Secondary	1-50A
I4 Primary	1-30,000A
I4 Secondary	1-50A
SCCP Options	Split-Core Current Probe Input @ max. 500mV
SCCP-50A-500mV	5A/50A (In/Imax), max. 500mV Output
SCCP-200A-200mV	20A/200A (In/Imax), max. 200mV Output
SCCP-500A-500mV	500A Imax, max. 500mV Output
SCCP-5000A-500mV	Selectable 500A/5000A (Imax) Rogowski Coil, max. 500mV Output
SCCT Options	PMC-SCCT-100A-40mA-16-A, Ø=16mm, Class 0.5 PMC-SCCT-200A-40mA-24-A, Ø=24mm, Class 0.5 PMC-SCCT-400A-40mA-35-A, Ø=35mm, Class 0.5 PMC-SCCT-800A-40mA-A, 80x50mm, Class 0.5 PMC-SCCT-1600A-40mA-A, 130x55mm, Class 0.5
SCCTA Option	PMC-SCCT-5A-2mA-16-A, Ø=16mm, Class 1
Power Supply (L/+, N/-)	
Standard	95-250VAC/VDC ± 10%, 47-440 Hz
Optional	20-60VDC
Burden	10W
Overvoltage Category	OVC III 300V
Digital Inputs (DIC, DI1, DI2, DI3, DI4, DIC2, DI5, DI6, DI7, DI8)	
Standard	Dry contact, 24VDC internally wetted
Sampling	1000Hz
Hysteresis	1ms minimum
Digital Outputs (DO11, DO12, DO21, DO22, DO31, DO32, DO41, DO42)	
Type	Form A Mechanical Relay
Loading	5A @ 250VAC/30VDC
Alarm Output (Alarm)	
Loading	5A @ 250VAC or 30VDC
Optional Solid State Pulse Outputs (E1+, E1-, E2+, E2-)	
Type	Form A Solid State Relay
Isolation	Optical
Max. Load Voltage	30VDC
Max. Forward Current	100mA
Optional Analog Inputs (AI1+, AI1-, AI2+, AI2-, SH)	
Type	0-20 / 4-20 mA DC
Overload	24 mA maximum
Optional Temperature Inputs (TC11, TC12, TC21, TC22, SH)	
RTD Type	2-Wire PT100 (sensor not included)
Measurement Range	-40°C to +200°C
Clock Input (CLK+, CLK-, SH)	
Type	GPS, IRIG-B
Accuracy	1ms
Terminals Torque	
Voltage, Current Inputs	Max.: 3.6N·m / 36.7kgf.cm / 31.8lb-in / M4 Tightening: 1N·m / 10kgf.cm / 8.85lb-in / M4
DI, DO, AI, TC, CLK, RS-485,	Max.: 0.39N·m / 4kgf.cm / 3.47lb-in / M2.5

CET Electric Technology

Power Supply	Tightening: 0.25N·m / 2.5kgf.cm / 2.21lb-in / M2.5
Environmental Conditions	
Operating Temp.	-25°C to 70°C
Storage Temp.	-40°C to 85°C
Humidity	5% to 95% non-condensing
Atmospheric Pressure	70 kPa to 110 kPa
Pollution Degree	2
Measurement Category	CAT III 1000V
Mechanical Characteristics	
Panel Cutout	138x138 mm
Unit Dimensions	144x144x128 mm
IP Rating	52

Appendix E – Accuracy Specification

Parameters	Accuracy	Resolution
Voltage (U)	±0.1%	0.001V
I1, I2, I3, I4	5A/1A	±0.1%
	SCCT/SCCTA	±0.1%+Error of SCCT
	SCCPA	±0.1%+Error of SCCP
P, Q, S	5A/1A	±0.2%
	SCCT/SCCTA	±0.5%
	SCCPA	±1%
kWh, kVAh	5A/1A	IEC 62053-22 Class 0.2S
	SCCT/SCCTA	IEC 62053-21 Class 1
	SCCPA	IEC 62053-22 Class 0.5S
kvarh	5A/1A	IEC 62053-24 Class 0.5S IEC 62053-23 Class 2
	SCCT/SCCTA	IEC 62053-24 Class 1 IEC 62053-23 Class 2
	SCCPA	IEC 62053-24 Class 1 IEC 62053-23 Class 2
PF	5A/1A	±0.2%
	SCCT/SCCTA	±0.5%
	SCCPA	±1%
Fundamental Phase Angle	5A/1A	±0.2°
	SCCT/SCCTA	±0.2°+Phase Error of SCCT
	SCCPA	±0.2°+ Phase Error of SCCP
Harmonics Phase Angle	5A/1A	±5°
	SCCT/SCCTA	±5°+Phase Error of SCCT
	SCCPA	±5°+ Phase Error of SCCP
Freq., Freq. Dev.	±0.003Hz	0.001Hz
Harmonics/ Interharmonics	IEC 61000-4-7 Class I	0.01%
U Deviation	±0.1%	0.01%
U Unbalance	±0.1%	0.01%
I Unbalance	±0.5%	0.01%
Pst, Plt	IEC 61000-4-15 Class F1	0.001

Appendix F – Standard Compliance

Safety Requirements	
CE LVD 2014 / 35 / EU	EN 61010-1: 2010 + A1: 2019
cULus Listed	EN IEC 61010-2-030: 2021 + A11: 2021 UL 61010-1, Ed.3, Rev 06/06/2023
CB Test	CAN/CSA-C22.2 No. 61010-1-12, Edition 3, Rev 06/2023 IEC 61010-1: 2010, IEC 61010-1: 2010/AMD1: 2016, IEC 61010-2-030: 2017
Electrical Safety in Low Voltage Distribution Systems up to 1000Vac and 1500 VDC	IEC 61557-12: 2021 (PMD)
Insulation AC Voltage: 2kV @ 1 minute Insulation Resistance: >100MΩ Impulse Voltage: 6kV, 1.2/50μs	IEC 62052-31: 2015 IEC 62053-22: 2003 EN 61010-1: 2010 + A1: 2019
EMC Compatibility	
CE EMC Directive 2014 / 30 / EU (EN IEC 61326-1: 2021 + EN IEC 61326-2-3: 2021) + ICES-003	
Immunity (EN50082-2)	
Electrostatic Discharge	EN 61000-4-2: 2009
Radiated Fields	EN IEC 61000-4-3: 2020
Fast Transients	EN IEC 61000-4-4: 2019
Surges	EN 61000-4-5: 2014 + A1: 2017
Conducted Disturbances	EN 61000-4-6: 2014 + AC: 2015
Magnetic Fields	EN 61000-4-8: 2010
Voltage Dips and Interruptions	EN IEC 61000-4-11: 2020
Ring Wave	EN 61000-4-12: 2017
Immunity Standard for Industrial Environments	EN IEC 61000-6-2: 2019
Emission (EN50081-2)	
Limits and Methods of Measurement of Electromagnetic Disturbance Characteristics of Industrial, Scientific and Medical (ISM) Radio-Frequency Equipment	EN 55011: 2016 + A1: 2017 + A2: 2021
Electromagnetic Compatibility of Multimedia Equipment - Emission Requirements	EN 55032: 2015 + AC: 2016 + A11: 2020
Limits for Harmonic Current Emissions for Equipment with Rated Current ≤16 A	EN IEC 61000-3-2: 2019 + A1: 2021
Limitation of Voltage Fluctuations and Flicker in Low-Voltage Supply Systems for Equipment with Rated Current ≤16 A	EN 61000-3-3: 2013 + AMD1: 2019 IEC 61000-3-3: 2013 + AMD1: 2019
Emission Standard for Industrial Environments	EN IEC 61000-6-4: 2019
Radiated Emissions	FCC 47 CFR Part 15 Subpart B Class B ANSI C63.4: 2014
Conducted Emissions	FCC 47 CFR Part 15 Subpart B Class B ANSI C63.4: 2014
Limits and Methods of Measurement of Radio Frequency Emissions, as well as Administrative Requirements for ITE, including Digital Apparatus.	ICES-003 Issue 7
Mechanical Tests	
Spring Hammer Test	IEC 62052-31: 2015
Vibration Test	IEC 62052-11: 2020
Shock Test	IEC 62052-11: 2020
Power Quality	
Voltage Characteristics of Electricity supplied by Public Distribution Systems	EN 50160: 2022
General Guide on Harmonic and Interharmonic Measurements and Instrumentation, for Power Supply Systems and Equipment Connected Thereto	IEC 61000-4-7: 2009
Flickermeter - Functional and Design Specifications	IEC 61000-4-15: 2010
Testing and Measurement Techniques - Power Quality Measurement Methods	IEC 61000-4-30: 2021 Ed. 3.1 Class A Certified
Power Quality Measurement in Power Supply Systems-Part 2: Functional Tests and Uncertainty Requirements	IEC 62586-2: 2021 Ed. 2.1

Appendix G – Ordering Guide

 Version 20260128	
Product Code	Description
iMeter 7A Advanced Power Quality Analyzer	
Basic Feature	
A	IEC 61000-4-30 Ed. 3.1 Class A Certified with 2kHz-9kHz C.E. Measurements
B*	IEC 61000-4-30 Ed. 3.1 Class A Certified with 2kHz-150kHz C.E. Measurements
Input Current	
5	5A
1	1A
SCCT	For use with 100A/200A/400A/800A/1600A to 40mA SCCTs (SCCTs not included)
SCCTA	For use with 5A/2mA SCCT (SCCTs not included)
SCCPA^	SCCP Option for use with CT Clamps with max. 500mV output (SCCPs not included)
Input Voltage	
9	400VLN/690VLL + 20%
Power Supply	
2	95-250VAC/DC ± 10%, 47-440Hz
3*	20-60VDC
System Frequency	
5	50Hz
6	60Hz
I/O	
A	4xDI + 3xDO
B	4xDI + 1xDO + 2xSS Pulse Output
C*	8xDI + 5xDO + 2xAI
D*	8xDI + 5xDO + 2xRTD Input
Communications	
A	2x100BaseT + 1xRS-485
Display Language	
E	English
iMeter 7A - A 5 9 2 5 A A E	iMeter 7A-A5925AAE (Standard Model)

*Additional charges apply

^ The SCCPA option is compatible with the SCCP models listed in the "SCCP and Accessories" sheet. This option does not come with any Current Clamp. Please refer to the "SCCP and Accessories" sheet for more information and order the desired model and quantity as a separate item.

Contact us

CET Electric Technology Inc.

Email: support@cet-global.com

Web: www.cet-global.com